



## 1.1.1- The Institution ensures effective curriculum delivery through a well-planned and documented process.

List of Supporting Documents Institution & Departmental.

### Institute Level Supporting Documents

- 1) Academic Calendar
- 2) Time Table
- 3) Departmental Staff and Appointments
- 4) Continuous Internal Evaluation (CIE)
- 5) List of Non Working days & Holidays

### Departmental Level Supporting Documents

- 1) Departmental time table
- 2) Workload distribution
- 3) Leave record and adjustments
- 4) Planning for the practical session (science)
- 5) Practical manuals
- 6) Dates for journal submission
- 7) Examination dates
- 8) Question bank
- 9) Question papers
- 10) Activity planning
- 11) Result analysis
- 12) Remedial course planning and execution methodology
- 13) Bridge courses - content, schedule, attendance, material, feedback, feedback analysis.
- 14) Departmental Peer assessment of teaching and its analysis from external Peers.
- 15) Departmental SWOC- External & Internal
- 16) Student feedback on departmental functioning.
- 17) College website-related material uploading - PowerPoint presentations, notes, videos, films, links etc.
- 18) Annual Departmental calendar
- 19) One page of student information and its analysis.
- 20) Departmental meetings.
- 21) Student lists
- 22) Work distribution chart

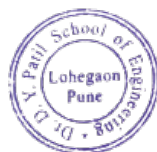

  
Principal  
Dr. F. B. Sayyad

Dr. D. Y. Patil Technical Campus

# Dr. D. Y. Patil School of Engineering

Dr. D. Y. Patil Knowledge City, Charholi (Bk), Lohegaon, Pune – 412 105

1.1.1-The Institution ensures effective curriculum delivery through a well-planned and documented process.

Institution Level List of Supporting Documents

- 1) Academic Calendar
- 2) Time Table
- 3) Departmental Staff and Appointments
- 4) CIE
- 5) List of Non-working days and Holidays.

Dr. D. Y. Patil Technical Campus

# **Dr. D. Y. Patil School of Engineering**

Dr. D. Y. Patil Knowledge City, Charholi (Bk), Lohegaon, Pune – 412 105

## **1. Academic Calendar**



Dr. D. Y. Patil Educational Enterprises Charitable Trust's  
**Dr. D. Y. PATIL SCHOOL OF ENGINEERING**  
 Dr. D. Y. Patil Knowledge City, Charholi (Bk.), Via. Lohgaon, Pune - 412 105

**Term I Academic Calender Academic Year 2020-21**

JULY			AUGUST			SEPTEMBER			OCTOBER			NOVEMBER			DECEMBER		
Date	Day	Activity	Date	Day	Activity	Date	Day	Activity	Date	Day	Activity	Date	Day	Activity	Date	Day	Activity
1	Wed		1	Sat	Bakri Idd	1	Tues	Ananat Chaturdashi	1	Thur		1	Sun		1	Tues	
2	Thur		2	Sun		2	Wed		2	Fri	Mahatma Gandhi Jayanti	2	Mon		2	Wed	
3	Fri		3	Mon	Rakshabandhan	3	Thur		3	Sat		3	Tues		3	Thur	
4	Sat		4	Tues		4	Fri		4	Sun		4	Wed		4	Fri	
5	Sun		5	Wed		5	Sat		5	Mon		5	Thur		5	Sat	
6	Mon		6	Thur		6	Sun		6	Tues	Project Stage Activity-II	6	Fri		6	Sun	
7	Tues		7	Fri		7	Mon		7	Wed		7	Sat		7	Mon	
8	Wed		8	Sat		8	Tues		8	Thur		8	Sun	Unit Test III	8	Tues	
9	Thur		9	Sun		9	Wed		9	Fri	APR II	9	Mon	Project Stage Activity- III	9	Wed	
10	Fri		10	Mon		10	Thur		10	Sat		10	Tues		10	Thur	
11	Sat		11	Tues		11	Fri		11	Sun		11	Wed		11	Fri	
12	Sun		12	Wed		12	Sat		12	Mon		12	Thur	UG Term End as per SPPU	12	Sat	
13	Mon	UG Term Start	13	Thur		13	Sun		13	Tues		13	Fri		13	Sun	
14	Tues		14	Fri		14	Mon	Project Stage Activity- I	14	Wed	Unit Test II	14	Sat	Diwali	14	Mon	
15	Wed		15	Sat	Independence Day	15	Tues		15	Thur	Feed back II	15	Sun		15	Tues	
16	Thur		16	Sun		16	Wed		16	Fri		16	Mon		16	Wed	
17	Fri		17	Mon		17	Thur		17	Sat	Ghatastapna	17	Tues		17	Thur	
18	Sat		18	Tues		18	Fri	APR I	18	Sun		18	Wed		18	Fri	
19	Sun		19	Wed		19	Sat		19	Mon		19	Thur		19	Sat	
20	Mon		20	Thur		20	Sun		20	Tues		20	Fri		20	Sun	
21	Tues		21	Fri	Ganesh Chaturthi	21	Mon		21	Wed		21	Sat		21	Mon	
22	Wed		22	Sat		22	Tues	Unit Test I	22	Thur		22	Sun		22	Tues	
23	Thur		23	Sun		23	Wed	Feed back I	23	Fri		23	Mon	SPPU UG-POE	23	Wed	
24	Fri		24	Mon		24	Thur		24	Sat		24	Tues		24	Thur	
25	Sat		25	Tues		25	Fri		25	Sun		25	Wed		25	Fri	
26	Sun		26	Wed		26	Sat		26	Mon		26	Thur		26	Sat	
27	Mon		27	Thur		27	Sun		27	Tues		27	Fri		27	Sun	
28	Tues		28	Fri		28	Mon		28	Wed		28	Sat		28	Mon	
29	Wed		29	Sat		29	Tues		29	Thur	APR III	29	Sun		29	Tues	
30	Thur		30	Sun		30	Wed		30	Fri	Idd-e-Milad	30	Mon	Guru Nanak Jayanti	30	Wed	
31	Fri		31	Mon					31	Sat					31	Thur	

SPPU Theory Exam / TH Exam

No. of working day=17

No. of working day=23

No. of working day =25

No. of working day =24

No. of working day=06

Total academic working days=95

Holiday

Weekly Off

APR Academic Progress Report

SPPU-POE- SPPU Practical/Oral Examination

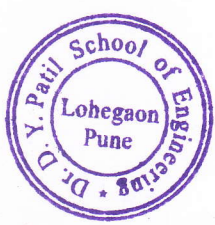

*(Handwritten Signature)*

**Principal**  
 Dr. D. Y. Patil School of Engineering  
 Lohgaon, Pune.



Dr. D. Y. Patil Educational Enterprises Charitable Trust's  
**Dr. D. Y. PATIL SCHOOL OF ENGINEERING**  
 Dr. D. Y. Patil Knowledge City, Charholi (Bk.), Via. Lohgaon, Pune – 412 105

### Academic Calender

Term II												Academic Year 2020-21			
February			March			April			May			June			
Date	Day	Activity	Date	Day	Activity	Date	Day	Activity	Date	Day	Activity	Date	Day	Activity	
1	Mon	UG-Sem Start	1	Mon	APR II	1	Thur	SMADL II	1	Sat	Maharashtra Din	1	Tues		
2	Tues		2	Tues	SMADL I	2	Fri	GoodFriday	2	Sun		2	Wed		
3	Wed		3	Wed		3	Sat		3	Mon	APR VI, FBA II	3	Thur		
4	Thur		4	Thur	Feedback I	4	Sun		4	Tues	SMADL III	4	Fri		
5	Fri		5	Fri		5	Mon		5	Wed	UTMS II	5	Sat	* SPPU Theory Exam Term II / ME-POE & TI Exam (TH Exam UG and PG)	
6	Sat		6	Sat		6	Tues		6	Thur		6	Sun		
7	Sun		7	Sun		7	Wed		7	Fri	UG Term End	7	Mon		
8	Mon		8	Mon		8	Thur		8	Sat		8	Tues		
9	Tues		9	Tues		9 *	Fri		9	Sun		9	Wed		
10	Wed		10	Wed	FBA I	10	Sat		10	Mon		10	Thur		
11	Thur		11	Thur	Mahashivratri	11	Sun		11	Tues		11	Fri		
12	Fri		12	Fri		12	Mon		12	Wed		12	Sat		
13	Sat		13	Sat		13	Tues	Gudipadwa	13	Thur	Ramjan Idd	13	Sun		
14	Sun		14	Sun		14	Wed	Dr.Ambedkar Jayanti	14	Fri		14	Mon		
15	Mon	APR I	15	Mon	APR III	15	Thur		15	Sat		15	Tues		
16	Tues		16	Tues	UTMS I	16	Fri		16	Sun		16	Wed		
17	Wed		17	Wed		17	Sat		17	Mon		17	Thur		
18	Thur		18	Thur		18	Sun		18	Tues		18	Fri		
19	Fri	Shivaji Maharaj Jayanti	19	Fri		19	Mon	APR V	19	Wed		19	Sat		
20	Sat		20	Sat		20	Tues		20	Thur		20	Sun		
21	Sun		21	Sun		21	Wed	Ramnavmi	21	Fri		21	Mon		
22	Mon		22	Mon		22	Thur		22	Sat	* SPPU-POE Practical Exam UG and PG	22	Tues		
23	Tues		23	Tues		23	Fri		23	Sun		23	Wed		
24	Wed		24	Wed		24	Sat		24	Mon		24	Thur		
25	Thur		25	Thur		25	Sun		25	Tues		25	Fri		
26	Fri		26	Fri		26	Mon		26	Wed		26	Sat		
27	Sat		27	Sat		27	Tues		27	Thur		27	Sun		
28	Sun		28	Sun		28	Wed		28	Fri		28	Mon		
			29	Mon	Holi	29	Thur		29	Sat		29	Tues		
			30	Tues	APR IV	30	Fri	Feedback II	30	Sun		30	Wed		
			31	Wed					31	Mon					

No. of working day=24      No. of working day=21      No. of working day =18      No. of working day =05      Total academic working days=68

UTMS- Unit test marks submission      FBA- Feedback analysis  
 APR - Academic Progress Report      UT: Unit Test  
 SMADL- Student monthly attendance & defaulter list      SPPU-POE- SPPU Practical/Oral Examination

Note: \* denotes that mention dates are tentative

*Riyaj*  
 Prof.Riyaj Kazi  
 IQAC -Cordinator

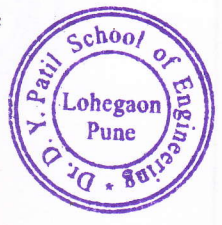

*FB*  
 Dr. F B SAYYAD  
 Principal

Dr. D. Y. Patil Technical Campus

# Dr. D. Y. Patil School of Engineering

Dr. D. Y. Patil Knowledge City, Charholi (Bk), Lohegaon, Pune – 412 105

## 2. Time Table

Dr. D. Y. Patil Educational Enterprises Charitable Trust's Dr. D. Y. PATIL SCHOOL OF ENGINEERING Dr. D. Y. Patil Knowledge City, Charholi (Bk.), Via. Lohgaon, Pune - 412 105															
E&TC Academic Calender															
Term II										Academic Year 2020-21					
February			March			April			May			June			
Date	Day	Activity	Date	Day	Activity	Date	Day	Activity	Date	Day	Activity	Date	Day	Activity	
1	Mon	UG-Sem Start	1	Mon	APR II	1	Thur	SMADL II	1	Sat	Maharashtra Din	1	Tues		
2	Tues		2	Tues	SMADL I	2	Fri	Good Friday	2	Sun		2	Wed		
3	Wed		3	Wed		3	Sat		3	Mon	APR VI, FBA II	3	Thur		
4	Thur		4	Thur	Feedback I	4	Sun		4	Tues	SMADL III	4	Fri		
5	Fri		5	Fri		5	Mon	Alumni Guest lecture	5	Wed	UTMS II	5	Sat		
6	Sat		6	Sat		6	Tues		6	Thur		6	Sun		
7	Sun		7	Sun		7	Wed		7	Fri	UG Term End	7	Mon	* SPPU Theory Exam Term II / ME- POE & TH Exam (TH Exam - UG and PG)	
8	Mon		8	Mon	SE,TE,BE Unit Test I (8 Mar to 11 Mar)	8	Thur	MPSC/UPSC Exam(GL)	8	Sat		8	Tues		
9	Tues		9	Tues		9	Fri	Carrier Guidance (GL)	9	Sun		9	Wed		
10	Wed		10	Wed	FBA I	10	Sat		10	Mon		10	Thur		
11	Thur		11	Thur	Mahashivratri	11	Sun		11	Tues		11	Fri		
12	Fri		12	Fri		12	Mon	Value education (GL)	12	Wed		12	Sat		
13	Sat		13	Sat		13	Tues	Gudipadwa	13	Thur	Ramjan Idd	13	Sun		
14	Sun		14	Sun		14	Wed	Dr. Ambedkar Jayanti	14	Fri		14	Mon		
15	Mon	APR I	15	Mon	APR III	15	Thur		15	Sat		15	Tues		
16	Tues		16	Tues	UTMS I Academic related guest lecture (2 days) guest lecture	16	Fri		16	Sun		16	Wed		
17	Wed		17	Wed		17	Sat		17	Mon		17	Thur		
18	Thur		18	Thur		18	Sun		18	Tues		18	Fri		
19	Fri	Shivaji Maharaj Jayanti	19	Fri		19	Mon	APR V Certificate course-Python Programming for TE BE	19	Wed		19	Sat		
20	Sat		20	Sat		20	Tues		20	Thur		20	Sun		
21	Sun		21	Sun		21	Wed	Rannavuni	21	Fri		21	Mon		
22	Mon		22	Mon		22	Thur		22	Sat		22	Tues		
23	Tues		23	Tues		23	Fri		23	Sun		23	Wed		
24	Wed		24	Wed		24	Sat	Certificate course (end)	24	Mon	* SPPU-POE Practical Exam UG and PG	24	Thur		
25	Thur		25	Thur		25	Sun		25	Tues			25	Fri	
26	Fri		26	Fri		26	Mon	SE,TE,BE Unit Test II (26 April to 30 April)	26	Wed			26	Sat	
27	Sat		27	Sat	Bridge the gap- On recent technology(GL)	27	Tues		27	Thur			27	Sun	
28	Sun		28	Sun		28	Wed		28	Fri			28	Mon	
			29	Mon	Holi	29	Thur		29	Sat			29	Tues	
			30	Tues	APR IV	30	Fri	Feedback II	30	Sun			30	Wed	
			31	Wed					31	Mon					
No. of working day=24			No. of working day=21			No. of working day =18			No. of working day =05			Total academic working days=68			

UTMS- Unit test marks submission  
 APR - Academic Progress Report  
 SMADL- Student monthly attendance & defaulter list  
 Note: \* denotes that mention dates are tentative

FBA- Feedback analysis  
 UT: Unit Test  
 SPPU-POE- SPPU Practical/Oral Examination  
 GL- Guest Lecture

Dr. S. M. Koli  
 HoD (E&TC)

Dr. F B SAYYAD  
 Dean- Academics

Dr. Ashok Kasnale  
 Principal



Dr. D. Y. Patil Technical Campus

# **Dr. D. Y. Patil School of Engineering**

Dr. D. Y. Patil Knowledge City, Charholi (Bk), Lohegaon, Pune – 412 105

## **3. Departmental Staff and Appointments**





"Empowerment through quality technical education"  
Dr D Y Patil Educational Enterprises Charitable Trust's

Ajeenkya D Y Patil Group of Institution's Technical Campus  
**Dr D Y PATIL SCHOOL OF ENGINEERING**

(Approved by AICTE, New Delhi Recognized by Govt. of Maharashtra, Affiliated to Savitribai Phule Pune University)

AISHE Code: C-46648 DTE Code: EN6732 SPPU PUN Code: CEGP015720

(Accredited by NAAC)

A.Y. 2020-21

**Number of Teaching Posts Sanctioned**

(Criteria 2.4.1)

Sanctioned Post As per AICTE--UG						
Sr. No	Department	Intake	Professor	Associate Professor	Assistant Professor	Total Faculty Required
1	Civil	240	1	2	9	12
2	Mech	660	3	6	24	33
3	ETC	240	1	3	8	12
4	Computer	480	2	4	18	24
5	AIDS	60	0	0	3	3
Total		1680	7	15	62	84

Sanctioned Post As per AICTE--PG						
Sr. No	Department	Intake	Professor	Associate Professor	Assistant Professor	Total Faculty Required
1	Mech	48	1	1	1	3
2	ETC	48	1	1	1	3
3	Computer	48	1	1	1	3
Total		144	3	3	3	9

Dr. F. B. Sayyad

Principal





"Empowerment through quality technical education"

Dr D Y Patil Educational Enterprises Charitable Trust's

**Ajeenkya D Y Patil Group of Institution's Technical Campus**

## **Dr D Y PATIL SCHOOL OF ENGINEERING**

(Approved by AICTE, New Delhi Recognized by Govt. of Maharashtra, Affiliated to Savitribai Phule Pune University)

AISHE Code: C-46648 DTE Code: EN6732 SPPU PUN Code: CEGP015720

**(Accredited by NAAC)**

**A.Y. 2020-21**

### **Data of Faculties**

(Criteria 2.2- Program wise list of faculties)

Criteria 2.4.1-Number of full time teachers

Criteria 2.4.3-Teaching experience in the same institute)

<b>Program Name</b>	<b>Number of Teachers</b>
First Year Engg.	09
Civil Engg.	13
Computer Engg.	23
Mechanical Engg.	34
E&TC Engg	13
<b>Total</b>	<b>92</b>

  
**Dr. F. B. Sayyad**

**Principal**

Enclosed: Copy of PAN Cards of Teachers.

# Dr. D Y Patil School of Engineering

Branch wise Staff List AY-2020-21

2.2.2.

2.4.1 Number of full time teachers against sanctioned posts during the year

**2.4.3 Number of years of teaching experience of full time teachers in the same institution (Data for the latest completed academic year- 2020-21)**

Sr. No	Name of the Full-time teacher	PAN	Designation	Year of appointment	Nature of appointment (Against Sanctioned post, temporary, permanent)	Name of the Department	Total years of Experience in the same institution (Total Exp.)	Is the teacher still serving the institution/If not last year of the service of Faculty to the Institution
1	Dr. S. M. Khairnar	AGQPK1277K	Professor & HOD	15.05.2017	Permanent	FE	4	
2	Prof. Rohini Gadgil	BFOPS0517J	Assistant Professor	31.08.2010	Permanent	FE	10	
3	Dr. Shobha Vasant Rupnar	ARPPR1012F	Assistant Professor	06.08.2012	Permanent	FE	8	
4	Prof. Niraj Jadhav	AVSPJ9767G	Assistant Professor	17.12.2012	Permanent	FE	8	23.03.2021
5	Prof. Soma Cyriac	AIGPC6831D	Assistant Professor	10.08.2010	Permanent	FE	10	31.05.2021
6	Dr. Rahulkumar D Katkade	CEVPK1676P	Assistant Professor	10.08.2020	Temporary	FE	8	
7	Prof. Amit Uphad	AIYPU7777J	Assistant Professor	17.12.2020	Temporary	FE	2	10.03.2021
8	Prof. Bhagwat Gidhad	CEZPG6333M	Assistant Professor	01.09.2020	Temporary	FE	2	
9	Prof. Tirupati U Solanke	DKKPS2464F	Assistant Professor	Study Leave	Permanent	FE	6	
10	Lt.col. Sanjay Karodpati	ABXPK0188R	Assistant Professor	04.04.2016	Permanent	Civil	5	
11	Prof. Rajesh Katdare	AGMPK9817F	Assistant Professor	01.06.2015	Permanent	Civil	6	31.05.2021
12	Prof. Ramakant Koshti	AYNPK7736N	Assistant Professor	15.02.2013	Permanent	Civil	9	
13	Prof. Swapnil Bijwe	FBGPS0962H	Assistant Professor	10.08.2020	Temporary	Civil	7.5	
14	Prof. Uday A. Kakde	BKWPK7830F	Assistant Professor	17.08.2020	Temporary	Civil	5.5	
15	Prof. Aakanksha Arun Ingle	AEDPI5052F	Assistant Professor	10.08.2020	Temporary	Civil	3	
16	Prof. Pragya Sharma	GCSPS7201F	Assistant Professor	10.08.2020	Temporary	Civil	2	31.05.2021
17	Prof. Uzma Shaikh	GOGPS6550P	Assistant Professor	11.08.2020	Temporary	Civil	2	
18	Prof. Prasad Rangnath Gayake	BKKPG4681G	Assistant Professor	10.08.2020	Temporary	Civil	1.5	
19	Prof. Aniket Vilas Nemade	AMQPN2843N	Assistant Professor	10.08.2020	Temporary	Civil	1.5	
20	Prof. Ahinsak B Taksande	BARPT6892B	Assistant Professor	01.03.2021	Temporary	Civil	0.5	
21	Prof. Jitendra Dattatray Dalvi	AENPD7780F	Assistant Professor	01.03.2021	Temporary	Civil	7.5	



22	Prof. Aradhana Ganvir	ARTPG4847K	Assistant Professor	14.08.2020	Temporary	Civil	4.5	22.02.2021
23	Dr. Pankaj Agarkar	AEKPA6791G	Assistant Professor	17.01.2014	Permanent	Computer	7	
24	Dr. Sunil Rathod	BPCPR1778C	Assistant Professor	21.01.2014	Permanent	Computer	6	
25	Prof. Pallavi Shimpi	DFYPS9955C	Assistant Professor	22.07.2013	Permanent	Computer	8	
26	Prof. Jayashree Chaudhari	AQIPC3377L	Assistant Professor	08.06.2015	Permanent	Computer	5	
27	Prof. Amruta Chitari	AKBPA4100E	Assistant Professor	24.08.2015	Permanent	Computer	5	
28	Prof. Vandana Chavan	AJCPC7271Q	Assistant Professor	02.06.2017	Permanent	Computer	3	
29	Prof. Yogesh Mali	BZOPM5652C	Assistant Professor	01.06.2017	Permanent	Computer	4	
30	Prof. Chaitanya Bhosale	BBTPB6252L	Assistant Professor	12.06.2017	Permanent	Computer	4	
31	Prof. Ashwini Pandagale	BKCPP6467M	Assistant Professor	01.06.2017	Permanent	Computer	3	
32	Prof. Monika Yograj Dangore	BBOPD3099L	Assistant Professor	10.08.2020	Temporary	Computer	10	
33	Prof. Prashant Prabhakar Sagare	CVKPS4325R	Assistant Professor	17.08.2020	Temporary	Computer	2	31.05.2021
34	Prof. Vishal Kisan Borate	ARKPB6037F	Assistant Professor	10.08.2020	Temporary	Computer	1	
35	Prof. Faraz Aarif Bagwan	CBTPB4731M	Assistant Professor	10.08.2020	Temporary	Computer	2	
36	Prof. Prashant L Mandale	CLKPM4975M	Assistant Professor	10.08.2020	Temporary	Computer	2	
37	Prof. Nilesh Mali	AOOPM7312P	Assistant Professor	10.08.2020	Temporary	Computer	2	
38	Prof. Niyamat Irfan Ujloomwale	ACJPU1531D	Assistant Professor	10.08.2020	Temporary	Computer	1	31.05.2021
39	Prof. Pooja Dinkar Shinde	EXNPS9534K	Assistant Professor	10.08.2020	Temporary	Computer	1	
40	Prof. Ajita Arvind Mahapadi	BZIPM7067D	Assistant Professor	03.07.2017	Temporary	Computer	7.5	
41	Prof. Manali Shimpi	DLJPS1412R	Assistant Professor	10.08.2020	Temporary	Computer	2	
42	Prof. Divyarani P Babar	BZVPB6502K	Assistant Professor	10.08.2020	Temporary	Computer	2	
43	Prof. Rutuja G. Rokade	CCHPR2349A	Assistant Professor	17.08.2020	Temporary	Computer	2	
44	Prof. Rekha S. Kotwal	CFEPK2795F	Assistant Professor	17.08.2020	Temporary	Computer	2	
45	Prof. Girisha Ramhari Bombale	AYKPB3636K	Assistant Professor	20.08.2020	Temporary	Computer	2	
46	Dr. Farook Bashir Sayyad	AYNPS9126L	Professor	15.06.2020	Temporary	Mechanical	2.5	
47	Prof. Rohit Nagesh Garad	ALIPG6426H	Assistant Professor	15.06.2020	Temporary	Mechanical	5	
48	Prof. Amol Baburao Gaikwad	BANPG1908B	Assistant Professor	03.08.2011	Permanent	Mechanical	9	
49	Prof. Sachin S. Jadhav	APRPJ7007G	Assistant Professor	05.07.2012	Permanent	Mechanical	8	
50	Prof. Yogesh S. Gandai	AQDPG1399P	Assistant Professor	09.07.2012	Permanent	Mechanical	8	
51	Dr. Dileep S. More	ATJPM2263P	Assistant Professor	20.07.2015	Permanent	Mechanical	5	
52	Prof. Prashant Gurushantappa Karajagi	AOXPK1159B	Assistant Professor	20.07.2016	Permanent	Mechanical	4	
53	Prof. Santosh Baburao Jadhav	AFCPJ9153L	Assistant Professor	18.03.2015	Permanent	Mechanical	5	



54	Prof. Amol Nanaji Patil	AXPPP3384G	Assistant Professor	16.06.2014	Permanent	Mechanical	6	
55	Prof. Yogesh Shankarrao Danekar	APOPD5502P	Assistant Professor	13.01.2016	Permanent	Mechanical	4	
56	Prof. Ghule Vikram M	ARXPG0889M	Assistant Professor	15.06.2015	Permanent	Mechanical	5	
57	Prof. Parag Bapu Marathe	AYHPM5032F	Assistant Professor	15.01.2016	Permanent	Mechanical	4	
58	Prof. Jagruti C. Nimgulkar	AKXPN2356B	Assistant Professor	12.09.2016	Permanent	Mechanical	4	
59	Prof. Tejaswini Suhas Kulkarni	DNXPK3146J	Assistant Professor	05.06.2017	Permanent	Mechanical	3	
60	Prof. Paresb Pravin Khairnar	DAHPK3946K	Assistant Professor	26.06.2013	Permanent	Mechanical	7	
61	Pooja Nawathe	BFVPM3688C	Assistant Professor	02.06.2017	Permanent	Mechanical	3	
62	Prof. Umaji Kolekar	CORPK1961H	Assistant Professor	27.01.2016	Permanent	Mechanical	4	
63	Prof. Vinod Gopal Patil	BYOPP9441B	Assistant Professor	10.08.2020	Temporary	Mechanical	7	
64	Prof. Sandeep Bhaskar	AUWPB1943M	Assistant Professor	11.08.2020	Temporary	Mechanical	3	
65	Dr. Mohd. Imran Ansari	ANAPA1673Q	Assistant Professor	21.08.2020	Temporary	Mechanical	3	
66	Prof. Nitin More	BBOPM6487K	Assistant Professor	10.08.2020	Temporary	Mechanical	2	
67	Prof. Vinod Deoraaji Tirpude	ADIPT1707G	Assistant Professor	17.08.2020	Temporary	Mechanical	7	
68	Prof. Kunal Shriramprakash Marathe	BGFPM2678J	Assistant Professor	10.08.2020	Temporary	Mechanical	5	
69	Prof. Dipak D. Shelke	DDRPS6298M	Assistant Professor	10.08.2020	Temporary	Mechanical	2	
70	Prof. Amit Shinde	DEUPS5415A	Assistant Professor	10.08.2020	Temporary	Mechanical	6	
71	Prof. Awes Ansari	ARKPA5553F	Assistant Professor	17.08.2020	Temporary	Mechanical	2	
72	Prof. Anil Bavache	CGIPB1141D	Assistant Professor	24.08.2020	Temporary	Mechanical	1	
73	Prof. Kundan Suresh Kolambe	DPMPK7220A	Assistant Professor	25.08.2020	Temporary	Mechanical	1	
74	Prof. Rajabhau Housalmal	AEAPH9760G	Assistant Professor	15.06.2020	Temporary	Mechanical	1.2	
75	Prof. Avinash.R.Kulkarni	AMBPK7578C	Assistant Professor	10.08.2020	Temporary	Mechanical	1.2	
76	Prof. Santosh R. Thorat	ALRPT2853L	Assistant Professor	10.08.2020	Temporary	Mechanical	1.2	
77	Prof. Mayuri Sanjay Mhaske	BKWPM3206R	Assistant Professor	17.08.2020	Temporary	Mechanical	1.2	
78	Prof. Meghasham Jagadish joshi	AKOPJ7912N	Assistant Professor	21.08.2020	Temporary	Mechanical	1.2	
79	Prof. Himani Kadam	ALKPK5188L	Assistant Professor	10.08.2020	Temporary	Mechanical	3	22.01.2021
80	Dr. Sanjay Koli	ALSPK7778A	HOD & Professor	19.07.2016	Permanent	E&TC	4	
81	Dr. Rashmi Mahajan	AMHPP2562P	Assistant Professor	18.07.2011	Permanent	E&TC	9	
82	Prof. Riyaj L. Kazi	ARVPM8357J	Assistant Professor	01.07.2013	Permanent	E&TC	7	
83	Dr. Bahubali Shirgarpur	BGNPS5767E	Assistant Professor	02.08.2011	Permanent	E&TC	9	29.07.2020
84	Prof. Kundankumar Saraf	CPYPS1104N	Assistant Professor	23.07.2015	Permanent	E&TC	5	20.07.2020



85	Prof. Swati Khawate	BMMPK6304E	Assistant Professor	22.06.2013	Permanent	E&TC	7	
86	Prof. Nishikant B Surwade	CEBPS6783M	Assistant Professor	01.04.2014	Permanent	E&TC	6	
87	Prof. Prajakta Khairnar	AWAPG7877P	Assistant Professor	01.06.2015	Permanent	E&TC	5	
88	Dr. Saniya Ansari	AJQPG2834D	Associate Professor	15.06.2020	Temporary	E&TC	8	
89	Prof. Gaurav Tiwari	ASLPT2103Q	Assistant Professor	10.08.2020	Temporary	E&TC	3	31.05.2021
90	Prof. Sayali Sanket Mane	CDCPM8976J	Assistant Professor	14.08.2020	Temporary	E&TC	2	
91	Prof. Ashwini Adeshkumar Bagade	ESVPS4216P	Assistant Professor	10.08.2020	Temporary	E&TC	2	
92	Prof. Yogesh Y. Shinde	BNIPS2444G	Assistant Professor	10.08.2020	Temporary	E&TC	3	14.12.2020

Total Exp 401.5  
Average Exp 4.364130435

*(Handwritten Signature)*

**Principal**  
Dr. D. Y. Patil School of Engineering  
Lohegaon, Pune.





"Empowerment through quality technical education"  
Dr. D. Y. Patil Educational Enterprises Charitable Trust's

Ajeenkya D Y Patil Group of Institution's Technical Campus  
**Dr D Y PATIL SCHOOL OF ENGINEERING**

(Approved by AICTE, New Delhi Recognized by Govt. of Maharashtra, Affiliated to Savitribai Phule Pune University)  
AISHE Code: C-46648 DTE Code: EN6732 SPPU PUN Code: CEGP015720  
(Accredited by NAAC)

**A.Y. 2020-21**

**Appointment Letters of Teachers**

(Criteria 2.4.1)

Program Name	Number of Teachers
Computer Engg.	23
Mechanical Engg.	34
Civil Engg.	13
E&TC Engg	13
First Year Engg.	09
<b>Total</b>	<b>92</b>

**Dr. F. B. Sayyad**  
Principal



**Enclosed:** Appointment orders of Teachers.



**D Y PATIL GROUP**

DR D Y PATIL GROUP OF INSTITUTION'S  
DR D Y PATIL TECHNICAL CAMPUS

**Dr D Y PATIL SCHOOL OF ENGINEERING**

No.DrDYP SOE/AO/ANC/09082015

Date: 09/08/2015

**APPOINTMENT ORDER**

To:

Ms Amruta Nagesh Chitari

**E Mail:** amrutachitari@gmail.com

**Mobile:** +91 9850839362

Sub: Appointment to the Post of Assistant Professor in Department of Computer Engineering at Dr D Y Patil School of Engineering, Pune

Madam,

With reference to the subject mentioned above, we have pleasure to inform you that you are appointed as **Assistant Professor** in **Department of Computer Engineering** at Dr D Y Patil School of Engineering at Dr D Y Patil Knowledge City, Charholi Bk., Via Lohegaon, Pune 412 105. This appointment is subject to the following terms and conditions:

- 1) The appointment will be effective from the date of your joining the duties.
- 2) The appointment is on temporary ad-hoc basis. You will have to apply and appear for interview before a Selection Committee constituted as per norms of Pune University as and when the posts are advertised, for regularization of your appointment. The continuation of your appointment is subject to your performance, recommendations and decision of this committee.
- 3) You will be paid a monthly remuneration which includes basic pay of Rs 15600 (Rs Fifteen Thousand Six Hundred Only) plus Academic Grade Pay (AGP) of Rs. 6,000 (Rs Six Thousand) in Sixth Pay Commission Pay Band of Rs 15,600 - 39100 and other allowances as prescribed by the Trust from time to time. The salary payments will be subject to deduction of statutory taxes as applicable.
- 4) You will have to perform duties as mentioned below
  - a) To teach the subject/s assigned to you by the Principal/Director of the School (Theory as well as Practical) in accordance with the syllabus of the University.
  - b) To carry out any other duties as may be assigned to you from time to time by the Principal/Director of the School for smooth conduct of academic and allied co-curricular programmes and conduct of various institute and university examinations including assessment of papers.
  - c) To participate in various skill development /reorientation / training programmes aimed at upgrading teaching capabilities of teaching faculty.

*Chitani*  
8/8/2015

*Received*  
*G. Patil*  
31/9/15



- 5) For discharge of your duties you will be responsible to the Principal/ Director of the School of Engineering and subject the rules and regulations as laid down by the University, AICTE and State Government & Trust.
- 6) While joining the duties, you will have to submit two sets of certified true copies of documents in support of your qualifications, experience, discharge certificate from previous employer and three recent passport size photographs and execute an agreement as prescribed by the Trust.
- 7) You will be required to undergo medical examination before Medical Officer attached to the Dr D Y Patil Knowledge City Campus when medical check up of staff of the Institutions in the Dr D Y Patil Knowledge City Campus is organized.
- 8) You will have to submit your correct mailing address on joining the duties and also keep the Director of the School informed about subsequent changes, if there be any. The communication sent by the institute by RPAD on the address given by you shall be deemed to have been received and acknowledged by you.
- 9) You will not conduct or engage yourself in any private tuitions or private coaching classes., will not engage yourself in any other job, paid or honorary, full time or part time while in the service of the this institute.
- 10) Your services are transferable to any other institute run by D Y Patil Group.
- 11) You will have to give three months' notice or pay/forgo three month's salary in lieu of the notice period while resigning the job. It is desirable that being a teaching faculty, you do not leave the job when the teaching session is in progress.
- 12) a) If it is observed that your performance is not satisfactory /your behavior is not in the interest of the institute/trust/ you commit breach of the terms and conditions governing your appointment/you are found medically unfit (physically/mentally), your services shall be terminated without giving any notice period.  
b) Your continuous unauthorized absence from duty for more than fifteen days shall lead to automatic termination of your services from the date from which you remain absent.  
c) If you are not selected and recommended for regularization by the Selection Committee constituted as per norms of the University, your services shall terminated with effect from the date on which the candidate selected by the said committee reports for duty.

Yours faithfully,

**For Dr D Y Patil School of Engineering**



**Prof B G Bhandarkar**  
**Director Corporate Relations**  
**Authorised Signatory**

Copy to

1. Principal/Director Dr D Y Patil School of Engineering  
[2 copies 1. Personal File 2. Accounts Section]
2. Chief Financial Officer Head Office
3. DYPEECT Master File



DR D Y PATIL GROUP OF INSTITUTION'S  
DR D Y PATIL TECHNICAL CAMPUS

## Dr D Y PATIL SCHOOL OF ENGINEERING

No. DrDYPSOE/AL/JIC/01062015

Date: 01/06/2015

### APPOINTMENT ORDER

To:

**Ms Jayshree I Chaudhari**

E Mail: cjayu@rediffmail.com

Mobile: +91 9987528693

Sub: Appointment to the Post of Assistant Professor, Department of Computer Engineering at Dr D Y Patil School of Engineering, Pune

Madam,

With reference to the subject mentioned above, we have pleasure to inform you that you are appointed as **Assistant Professor, Department of Computer Engineering** at Dr D Y Patil School of Engineering, Dr D Y Patil Knowledge City, Charholi Bk., Via Lohegaon, Pune 412 105. This appointment is subject to the following terms and conditions :

- 1) The appointment will be effective from the date of your joining the duties.
- 2) The appointment is on temporary ad-hoc basis. You will have to apply and appear for interview before a Selection Committee constituted as per norms of Pune University as and when the posts are advertised, for regularization of your appointment. The continuation of your appointment is subject to your performance, recommendations and decision of this committee.
- 3) You will be paid a monthly remuneration which includes basic pay of Rs 19500 (Rs Nineteen Thousand Five hundred only) plus Academic Grade Pay (AGP) of Rs. 6,000 (Rs Six Thousand) in Sixth Pay Commission Pay Band of Rs 15,600 - 39100 plus personal pay of Rs 5000 (Rs Five Thousand) and other allowances as prescribed by the Trust from time to time. The personal pay will be suitably adjusted in the event of increase in DA. The salary payments will be subject to deduction of statutory taxes as applicable.
- 4) You will have to perform duties as mentioned below:
  - a) To teach the subject/s assigned to you by the Principal/Director of the School (Theory as well as Practical) in accordance with the syllabus of the University.
  - b) To carry out any other duties as may be assigned to you from time to time by the Principal/Director of the School for smooth conduct of academic and allied co-curricular programmes and conduct of various institute and university examinations including assessment of papers.
  - c) To participate in various skill development /reorientation/ training programmes aimed at upgrading teaching capabilities of teaching faculty.
- 5) For discharge of your duties you will be responsible to the Principal/ Director of the School of Engineering and subject the rules and regulations as laid down by the University, AICTE and State Government & Trust.

Received  
Gnpatil  
17/06/15

Recd.  
Shankh

- 6) While joining the duties, you will have to submit two sets of certified true copies of documents in support of your qualifications, experience, discharge certificate from previous employer and three recent passport size photographs and execute an agreement as prescribed by the Trust.
- 7) You will be required to undergo medical examination before Medical Officer attached to the Dr D Y Patil Knowledge City Campus when medical check up of staff of the Institutions in the Dr D Y Patil Knowledge City Campus is organized.
- 8) You will have to submit your correct mailing address on joining the duties and also keep the Director of the School informed about subsequent changes, if there be any. The communication sent by the institute by RPAD on the address given by you shall be deemed to have been received and acknowledged by you.
- 9) You will not conduct or engage yourself in any private tuitions or private coaching classes., will not engage yourself in any other job, paid or honorary, full time or part time while in the service of the this institute.
- 10) Your services are transferable to any other institute run by D Y Patil Group.
- 11) You will have to give three months' notice or pay/forgo three month's salary in lieu of the notice period while resigning the job. It is desirable that being a teaching faculty, you do not leave the job when the teaching session is in progress.
- 12) a) If it is observed that your performance is not satisfactory /your behavior is not in the interest of the institute/trust/ you commit breach of the terms and conditions governing your appointment/you are found medically unfit (physically/mentally), your services shall be terminated without giving any notice period.  
b) Your continuous unauthorized absence from duty for more than fifteen days shall lead to automatic termination of your services from the date from which you remain absent.  
c) If you are not selected and recommended for regularization by the Selection Committee constituted as per norms of the University, your services shall terminated with effect from the date on which the candidate selected by the said committee reports for duty.

**Yours faithfully,  
For Dr D Y Patil School of Engineering**

  
**Prof B G Bhandarkar  
Director Corporate Relations  
Authorised Signatory**

Copy to

1. Principal/Director Dr D Y Patil School of Engineering  
[2 copies 1. Personal File 2. Accounts Section]
2. Chief Financial Officer Head Office
3. DYPEECT Master File

*Handwritten notes and stamps:*  
Received  
11/11/2011  
Dr. D. Y. Patil  
Knowledge City Campus



**Dr D Y PATIL EDUCATIONAL ENTERPRISES CHARITABLE TRUST**

No.DrDYPEECT/IC/APP/SoE/14-001

Date : 6.1.2014

**APPOINTMENT ORDER**

To:

**MrSunil Rathod**

E Mail : sunil2k\_r@yahoo.co.in

Mobile : +91 97665 82199

**Sub : Appointment to the Post of Asstt Prof of Computer Engineering  
at Dr.D.Y.Patil School of Engineering , Pune**

Sir ,

With reference to the subject mentioned above, we have pleasure to inform you that you are appointed as **Asstt. Professor of Computer Engineering** at Dr.D.Y.Patil School of Engineering at Dr.D.Y.Patil Knowledge City, Charholi Bk.,Via Lohegaon, Pune 412 105.This appointment is subject to the following terms and conditions :

- 1) The appointment will be effective from the date of your joining the duties .
- 2) The appointment is on temporary ad-hoc basis .You will have to apply and appear for interview before a Selection Committee constituted as per norms of Pune University as and when the posts are advertised, for regularization of your appointment. The continuation of your appointment is subject to your performance , recommendations and decision of this committee.
- 3) You will be paid pay of Rs 29250/- ( Rs.Twenty nine thousand two hundred & fifty only ) plus Academic Grade Pay (AGP) of Rs. 6000/- ( Rs. Six thousand only ) per month in Sixth Pay Commission Pay Band of Rs.15600-39100 and other allowances as prescribed by the Trust from time to time.,plus personal special pay of Rs.10,000/- (Rs.Ten thousand only )The salary payments will be subject to deduction of statutory taxes as applicable.
- 4) You will have to perform duties as mentioned below
  - a) To teach the subject/s assigned to you by the Principal/Director of the School (Theory as well as Practicals ) in accordance with the syllabus of the University.
  - b) To carry out any other duties as may be assigned to you from time to time by the Principal/Director of the School for smooth conduct of academic and allied co-curricular programmes and conduct of various institute and university examinations including assessment of papers.
  - c) To participate in various skill development /reorientation / training programmes aimed at upgrading teaching capabilities of teaching faculty.
- 5) For discharge of your duties you will be responsible to the Principal/ Director of the School of Engineering and subject the rules and regulations as laid down by the University, AICTE and State Government & Trust .
- 6) While joining the duties, you will have to submit two sets of certified true copies of documents in support of your qualifications , experience, discharge certificate from previous employer and three recent passport size photographs and execute an agreement as prescribed by the Trust..

*Received*  
*Sunil Rathod*  
*21/01/2014*

*Received by*  
*[Signature]*

- 7) You will be required to undergo medical examination before Medical Officer attached to the .Dr.D.Y.Patil Knowledge City Campus when medical check up of staff of the Institutions in the Dr.D.Y.Patil Knowledge City Campus is organized .
- 8) You will have to submit your correct mailing address on joining he duties and also keep the Director of the School informed about subsequent changes, if there be any. The communication sent by the institute by RPAD on the address given by you shall be deemed to have been received and acknowledged by you.
- 9) You will not conduct or engage yourself in any private tuitions or private coaching classes., will not engage yourself in any other job, paid or honorary, full time or part time while in the service of the this institute.
- 10) Your services are transferable to any other institute run by D.Y.Patil Group.
- 11) You will have to give one month's notice or pay/forgo one month's salary in lieu of the notice period while resigning the job.It is desirable that being a teaching faculty , you do not leave the job when the teaching session is in progress.
- 12) a) If it is observed that your performance is not satisfactory /your behaviour is not in the interest of the institute/trust/ you commit breach of the terms and conditions governing your appointment/you are found medically unfit (physically/mentally) ,your services shall be terminated without giving any notice period.  
b) Your continuous unauthorized absence from duty for more than fifteen days shall lead to automatic termination of your services from the date from which you remain absent.  
c) If you are not selected and recommended for regularization by the Selection Committee constituted as per norms of the University, your services shall terminated with effect from the date on which the candidate selected by the said committee reports for duty.

Yours faithfully,

**For Dr.D.Y.Patil Educational Enterprises Charitable Trust**

  
**Prof.B.G.Bhandarkar**  
**Director Corporate Relations**  
**Authorised Signatory**

Copy to

- 1 Principal/Director Dr.D.Y.Patil School of Engineering  
[ 2 copies ✓ 1 .Personal File 2.Accounts Section ]
- 2 Chief Financial Officer Head office
- 3 DYPEECT Master File

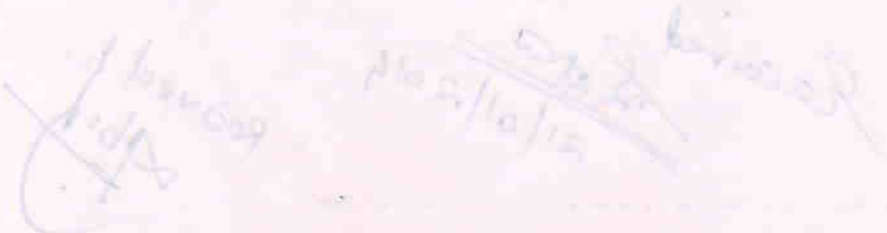
  
11/05/12



D Y PATIL GROUP

**Dr D Y PATIL EDUCATIONAL ENTERPRISES CHARITABLE TRUST**

No.DrDYPEECT/IC/APP/SoE/ 13-056

Date : . 17.6.2013

**APPOINTMENT ORDER**

To:

Ms.Pallavi Madhukar Shimpi

E Mail : pallavi\_shimpi27@rediffmail.com

Mobile : +91 87938 79353

Sub : Appointment to the Post of **Lecturer in Computer Engineering**  
at Dr.D.Y.Patil School of Engineering Pune

Madam,

With reference to the subject mentioned above, we have pleasure to inform you that you are appointed as **Lecturer in Computer Engineering** at Dr.D.Y.Patil School of Engineering at Dr.D.Y.Patil Knowledge City, Charholi Bk.,Via Lohegaon, Pune 412 105.This appointment is subject to the following terms and conditions :

- 1) The appointment will be effective from the date of your joining the duties .
- 2) The appointment is on temporary ad-hoc basis .You will have to apply and appear for interview before a Selection Committee constituted as per norms of Pune University as and when the posts are advertised, for regularization of your appointment. The continuation of your appointment is subject to your performance , recommendations and decision of this committee.
- 3) You will be paid basic salary of Rs.8,825/- (Rs.Eight thousand eight hundred & twenty five only ) in the pay scale of Rs.8000-275-13500 and other allowances as prescribed by the Trust from time to time.. The salary payments will be subject to deduction of statutory taxes as applicable
- 4) You will have to perform duties as mentioned below
  - a) To teach the subject/s assigned to you by the Principal/ Director of the School (Theory as well as Practicals ) in accordance with the syllabus of the University.
  - b) To carry out any other duties as may be assigned to you from time to time by the Principal/Director of the School for smooth conduct of academic and allied co-curricular programmes and conduct of various institute and university examinations including assessment of papers.
  - c) To participate in various skill development /reorientation / training programmes aimed at upgrading teaching capabilities of teaching faculty.
- 5) For discharge of your duties you will be responsible to the Principal/ Director of the School of Engineering and subject the rules and regulations as laid down by the University, AICTE , State Government and the Trust.
- 6) While joining the duties, you will have to submit two sets of certified true copies of documents in support of your qualifications , experience, discharge certificate from previous employer and three recent passport size photographs and execute an agreement as prescribed by the Trust..

Received.

Pallavi  
22/7/13

Received  
29/7/13

- 7) You will be required to undergo medical examination before Medical Officer attached to the Dr.D.Y.Patil Knowledge City when medical check up of staff of the Institutions under Dr.D.Y.Patil Knowledge City Campus is organized .
- 8) You will have to submit your correct mailing address on joining he duties and also keep the Principal/ Director of the School informed about subsequent changes, if there be any. The communication sent by the institute by RPAD on the address given by you shall be deemed to have been received and acknowledged by you.
- 9) You will not conduct or engage yourself in any private tuitions or private coaching classes., will not engage yourself in any other job, paid or honorary, full time or part time while in the service of the this institute.
- 10) Your services are transferable to any other institute run by D.Y.Patil Group.
- 11) You will have to give one month's notice or pay/forgo one month's salary in lieu of the notice period while resigning the job.It is desirable that being a teaching faculty , you do not leave the job when the teaching session is in progress.
- 12) a) If it is observed that your performance is not satisfactory /your behaviour is not in the interest of the institute/trust/ you commit breach of the terms and conditions governing your appointment/you are found medically unfit (physically/mentally) ,your services shall be terminated without giving any notice period.  
b) Your continuous unauthorized absence from duty for more than fifteen days shall lead to automatic termination of your services from the date from which you remain absent.  
c) If you are not selected and recommended for regularization by the Selection Committee constituted as per norms of the University, your services shall terminated with effect from the date on which the candidate selected by the said committee reports for duty.

Yours faithfully,

For Dr.D.Y.Patil Educational Enterprises Charitable Trust

Prof.B.G.Bhandarkar  
Director Corporate Relations  
Authorised Signatory

Copy to

- 1 Principal/Director Dr.D.Y.Patil School of Engineering  
[ 2 copies ✓ 1 .Personal File 2.Accounts Section ]
- 2 Chief Financial Officer Head office
- 3 DYPEECT Master File



DR. D. Y. PATIL GROUP

**Dr D Y PATIL EDUCATIONAL ENTERPRISES CHARITABLE TRUST**

No.DrDYPEECT/IC/APP/SoE/14-004

Date : 6.1.2014

**APPOINTMENT ORDER**

To:

**Mr.Pankaj Agarkar**

E Mail : pmagarkar@rediffmail.com

Mobile : +91 98235 35491

**Sub : Appointment to the Post of Asstt Prof of Computer Engineering  
at Dr.D.Y.Patil School of Engineering , Pune**

Sir ,

With reference to the subject mentioned above, we have pleasure to inform you that you are appointed as **Asstt. Professor of Computer Engineering** at Dr.D.Y.Patil School of Engineering at Dr.D.Y.Patil Knowledge City, Charholi Bk.,Via Lohegaon, Pune 412 105.This appointment is subject to the following terms and conditions :

- 1) The appointment will be effective from the date of your joining the duties .
- 2) The appointment is on temporary ad-hoc basis .You will have to apply and appear for interview before a Selection Committee constituted as per norms of Pune University as and when the posts are advertised, for regularization of your appointment. The continuation of your appointment is subject to your performance , recommendations and decision of this committee.
- 3) You will be paid pay of Rs 29250/- ( RsTwenty nine thousand two hundred & fifty only ) plus Academic Grade Pay (AGP) of Rs. 6000/- ( Rs. Six thousand only ) per month in Sixth Pay Commission Pay Band of Rs.15600-39100 and other allowances as prescribed by the Trust from time to time plus special pay of Rs.10,000/- ( Rs.Ten thousand only ) pm .The salary payments will be subject to deduction of statutory taxes as applicable.
- 4) You will have to perform duties as mentioned below
  - a) To teach the subject/s assigned to you by the Principal/Director of the School (Theory as well as Practicals ) in accordance with the syllabus of the University.
  - b) To carry out any other duties as may be assigned to you from time to time by the Principal/Director of the School for smooth conduct of academic and allied co-curricular programmes and conduct of various institute and university examinations including assessment of papers.
  - c) To participate in various skill development /reorientation / training programmes aimed at upgrading teaching capabilities of teaching faculty.
- 5) For discharge of your duties you will be responsible to the Principal/ Director of the School of Engineering and subject the rules and regulations as laid down by the University, AICTE and State Government & Trust .
- 6) While joining the duties, you will have to submit two sets of certified true copies of documents in support of your qualifications , experience, discharge certificate from previous employer and three recent passport size photographs and execute an agreement as prescribed by the Trust..



- 7) You will be required to undergo medical examination before Medical Officer attached to the .Dr.D.Y.Patil Knowledge City Campus when medical check up of staff of the Institutions in the Dr.D.Y.Patil Knowledge City Campus is organized .
- 8) You will have to submit your correct mailing address on joining he duties and also keep the Director of the School informed about subsequent changes, if there be any. The communication sent by the institute by RPAD on the address given by you shall be deemed to have been received and acknowledged by you.
- 9) You will not conduct or engage yourself in any private tuitions or private coaching classes., will not engage yourself in any other job, paid or honorary, full time or part time while in the service of the this institute.
- 10) Your services are transferable to any other institute run by D.Y.Patil Group.
- 11) You will have to give one month's notice or pay/forgo one month's salary in lieu of the notice period while resigning the job.It is desirable that being a teaching faculty , you do not leave the job when the teaching session is in progress.
- 12) a) If it is observed that your performance is not satisfactory /your behaviour is not in the interest of the institute/trust/ you commit breach of the terms and conditions governing your appointment/you are found medically unfit (physically/mentally) ,your services shall be terminated without giving any notice period.  
b) Your continuous unauthorized absence from duty for more than fifteen days shall lead to automatic termination of your services from the date from which you remain absent.  
c) If you are not selected and recommended for regularization by the Selection Committee constituted as per norms of the University, your services shall terminated with effect from the date on which the candidate selected by the said committee reports for duty.

Yours faithfully,

**For Dr.D.Y.Patil Educational Enterprises Charitable Trust**

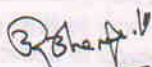
  
**Prof.B.G.Bhandarkar**  
**Director Corporate Relations**  
**Authorised Signatory**

Copy to

- Principal/Director Dr.D.Y.Patil School of Engineering  
[ 2 copies  Personal File 2.Accounts Section ]
- 2 Chief Financial Officer Head office
- 3 DYPECT Master File



D Y PATIL GROUP

## Dr D Y PATIL EDUCATIONAL ENTERPRISES CHARITABLE TRUST

No.DrDYPEECT /DYPSOE/US/APP/2017/586-32

Date: 08.05.2017

### APPOINTMENT ORDER

To,  
Mr. Mali Yogesh Kisan  
A-21 shivam flora sangali  
Vishram baugh, Pune

**Subject:** Appointment to the Post of **Assistant Professor in Computer Engg** at **Dr. D Y Patil School of Engineering**.

Sir,

With reference to your application for the post of **Assistant Professor in Computer Engg**, in response to advertisement on 6<sup>th</sup> Februarys, 2017 in Indian Express and Loksatta and subsequent interview on 26<sup>th</sup> March, 2017 before Selection Committee constituted by Savitribai Phule Pune University. We have pleasure in informing you that you are selected by the committee and appointed as **Assistant Professor in Computer Engg** at Dr. D Y Patil School of Engineering, Dr. D. Y. Patil Knowledge City, Charholi Bk, Via Lohegaon, Pune 412 105. The Appointment is subject to the following terms & conditions;

1. This appointment is effective from the date of your joining the duties. You will have to join the duties within **15 days** from the date of this appointment order *i.e.* **by 15<sup>th</sup> May, 2017**. In the event you do not join the duties within this time limit it will be assumed that you do not intend to join the duties and the appointment order issued in your favour will stand automatically cancelled.

However in case you need an extension of time limit for joining the duties you will have to apply in writing for grant of extension stating the reasons for the same and indicating the date on which you intend to join the duties. The request for grant of extension of time limit for joining the duties of the post shall be considered and you will be informed in the matter. The decision of the management of the Dr. D Y Patil School of Engineering shall be final.

2. You will be governed by the Maharashtra Universities Act , statues, ordinances, rules & regulations , code of conduct, laid down by the Savitribai Phule Pune University, Government of Maharashtra and service rules of the Trust and will be responsible to the Director of the Institute for discharge of your duties.

3. The post is for **OBC** category and since you belong to **OBC** category you are appointed in clear vacancy on fulltime basis and you will be on probation for a period of two years from the date of joining the duties subject to approval by Savitribai Phule Pune University. The continuation beyond probation period will be subject to your satisfactory completion of probation.

4. You will be paid basic salary of **Rs. 16250/-** (in words Rs. Sixteen Thousand Two Hundred Fifty Only) plus Academic Grade Pay of **Rs. 06,000/-** (Rs. Six Thousand Only) per month in the pay scale of **Rs. 15600-39100**.

The Salary payment will be subject to deduction of statutory taxes as applicable.

[PTO]

Received  
Shri  
19/7/17

5. You will have to perform duties as mentioned below:

- a) To teach the subject/s assigned to you by the Head of Department/ Institute (theory as well as practicals) in accordance with syllabus of the Savitribai Phule Pune University.
- b) To carry out any other duties as may be assigned to you from time to time by the Head of Department / Institute for smooth conduct of academic and allied co-curricular activities as well as conduct of various institute level and university examinations.
- c) To participate in various skill development / reorientation / training programmes.

6. You shall undergo medical examination before Medical Officer attached with Dr. D Y Patil Knowledge City within three months from the date of joining the duties. The appointment shall be provisional and conditional, pending submission of Medical Certificate stating that you are free from any contagious disease and you are physically fit for employment as the staff of the Institute.

7. You will not engage yourself in any private tuitions or private coaching classes, will not engage yourself in any other job, paid or honorary, full time or part time, while in the service of the institute. You will not undertake any R & D or consultancy work and not register for any degree / diploma / certificate course without approval of the competent authority of the Trust.

8. While joining the duties you will have to submit a) Last Pay Slip from the previous Employer b) Two recent pass-post size photographs c) Two copies of the certificates in support of your qualifications & experience.

9. You will have to submit your correct mailing address while joining the duties and also inform in writing to the Head of the Institute about subsequent changes, if there be any. The communication sent by RPAD on the address given by you shall be deemed to have been received by you.

10. You will have to give one months notice or pay / forgo one month's salary in lieu of notice period while resigning the job. It is desirable that being a teaching faculty, you do not leave the job when the academic session is in progress.

11. a) If it is observed that your performance is not satisfactory / your behavior is not in the interest of the institute / trust / you commit breach of terms and conditions governing your appointment / you are found medically unfit (physically/mentally), your services shall be terminated without giving any notice period.

b) Your continuous unauthorized absence from duty for more than **fifteen days** shall lead to automatic termination of your services from the date you remain absent from duties.

**c) In view of this appointment order, the previous order stands cancelled.**

d) While joining the duties you will have to give an undertaking that you have read and understood the terms & conditions governing your appointment and that you will abide by them.

Yours faithfully,

For Dr. D. Y. Patil Educational Enterprises Charitable Trust

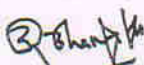
  
(Prof. B. G. Bhandarkar)  
Secretary, DYPEECT.  
Authorized Signatory

**Copy to:**

1. Director, Dr. D Y Patil School of Engineering  
(2 copies - 1. Personal File 2. Accounts Section)
2. Chief Administrative Officer 3. Chief Financial Officer.



D Y PATIL GROUP

**Dr D Y PATIL EDUCATIONAL ENTERPRISES CHARITABLE TRUST**

No.DrDYPEECT /DYPSOE/US/APP/2017/586-33

Date: 08.05.2017

**APPOINTMENT ORDER**

To,  
Ms. Ashwini Ashok Pandagale  
Gajanan nagar ,khandala road  
Tal,chikhali,dist.buldana.

**Subject:** Appointment to the Post of **Assistant Professor in Computer Engg** at **Dr. D Y Patil School of Engineering.**

Sir,

With reference to your application for the post of **Assistant Professor in Computer Engg**, in response to advertisement on 6<sup>th</sup> February, 2017 in Indian Express and Loksatta and subsequent interview on 26<sup>th</sup> March, 2017 before Selection Committee constituted by Savitribai Phule Pune University. We have pleasure in informing you that you are selected by the committee and appointed as **Assistant Professor in Computer Engg** at Dr. D Y Patil School of Engineering, Dr. D. Y. Patil Knowledge City, Charholi Bk, Via Lohegaon, Pune 412 105. The Appointment is subject to the following terms & conditions;

1. This appointment is effective from the date of your joining the duties. You will have to join the duties within **15 days** from the date of this appointment order *i.e.* **by 15<sup>th</sup> May, 2017**. In the event you do not join the duties within this time limit it will be assumed that you do not intend to join the duties and the appointment order issued in your favour will stand automatically cancelled .

However in case you need an extension of time limit for joining the duties you will have to apply in writing for grant of extension stating the reasons for the same and indicating the date on which you intend to join the duties. The request for grant of extension of time limit for joining the duties of the post shall be considered and you will be informed in the matter. The decision of the management of the Dr. D Y Patil School of Engineering shall be final.

2. You will be governed by the Maharashtra Universities Act , statues, ordinances, rules & regulations , code of conduct, laid down by the Savitribai Phule Pune University, Government of Maharashtra and service rules of the Trust and will be responsible to the Director of the Institute for discharge of your duties.

3. The post is for **SC** category and since you belong to **SC** category you are appointed in clear vacancy on fulltime basis and you will be on probation for a period of two years from the date of joining the duties subject to approval by Savitribai Phule Pune University. The continuation beyond probation period will be subject to your satisfactory completion of probation.

4. You will be paid basic salary of **Rs. 15600/-** (in words Rs. Fifteen Thousand Six Hundred Only) plus Academic Grade Pay of **Rs. 06,000/-** (Rs. Six Thousand Only) per month in the pay scale of **Rs. 15600-39100**.

The Salary payment will be subject to deduction of statutory taxes as applicable.

  
13/07/2017  
Received [PTO]

5. You will have to perform duties as mentioned below:

- a) To teach the subject/s assigned to you by the Head of Department/ Institute (theory as well as practicals) in accordance with syllabus of the Savitribai Phule Pune University.
- b) To carry out any other duties as may be assigned to you from time to time by the Head of Department / Institute for smooth conduct of academic and allied co-curricular activities as well as conduct of various institute level and university examinations.
- c) To participate in various skill development / reorientation / training programmes.

6. You shall undergo medical examination before Medical Officer attached with Dr. D Y Patil Knowledge City within three months from the date of joining the duties. The appointment shall be provisional and conditional, pending submission of Medical Certificate stating that you are free from any contagious disease and you are physically fit for employment as the staff of the Institute.

7. You will not engage yourself in any private tuitions or private coaching classes, will not engage yourself in any other job, paid or honorary, full time or part time, while in the service of the institute - You will not undertake any R & D or consultancy work and not register for any degree / diploma / certificate course without approval of the competent authority of the Trust.

8. While joining the duties you will have to submit a) Last Pay Slip from the previous Employer b) Two recent pass-post size photographs c) Two copies of the certificates in support of your qualifications & experience.

9. You will have to submit your correct mailing address while joining the duties and also inform in writing to the Head of the Institute about subsequent changes, if there be any. The communication sent by RPAD on the address given by you shall be deemed to have been received by you.

10. You will have to give one months notice or pay / forgo one month's salary in lieu of notice period while resigning the job. It is desirable that being a teaching faculty, you do not leave the job when the academic session is in progress.

11. a) If it is observed that your performance is not satisfactory / your behavior is not in the interest of the institute / trust / you commit breach of terms and conditions governing your appointment / you are found medically unfit (physically/mentally), your services shall be terminated without giving any notice period.

b) Your continuous unauthorized absence from duty for more than **fifteen days** shall lead to automatic termination of your services from the date you remain absent from duties.

**c) In view of this appointment order, the previous order stands cancelled.**

d) While joining the duties you will have to give an undertaking that you have read and understood the terms & conditions governing your appointment and that you will abide by them.

Yours faithfully,

*For Dr. D. Y. Patil Educational Enterprises Charitable Trust*

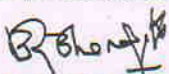

**(Prof. B. G. Bhandarkar)**  
**Secretary, DYPEECT.**  
Authorized Signatory

**Copy to:**

1. Director, Dr. D Y Patil School of Engineering  
(2 copies - 1. Personal File 2. Accounts Section)
2. Chief Administrative Officer 3. Chief Financial Officer.



D Y PATIL GROUP

**Dr D Y PATIL EDUCATIONAL ENTERPRISES CHARITABLE TRUST**

No.DrDYPECT /DYPSOE/US/APP/2017/526-30

Date: 08.05.2017

**APPOINTMENT ORDER**

To,  
Mr. Chaityanya Bhosale  
C/O Shivaji Gavade, Santragar  
Lohegaon Pune.

**Subject: Appointment to the Post of Assistant Professor in Computer Engg at Dr. D Y Patil School of Engineering.**

Sir,

With reference to your application for the post of **Assistant Professor in Computer Engg**, in response to advertisement on 6<sup>th</sup> February, 2017 in Indian Express and Loksatta and subsequent interview on 26<sup>th</sup> March, 2017 before Selection Committee constituted by Savitribai Phule Pune University. We have pleasure in informing you that you are selected by the committee and appointed as **Assistant Professor in Computer Engg** at Dr. D Y Patil School of Engineering, Dr. D. Y. Patil Knowledge City, Charholi Bk, Via Lohegaon, Pune 412 105. The Appointment is subject to the following terms & conditions;

1. This appointment is effective from the date of your joining the duties. You will have to join the duties within **15 days** from the date of this appointment order *i.e.* **by 15<sup>th</sup> May, 2017**. In the event you do not join the duties within this time limit it will be assumed that you do not intend to join the duties and the appointment order issued in your favour will stand automatically cancelled.

However in case you need an extension of time limit for joining the duties you will have to apply in writing for grant of extension stating the reasons for the same and indicating the date on which you intend to join the duties. The request for grant of extension of time limit for joining the duties of the post shall be considered and you will be informed in the matter. The decision of the management of the Dr. D Y Patil School of Engineering shall be final.

2. You will be governed by the Maharashtra Universities Act, statues, ordinances, rules & regulations, code of conduct, laid down by the Savitribai Phule Pune University, Government of Maharashtra and service rules of the Trust and will be responsible to the Director of the Institute for discharge of your duties.

3. The post is for **Open PH** category and since you belong to **Open PH** category you are appointed in clear vacancy on fulltime basis and you will be on probation for a period of two years from the date of joining the duties subject to approval by Savitribai Phule Pune University. The continuation beyond probation period will be subject to your satisfactory completion of probation.

4. You will be paid basic salary of **Rs. 15600/-** (in words Rs. Fifteen Thousand Six Hundred Only) plus Academic Grade Pay of **Rs. 06,000/-** (Rs. Six Thousand Only) per month in the pay scale of **Rs.-15600-39100**.

The Salary payment will be subject to deduction of statutory taxes as applicable.

[PTO]

Received  
Chaityanya  
3/7/17

5. You will have to perform duties as mentioned below:

- a) To teach the subject/s assigned to you by the Head of Department/ Institute (theory as well as practicals) in accordance with syllabus of the Savitribai Phule Pune University.
- b) To carry out any other duties as may be assigned to you from time to time by the Head of Department / Institute for smooth conduct of academic and allied co-curricular activities as well as conduct of various institute level and university examinations.
- c) To participate in various skill development / reorientation / training programmes.

6. You shall undergo medical examination before Medical Officer attached with Dr. D Y Patil Knowledge City within three months from the date of joining the duties. The appointment shall be provisional and conditional, pending submission of Medical Certificate stating that you are free from any contagious disease and you are physically fit for employment as the staff of the Institute.

7. You will not engage yourself in any private tuitions or private coaching classes, will not engage yourself in any other job, paid or honorary, full time or part time, while in the service of the institute . You will not undertake any R & D or consultancy work and not register for any degree / diploma / certificate course without approval of the competent authority of the Trust.

8. While joining the duties you will have to submit a) Last Pay Slip from the previous Employer b) Two recent pass-post size photographs c) Two copies of the certificates in support of your qualifications & experience.

9. You will have to submit your correct mailing address while joining the duties and also inform in writing to the Head of the Institute about subsequent changes, if there be any. The communication sent by RPAD on the address given by you shall be deemed to have been received by you.

10. You will have to give one months notice or pay / forgo one month's salary in lieu of notice period while resigning the job. It is desirable that being a teaching faculty, you do not leave the job when the academic session is in progress.

11. a) If it is observed that your performance is not satisfactory / your behavior is not in the interest of the institute / trust / you commit breach of terms and conditions governing your appointment / you are found medically unfit (physically/mentally), your services shall be terminated without giving any notice period.

b) Your continuous unauthorized absence from duty for more than **fifteen days** shall lead to automatic termination of your services from the date you remain absent from duties.

**c) In view of this appointment order, the previous order stands cancelled.**

d) While joining the duties you will have to give an undertaking that you have read and understood the terms & conditions governing your appointment and that you will abide by them.

Yours faithfully,

*For Dr. D. Y. Patil Educational Enterprises Charitable Trust*

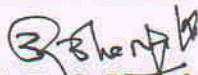
  
(Prof. B. G. Bhandarkar)  
Secretary, DYPEECT.  
Authorized Signatory

**Copy to:**

1. Director, Dr. D Y Patil School of Engineering  
(2 copies - 1. Personal File 2. Accounts Section)
2. Chief Administrative Officer 3. Chief Financial Officer.



D Y PATIL GROUP

**Dr D Y PATIL EDUCATIONAL ENTERPRISES CHARITABLE TRUST**

No.DrDYPEECT /DYP SOE/US/APP/2017/586-34

Date: 08.05.2017

**APPOINTMENT ORDER**

To,  
Ms. Vandan Tulshidas Chavan  
Chavan footwear, near shahu highschool  
Ichalkaranji kolahapur.

**Subject:** Appointment to the Post of **Assistant Professor in Computer Engg** at **Dr. D Y Patil School of Engineering.**

Sir,

With reference to your application for the post of **Assistant Professor Computer Engg**, in response to advertisement on 6<sup>th</sup> February, 2017 in Indian Express and Loksatta and subsequent interview on 26<sup>th</sup> March, 2017 before Selection Committee constituted by Savitribai Phule Pune University. We have pleasure in informing you that you are selected by the committee and appointed as **Assistant Professor in Computer Engg** at Dr. D Y Patil School of Engineering, Dr. D. Y. Patil Knowledge City, Charholi Bk, Via Lohegaon, Pune 412 105. The Appointment is subject to the following terms & conditions;

1. This appointment is effective from the date of your joining the duties. You will have to join the duties within **15 days** from the date of this appointment order *i.e.* **by 15<sup>th</sup> May, 2017**. In the event you do not join the duties within this time limit it will be assumed that you do not intend to join the duties and the appointment order issued in your favour will stand automatically cancelled.

However in case you need an extension of time limit for joining the duties you will have to apply in writing for grant of extension stating the reasons for the same and indicating the date on which you intend to join the duties. The request for grant of extension of time limit for joining the duties of the post shall be considered and you will be informed in the matter. The decision of the management of the Dr. D Y Patil School of Engineering shall be final.

2. You will be governed by the Maharashtra Universities Act, statues, ordinances, rules & regulations, code of conduct, laid down by the Savitribai Phule Pune University, Government of Maharashtra and service rules of the Trust and will be responsible to the Director of the Institute for discharge of your duties.

3. The post is for **SC** category and since you belong to **SC** category you are appointed in clear vacancy on fulltime basis and you will be on probation for a period of two years from the date of joining the duties subject to approval by Savitribai Phule Pune University. The continuation beyond probation period will be subject to your satisfactory completion of probation.

4. You will be paid basic salary of **Rs. 16250/-** (in words Rs. Sixteen Thousand Two Hundred Fifty Only) plus Academic Grade Pay of **Rs. 06,000/-** (Rs. Six Thousand Only) per month in the pay scale of **Rs. 15600-39100**.

The Salary payment will be subject to deduction of statutory taxes as applicable.

[PTO]



5. You will have to perform duties as mentioned below:

- a) To teach the subject/s assigned to you by the Head of Department/ Institute (theory as well as practicals) in accordance with syllabus of the Savitribai Phule Pune University.
- b) To carry out any other duties as may be assigned to you from time to time by the Head of Department / Institute for smooth conduct of academic and allied co-curricular activities as well as conduct of various institute level and university examinations.
- c) To participate in various skill development / reorientation / training programmes.

6. You shall undergo medical examination before Medical Officer attached with Dr. D Y Patil Knowledge City within three months from the date of joining the duties. The appointment shall be provisional and conditional, pending submission of Medical Certificate stating that you are free from any contagious disease and you are physically fit for employment as the staff of the Institute.

7. You will not engage yourself in any private tuitions or private coaching classes, will not engage yourself in any other job, paid or honorary, full time or part time, while in the service of the institute . You will not undertake any R & D or consultancy work and not register for any degree / diploma / certificate course without approval of the competent authority of the Trust.

8. While joining the duties you will have to submit a) Last Pay Slip from the previous Employer b) Two recent pass-post size photographs c) Two copies of the certificates in support of your qualifications & experience.

9. You will have to submit your correct mailing address while joining the duties and also inform in writing to the Head of the Institute about subsequent changes, if there be any. The communication sent by RPAD on the address given by you shall be deemed to have been received by you.

10. You will have to give one months notice or pay / forgo one month's salary in lieu of notice period while resigning the job. It is desirable that being a teaching faculty, you do not leave the job when the academic session is in progress.

11. a) If it is observed that your performance is not satisfactory / your behavior is not in the interest of the institute / trust / you commit breach of terms and conditions governing your appointment / you are found medically unfit (physically/mentally), your services shall be terminated without giving any notice period.

b) Your continuous unauthorized absence from duty for more than **fifteen days** shall lead to automatic termination of your services from the date you remain absent from duties.

**c) In view of this appointment order, the previous order stands cancelled.**

d) While joining the duties you will have to give an undertaking that you have read and understood the terms & conditions governing your appointment and that you will abide by them.

Yours faithfully,

*For Dr. D. Y. Patil Educational Enterprises Charitable Trust*

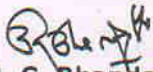

(Prof. B. G. Bhandarkar)  
Secretary, DYPEECT.  
Authorized Signatory

**Copy to:**

1. Director, Dr. D Y Patil School of Engineering  
(2 copies - 1. Personal File 2. Accounts Section)
2. Chief Administrative Officer 3. Chief Financial Officer.



**D Y PATIL GROUP**

**Dr D Y PATIL EDUCATIONAL ENTERPRISES CHARITABLE TRUST**

Ref.ADYPKC/SOE/AO/T/MD/2020-21/13

Date: 10.08.2020

To,  
**Ms. Monika Yograj Dangore**  
A-901, Revel Orchid,  
Opposite D.Y.Patil Knowledge City,  
Dhanori, Pune  
Email- dangore.monika@gmail.com  
Contact- 9545554530

**Appointment Order**

**Ms. Monika Yograj Dangore,**

Following your application and subsequent interview for the post of **Assistant Professor**, I am pleased to inform you that the Management has appointed you as **Assistant Professor in Computer Engineering Department at Dr. D Y Patil School of Engineering**. The terms & conditions of the appointment are as follows.

- 1) Your services are governed by the Maharashtra Universities Act, statutes, ordinances, rules & regulations, code of conduct, laid down by the Savitribai Phule Pune University, Government of Maharashtra and service rules of the Trust and will be responsible to the Principal/Director of the Institute for discharge of your duties.
- 2) Your appointment is on **purely temporary basis** for a period of **Academic Year 2020-21 (i.e. upto 31<sup>st</sup> May 2021 only)** from the date of joining i.e.10<sup>th</sup> August 2020.
- 3) You will be paid consolidated monthly salary of **Rs. 36,950 Only (Rs Thirty Six Thousand Nine Hundred Fifty Only)**. No other allowances will be admissible. The salary payment will be subject to statutory deduction of taxes as applicable.
- 4) Your appointment is subject to the minimum numbers of the students and the sufficient workload prescribed for the post.
- 5) Your appointment is on purely temporary basis and will automatically come to an end on the expiry of tenure and in any such event; you shall not claim any right to be continued in the services. You shall not claim to be a regular/permanent employee of the Institute/College. At any time during the tenure of your services or after termination thereof, in any manner whatsoever, and shall not claim automatic re-appointment to the said post after expiry of the tenure of your services and you will not be eligible for any retiral benefits.
- 6) You shall submit the certified true copies of relevant documents such as birth certificate, mark sheets, experience certificates, Approval Letters, relieving certificate, Aadhar Card, PAN card, Last Pay Slip from the previous Employer before joining the duties.
- 7) You will produce 2 passport size recent photographs.
- 8) You are required to give the correct mailing address as soon as you join your duties. It will be presumed that any letter sent by Registered Post Acknowledgement Due (RPAD) or Speed Post or E-Mail on the address given, shall be deemed to have been acknowledged duly signed by you.
- 9) You are entitled Casual Leave as per Rules & Regulation of DYPEECT, subject to changes from time to time.
- 10) You are entitled for Medical Leave only after completion of one-year regular services and as per Rules & Regulation of DYPEECT, subject to changes from time to time.
- 11) If you want to leave the service during the tenure of your appointment, you will have to give one month's notice in writing to the Management. A sum equal to your one months' salary will be deducted or you will need to deposit the same amount to employer in case you resign without serving a one months' notice period. It is desirable that being a teaching faculty, you do not leave the job when the academic session is in progress.
- 12) You will submit to the office the medical fitness certificate from the Registered Medical panel appointed by the DYPEECT before joining your duties.

Page 1 of 2

Received  
31/8/20

- 13) You will not conduct or engage yourself in private tuitions or private coaching classes.
- 14) You will not engage yourself in any other paid job, full time, part time, honorary or otherwise during the continuance of your service in this Institute/College. You will not undertake any R & D or consultancy work and not register for any degree / diploma / certificate course without approval of the competent authority of the Trust.
- 15) You will not appear for any examinations/Admission without prior permission of the management in service.
- 16) You will not take any active part in the politics, neither involved directly or indirectly in illegal financial matters.
- 17) Your services are transferable within the trust organization only.
- 18) You will not directly or indirectly get yourself involved in any of the anti-activities against the management which may cause any harm to the institute/college or the management.
- 19) Your behavior with colleagues and entire institute/college staff should be polite, co-operative and gentle.
- 20) You will not form any union or organization amongst yourself and colleagues.
- 21) You will not process any letters either signed by you or signed jointly on any issues against the Management/Authorities without prior permission of the Principal/Director. Also, you will not approach to any authorities connected to the Institute/ College / Trust without prior permission of the Principal / Director.
- 22) You will put your grievances to the Management through Principal / Director only.
- 23) You will have to carry out the duties / work assigned to you by the Principal / Director and the Management besides your teaching work / routine work.
- 24) If you found absent continuously for more than 15 days without prior written permission from the Principal/Director, your services will stand terminated automatically and no further correspondence will be entertained thereafter.
- 25) Any information given in the application form if found incorrect contradictory at any time after the appointment, your services will be terminated forthwith, and no further correspondence will be entertained thereafter.
- 26) Progress Report: You will submit your academic progress report and other activities, seminars, presentation of papers, workshop, Self Appraisal etc. twice every year in the months of April and November.
- 27) If it is observed that your performance is not satisfactory / your behavior is not in the interest of the institute or College or trust / you commit breach of terms and conditions as mentioned in your appointment / you are found medically unfit (physically/mentally), your services shall be terminated without giving any notice period.
- 28) You will have to communicate your acceptance in writing to the Management/Director/Principal **within two weeks** from the date of receipt of Order of Appointment, failing which your appointment is liable to be withdrawal / cancelled. However, in case you need an extension of time limit for joining the duties you will have to apply in writing for grant of extension stating the reasons for the same and indicating the date on which you intend to join the duties. The request for grant of extension of time limit for joining the duties for the post shall be considered and you will be informed in the matter. The decision of the management of the **Dr. D Y Patil School of Engineering** shall be final.
- 29) If you are found guilty of violation of any terms & conditions mentioned above you will be liable for disciplinary action and punishment decided by the Management/Director/ Principal as provided in the Rules & Regulations.
- 30) In view of this appointment order, the previous appointment order/s stands cancelled.
- 31) Any dispute arises in the service will be dealt legally in jurisdiction of Pune City only.

*For Dr. D Y Patil Educational Enterprises Charitable Trust*

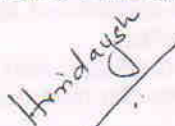
  
**Hrridaysh Deshpande**  
**Authorized Signatory**



**Copy to:**

- 1 Master File DYPEECT.
- 2 Principal, Dr. D Y Patil School of Engineering  
(Two Copies: [1] Personal File [2] Accounts Section).
- 3 Chief Financial Officer, DYPEECT.



D Y PATIL GROUP

Dr D Y PATIL EDUCATIONAL ENTERPRISES CHARITABLE TRUST

Ref.ADYPKC/SOE/AO/T/AM/2020-21/14

Date: 10.08.2020

To,  
Ms. Ajita Arvind Mahapadi  
Swapnपुरी Sr No 52,  
Plot No 3, Lane No 7,  
Bhairav Nagar, Dhanori Road,  
Pune  
Email- [ajita\\_mahapadi@rediff.com](mailto:ajita_mahapadi@rediff.com)  
Contact- 7757037346

Appointment Order

Ms. Ajita Arvind Mahapadi,

Following your application and subsequent interview for the post of **Assistant Professor**, I am pleased to inform you that the Management has appointed you as **Assistant Professor in Computer Engineering Department at Dr. D Y Patil School of Engineering**. The terms & conditions of the appointment are as follows.

- 1) Your services are governed by the Maharashtra Universities Act, statues, ordinances, rules & regulations, code of conduct, laid down by the Savitribai Phule Pune University, Government of Maharashtra and service rules of the Trust and will be responsible to the Principal/Director of the Institute for discharge of your duties.
- 2) Your appointment is on **purely temporary basis** for a period of **Academic Year 2020-21 (i.e. upto 31<sup>st</sup> May 2021 only)** from the date of joining i.e.10<sup>th</sup> August 2020.
- 3) You will be paid consolidated monthly salary of **Rs. 36,950 Only (Rs Thirty Six Thousand Nine Hundred Fifty Only)**. No other allowances will be admissible. The salary payment will be subject to statutory deduction of taxes as applicable.
- 4) Your appointment is subject to the minimum numbers of the students and the sufficient workload prescribed for the post.
- 5) Your appointment is on purely temporary basis and will automatically come to an end on the expiry of tenure and in any such event; you shall not claim any right to be continued in the services. You shall not claim to be a regular/permanent employee of the Institute/College. At any time during the tenure of your services or after termination thereof, in any manner whatsoever, and shall not claim automatic re-appointment to the said post after expiry of the tenure of your services and you will not be eligible for any retiral benefits.
- 6) You shall submit the certified true copies of relevant documents such as birth certificate, mark sheets, experience certificates, Approval Letters, reliving certificate, Aadhar Card, PAN card, Last Pay Slip from the previous Employer before joining the duties.
- 7) You will produce 2 passport size recent photographs.
- 8) You are required to give the correct mailing address as soon as you join your duties. It will be presumed that any letter sent by Registered Post Acknowledgement Due (RPAD) or Speed Post or E-Mail on the address given, shall be deemed to have been acknowledged duly signed by you.
- 9) You are entitled Casual Leave as per Rules & Regulation of DYPEECT, subject to changes from time to time.
- 10) You are entitled for Medical Leave only after completion of one-year regular services and as per Rules & Regulation of DYPEECT, subject to changes from time to time.
- 11) If you want to leave the service during the tenure of your appointment, you will have to give one month's notice in writing to the Management. A sum equal to your one months' salary will be deducted or you will need to deposit the same amount to employer in case you resign without serving a one months' notice period. It is desirable that being a teaching faculty, you do not leave the job when the academic session is in progress.
- 12) You will submit to the office the medical fitness certificate from the Registered Medical panel appointed by the DYPEECT before joining your duties.

Received  
Ajita  
16/07/2021

Page 1 of 2

- 13) You will not conduct or engage yourself in private tuitions or private coaching classes.
- 14) You will not engage yourself in any other paid job, full time, part time, honorary or otherwise during the continuance of your service in this Institute/College. You will not undertake any R & D or consultancy work and not register for any degree / diploma / certificate course without approval of the competent authority of the Trust.
- 15) You will not appear for any examinations/Admission without prior permission of the management in service.
- 16) You will not take any active part in the politics, neither involved directly or indirectly in illegal financial matters.
- 17) Your services are transferable within the trust organization only.
- 18) You will not directly or indirectly get yourself involved in any of the anti-activities against the management which may cause any harm to the institute/college or the management.
- 19) Your behavior with colleagues and entire institute/college staff should be polite, co-operative and gentle.
- 20) You will not form any union or organization amongst yourself and colleagues.
- 21) You will not process any letters either signed by you or signed jointly on any issues against the Management/Authorities without prior permission of the Principal/Director. Also, you will not approach to any authorities connected to the Institute/ College / Trust without prior permission of the Principal / Director.
- 22) You will put your grievances to the Management through Principal / Director only.
- 23) You will have to carry out the duties / work assigned to you by the Principal / Director and the Management besides your teaching work / routine work.
- 24) If you found absent continuously for more than 15 days without prior written permission from the Principal/Director, your services will stand terminated automatically and no further correspondence will be entertained thereafter.
- 25) Any information given in the application form if found incorrect contradictory at any time after the appointment, your services will be terminated forthwith, and no further correspondence will be entertained thereafter.
- 26) Progress Report: You will submit your academic progress report and other activities, seminars, presentation of papers, workshop, Self Appraisal etc. twice every year in the months of April and November.
- 27) If it is observed that your performance is not satisfactory / your behavior is not in the interest of the institute or College or trust / you commit breach of terms and conditions as mentioned in your appointment / you are found medically unfit (physically/mentally), your services shall be terminated without giving any notice period.
- 28) You will have to communicate your acceptance in writing to the Management/Director/Principal **within two weeks** from the date of receipt of Order of Appointment, failing which your appointment is liable to be withdrawal / cancelled. However, in case you need an extension of time limit for joining the duties you will have to apply in writing for grant of extension stating the reasons for the same and indicating the date on which you intend to join the duties. The request for grant of extension of time limit for joining the duties for the post shall be considered and you will be informed in the matter. The decision of the management of the **Dr. D Y Patil School of Engineering** shall be final.
- 29) If you are found guilty of violation of any terms & conditions mentioned above you will be liable for disciplinary action and punishment decided by the Management/Director/ Principal as provided in the Rules & Regulations.
- 30) In view of this appointment order, the previous appointment order/s stands cancelled.
- 31) Any dispute arises in the service will be dealt legally in jurisdiction of Pune City only.

*For Dr. D Y Patil Educational Enterprises Charitable Trust*

*Hridaysh*  
**Hridaysh Deshpande**  
**Authorized Signatory**



**Copy to:**

- 1 Master File DYPEECT.
- 2 Principal, Dr. D Y Patil School of Engineering  
(Two Copies: [1] Personal File [2] Accounts Section).
- 3 Chief Financial Officer, DYPEECT.



**Dr D Y PATIL EDUCATIONAL ENTERPRISES CHARITABLE TRUST**

Ref.ADYPKC/SOE/AO/T/PS/2020-21/ 15

Date: 17.08.2020

To,  
**Mr. Prashant Prabhakar Sagare**  
Flat No. A-103,  
Mahalaxmi Nagar,  
Warje, Pune  
Email- prashantsagare.578@gmail.com  
Contact- 9561988833

**Appointment Order**

**Mr. Prashant Prabhakar Sagare,**

Following your application and subsequent interview for the post of **Assistant Professor**, I am pleased to inform you that the Management has appointed you as **Assistant Professor in Computer Engineering Department at Dr. D Y Patil School of Engineering**. The terms & conditions of the appointment are as follows.

- 1) Your services are governed by the Maharashtra Universities Act, statues, ordinances, rules & regulations, code of conduct, laid down by the Savitribai Phule Pune University, Government of Maharashtra and service rules of the Trust and will be responsible to the Principal/Director of the Institute for discharge of your duties.
- 2) Your appointment is on **purely temporary basis** for a period of **Academic Year 2020-21 (i.e. upto 31<sup>st</sup> May 2021 only)** from the date of joining i.e.17<sup>th</sup> August 2020.
- 3) You will be paid consolidated monthly salary of **Rs. 36,300 Only (Rs Thirty Six Thousand Three Hundred Only)**. No other allowances will be admissible. The salary payment will be subject to statutory deduction of taxes as applicable.
- 4) Your appointment is subject to the minimum numbers of the students and the sufficient workload prescribed for the post.
- 5) Your appointment is on purely temporary basis and will automatically come to an end on the expiry of tenure and in any such event; you shall not claim any right to be continued in the services. You shall not claim to be a regular/permanent employee of the Institute/College. At any time during the tenure of your services or after termination thereof, in any manner whatsoever, and shall not claim automatic re-appointment to the said post after expiry of the tenure of your services and you will not be eligible for any retiral benefits.
- 6) You shall submit the certified true copies of relevant documents such as birth certificate, mark sheets, experience certificates, Approval Letters, reliving certificate, Aadhar Card, PAN card, Last Pay Slip from the previous Employer before joining the duties.
- 7) You will produce 2 passport size recent photographs.
- 8) You are required to give the correct mailing address as soon as you join your duties. It will be presumed that any letter sent by Registered Post Acknowledgement Due (RPAD) or Speed Post or E-Mail on the address given, shall be deemed to have been acknowledged duly signed by you.
- 9) You are entitled Casual Leave as per Rules & Regulation of DYPEECT, subject to changes from time to time.
- 10) You are entitled for Medical Leave only after completion of one-year regular services and as per Rules & Regulation of DYPEECT, subject to changes from time to time.
- 11) If you want to leave the service during the tenure of your appointment, you will have to give one month's notice in writing to the Management. A sum equal to your one months' salary will be deducted or you will need to deposit the same amount to employer in case you resign without serving a one months' notice period. It is desirable that being a teaching faculty, you do not leave the job when the academic session is in progress.
- 12) You will submit to the office the medical fitness certificate from the Registered Medical panel appointed by the DYPEECT before joining your duties.

*Received*  
*25.8.2020*

- 13) You will not conduct or engage yourself in private tuitions or private coaching classes.
- 14) You will not engage yourself in any other paid job, full time, part time, honorary or otherwise during the continuance of your service in this Institute/College. You will not undertake any R & D or consultancy work and not register for any degree / diploma / certificate course without approval of the competent authority of the Trust.
- 15) You will not appear for any examinations/Admission without prior permission of the management in service.
- 16) You will not take any active part in the politics, neither involved directly or indirectly in illegal financial matters.
- 17) Your services are transferable within the trust organization only.
- 18) You will not directly or indirectly get yourself involved in any of the anti-activities against the management which may cause any harm to the institute/college or the management.
- 19) Your behavior with colleagues and entire institute/college staff should be polite, co-operative and gentle.
- 20) You will not form any union or organization amongst yourself and colleagues.
- 21) You will not process any letters either signed by you or signed jointly on any issues against the Management/Authorities without prior permission of the Principal/Director. Also, you will not approach to any authorities connected to the Institute/ College / Trust without prior permission of the Principal / Director.
- 22) You will put your grievances to the Management through Principal / Director only.
- 23) You will have to carry out the duties / work assigned to you by the Principal / Director and the Management besides your teaching work / routine work.
- 24) If you found absent continuously for more than 15 days without prior written permission from the Principal/Director, your services will stand terminated automatically and no further correspondence will be entertained thereafter.
- 25) Any information given in the application form if found incorrect contradictory at any time after the appointment, your services will be terminated forthwith, and no further correspondence will be entertained thereafter.
- 26) Progress Report: You will submit your academic progress report and other activities, seminars, presentation of papers, workshop, Self Appraisal etc. twice every year in the months of April and November.
- 27) If it is observed that your performance is not satisfactory / your behavior is not in the interest of the institute or College or trust / you commit breach of terms and conditions as mentioned in your appointment / you are found medically unfit (physically/mentally), your services shall be terminated without giving any notice period.
- 28) You will have to communicate your acceptance in writing to the Management/Director/Principal **within two weeks** from the date of receipt of Order of Appointment, failing which your appointment is liable to be withdrawal / cancelled. However, in case you need an extension of time limit for joining the duties you will have to apply in writing for grant of extension stating the reasons for the same and indicating the date on which you intend to join the duties. The request for grant of extension of time limit for joining the duties for the post shall be considered and you will be informed in the matter. The decision of the management of the **Dr. D Y Patil School of Engineering** shall be final.
- 29) If you are found guilty of violation of any terms & conditions mentioned above you will be liable for disciplinary action and punishment decided by the Management/Director/ Principal as provided in the Rules & Regulations.
- 30) In view of this appointment order, the previous appointment order/s stands cancelled.
- 31) Any dispute arises in the service will be dealt legally in jurisdiction of Pune City only.

*For Dr. D Y Patil Educational Enterprises Charitable Trust*

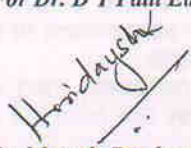
  
**Hridaysh Deshpande**  
**Authorized Signatory**



**Copy to:**

- 1 Master File DYPEECT.
- 2 Principal, Dr. D Y Patil School of Engineering  
(Two Copies: [1] Personal File [2] Accounts Section).
- 3 Chief Financial Officer, DYPEECT.



D Y PATIL GROUP

**Dr D Y PATIL EDUCATIONAL ENTERPRISES CHARITABLE TRUST**

Ref.ADYPKC/SOE/AO/T/FB/2020-21/ 16

Date: 10.08.2020

To,  
Mr. Faraz Aarif Bagwan  
Building No. 92, Flat 1-A,  
Kausar Baug Society,  
Kondhwa Khurd.  
Email- [farazbagwan11@gmail.com](mailto:farazbagwan11@gmail.com)  
Contact- 7304388919

**Appointment Order**

**Mr. Faraz Aarif Bagwan,**

Following your application and subsequent interview for the post of **Assistant Professor**, I am pleased to inform you that the Management has appointed you as **Assistant Professor in Computer Engineering Department at Dr. D Y Patil School of Engineering**. The terms & conditions of the appointment are as follows.

- 1) Your services are governed by the Maharashtra Universities Act, statues, ordinances, rules & regulations, code of conduct, laid down by the Savitribai Phule Pune University, Government of Maharashtra and service rules of the Trust and will be responsible to the Principal/Director of the Institute for discharge of your duties.
- 2) Your appointment is on **purely temporary basis** for a period of **Academic Year 2020-21 (i.e. upto 31<sup>st</sup> May 2021 only)** from the date of joining i.e.10<sup>th</sup> August 2020.
- 3) You will be paid consolidated monthly salary of **Rs. 35,000 Only (Rs Thirty Five Thousand Only)**. No other allowances will be admissible. The salary payment will be subject to statutory deduction of taxes as applicable.
- 4) Your appointment is subject to the minimum numbers of the students and the sufficient workload prescribed for the post.
- 5) Your appointment is on purely temporary basis and will automatically come to an end on the expiry of tenure and in any such event; you shall not claim any right to be continued in the services. You shall not claim to be a regular/permanent employee of the Institute/College. At any time during the tenure of your services or after termination thereof, in any manner whatsoever, and shall not claim automatic re-appointment to the said post after expiry of the tenure of your services and you will not be eligible for any retiral benefits.
- 6) You shall submit the certified true copies of relevant documents such as birth certificate, mark sheets, experience certificates, Approval Letters, reliving certificate, Aadhar Card, PAN card, Last Pay Slip from the previous Employer before joining the duties.
- 7) You will produce 2 passport size recent photographs.
- 8) You are required to give the correct mailing address as soon as you join your duties. It will be presumed that any letter sent by Registered Post Acknowledgement Due (RPAD) or Speed Post or E-Mail on the address given, shall be deemed to have been acknowledged duly signed by you.
- 9) You are entitled Casual Leave as per Rules & Regulation of DYPEECT, subject to changes from time to time.
- 10) You are entitled for Medical Leave only after completion of one-year regular services and as per Rules & Regulation of DYPEECT, subject to changes from time to time.
- 11) If you want to leave the service during the tenure of your appointment, you will have to give one month's notice in writing to the Management. A sum equal to your one months' salary will be deducted or you will need to deposit the same amount to employer in case you resign without serving a one months' notice period. It is desirable that being a teaching faculty, you do not leave the job when the academic session is in progress.
- 12) You will submit to the office the medical fitness certificate from the Registered Medical panel appointed by the DYPEECT before joining your duties.

*(Handwritten signature)*  
Received  
28/8/20



- 13) You will not conduct or engage yourself in private tuitions or private coaching classes.
- 14) You will not engage yourself in any other paid job, full time, part time, honorary or otherwise during the continuance of your service in this Institute/College. You will not undertake any R & D or consultancy work and not register for any degree / diploma / certificate course without approval of the competent authority of the Trust.
- 15) You will not appear for any examinations/Admission without prior permission of the management in service.
- 16) You will not take any active part in the politics, neither involved directly or indirectly in illegal financial matters.
- 17) Your services are transferable within the trust organization only.
- 18) You will not directly or indirectly get yourself involved in any of the anti-activities against the management which may cause any harm to the institute/college or the management.
- 19) Your behavior with colleagues and entire institute/college staff should be polite, co-operative and gentle.
- 20) You will not form any union or organization amongst yourself and colleagues.
- 21) You will not process any letters either signed by you or signed jointly on any issues against the Management/Authorities without prior permission of the Principal/Director. Also, you will not approach to any authorities connected to the Institute/ College / Trust without prior permission of the Principal / Director.
- 22) You will put your grievances to the Management through Principal / Director only.
- 23) You will have to carry out the duties / work assigned to you by the Principal / Director and the Management besides your teaching work / routine work.
- 24) If you found absent continuously for more than 15 days without prior written permission from the Principal/Director, your services will stand terminated automatically and no further correspondence will be entertained thereafter.
- 25) Any information given in the application form if found incorrect contradictory at any time after the appointment, your services will be terminated forthwith, and no further correspondence will be entertained thereafter.
- 26) Progress Report: You will submit your academic progress report and other activities, seminars, presentation of papers, workshop, Self Appraisal etc. twice every year in the months of April and November.
- 27) If it is observed that your performance is not satisfactory / your behavior is not in the interest of the institute or College or trust / you commit breach of terms and conditions as mentioned in your appointment / you are found medically unfit (physically/mentally), your services shall be terminated without giving any notice period.
- 28) You will have to communicate your acceptance in writing to the Management/Director/Principal **within two weeks** from the date of receipt of Order of Appointment, failing which your appointment is liable to be withdrawal / cancelled. However, in case you need an extension of time limit for joining the duties you will have to apply in writing for grant of extension stating the reasons for the same and indicating the date on which you intend to join the duties. The request for grant of extension of time limit for joining the duties for the post shall be considered and you will be informed in the matter. The decision of the management of the **Dr. D Y Patil School of Engineering** shall be final.
- 29) If you are found guilty of violation of any terms & conditions mentioned above you will be liable for disciplinary action and punishment decided by the Management/Director/ Principal as provided in the Rules & Regulations.
- 30) In view of this appointment order, the previous appointment order/s stands cancelled.
- 31) Any dispute arises in the service will be dealt legally in jurisdiction of Pune City only.

*For Dr. D Y Patil Educational Enterprises Charitable Trust*

  
**Hridaysh Deshpande**  
**Authorized Signatory**

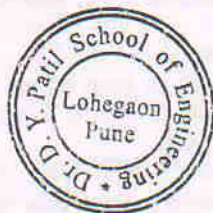

**Copy to:**

- 1 Master File DYPEECT.
- 2 Principal, Dr. D Y Patil School of Engineering  
(Two Copies: [1] Personal File [2] Accounts Section).
- 3 Chief Financial Officer, DYPEECT.



D Y PATIL GROUP

**Dr D Y PATIL EDUCATIONAL ENTERPRISES CHARITABLE TRUST**

Ref.ADYPKC/SOE/AO/T/NM/2020-21/ 17

Date: 10.08.2020

To,  
Mr. Nilesh Mali  
C-303, Shri krishna, Paradise,  
Sector-6 Moshi Pradhikaran,  
Pune  
Email- nileshdmali@gmail.com  
Contact- 8975751261

**Appointment Order**

**Mr. Nilesh Mali,**

Following your application and subsequent interview for the post of **Assistant Professor**, I am pleased to inform you that the Management has appointed you as **Assistant Professor in Computer Engineering Department at Dr. D Y Patil School of Engineering**. The terms & conditions of the appointment are as follows.

- 1) Your services are governed by the Maharashtra Universities Act, statutes, ordinances, rules & regulations, code of conduct, laid down by the Savitribai Phule Pune University, Government of Maharashtra and service rules of the Trust and will be responsible to the Principal/Director of the Institute for discharge of your duties.
- 2) Your appointment is on **purely temporary basis** for a period of **Academic Year 2020-21 (i.e. upto 31<sup>st</sup> May 2021 only)** from the date of joining i.e.10<sup>th</sup> August 2020.
- 3) You will be paid consolidated monthly salary of **Rs. 41,000 Only (Rs Fourty One Thousand Only)**. No other allowances will be admissible. The salary payment will be subject to statutory deduction of taxes as applicable.
- 4) Your appointment is subject to the minimum numbers of the students and the sufficient workload prescribed for the post.
- 5) Your appointment is on purely temporary basis and will automatically come to an end on the expiry of tenure and in any such event; you shall not claim any right to be continued in the services. You shall not claim to be a regular/permanent employee of the Institute/College. At any time during the tenure of your services or after termination thereof, in any manner whatsoever, and shall not claim automatic re-appointment to the said post after expiry of the tenure of your services and you will not be eligible for any retiral benefits.
- 6) You shall submit the certified true copies of relevant documents such as birth certificate, mark sheets, experience certificates, Approval Letters, reliving certificate, Aadhar Card, PAN card, Last Pay Slip from the previous Employer before joining the duties.
- 7) You will produce 2 passport size recent photographs.
- 8) You are required to give the correct mailing address as soon as you join your duties. It will be presumed that any letter sent by Registered Post Acknowledgement Due (RPAD) or Speed Post or E-Mail on the address given, shall be deemed to have been acknowledged duly signed by you.
- 9) You are entitled Casual Leave as per Rules & Regulation of DYPEECT, subject to changes from time to time.
- 10) You are entitled for Medical Leave only after completion of one-year regular services and as per Rules & Regulation of DYPEECT, subject to changes from time to time.
- 11) If you want to leave the service during the tenure of your appointment, you will have to give one month's notice in writing to the Management. A sum equal to your one months' salary will be deducted or you will need to deposit the same amount to employer in case you resign without serving a one months' notice period. It is desirable that being a teaching faculty, you do not leave the job when the academic session is in progress.
- 12) You will submit to the office the medical fitness certificate from the Registered Medical panel appointed by the DYPEECT before joining your duties.

*Received*  
*25/08/2020 mali*

Page 1 of 2

- 13) You will not conduct or engage yourself in private tuitions or private coaching classes.
- 14) You will not engage yourself in any other paid job, full time, part time, honorary or otherwise during the continuance of your service in this Institute/College. You will not undertake any R & D or consultancy work and not register for any degree / diploma / certificate course without approval of the competent authority of the Trust.
- 15) You will not appear for any examinations/Admission without prior permission of the management in service.
- 16) You will not take any active part in the politics, neither involved directly or indirectly in illegal financial matters.
- 17) Your services are transferable within the trust organization only.
- 18) You will not directly or indirectly get yourself involved in any of the anti-activities against the management which may cause any harm to the institute/college or the management.
- 19) Your behavior with colleagues and entire institute/college staff should be polite, co-operative and gentle.
- 20) You will not form any union or organization amongst yourself and colleagues.
- 21) You will not process any letters either signed by you or signed jointly on any issues against the Management/Authorities without prior permission of the Principal/Director. Also, you will not approach to any authorities connected to the Institute/ College / Trust without prior permission of the Principal / Director.
- 22) You will put your grievances to the Management through Principal / Director only.
- 23) You will have to carry out the duties / work assigned to you by the Principal / Director and the Management besides your teaching work / routine work.
- 24) If you found absent continuously for more than 15 days without prior written permission from the Principal/Director, your services will stand terminated automatically and no further correspondence will be entertained thereafter.
- 25) Any information given in the application form if found incorrect contradictory at any time after the appointment, your services will be terminated forthwith, and no further correspondence will be entertained thereafter.
- 26) Progress Report: You will submit your academic progress report and other activities, seminars, presentation of papers, workshop, Self Appraisal etc. twice every year in the months of April and November.
- 27) If it is observed that your performance is not satisfactory / your behavior is not in the interest of the institute or College or trust / you commit breach of terms and conditions as mentioned in your appointment / you are found medically unfit (physically/mentally), your services shall be terminated without giving any notice period.
- 28) You will have to communicate your acceptance in writing to the Management/Director/Principal **within two weeks** from the date of receipt of Order of Appointment, failing which your appointment is liable to be withdrawal / cancelled. However, in case you need an extension of time limit for joining the duties you will have to apply in writing for grant of extension stating the reasons for the same and indicating the date on which you intend to join the duties. The request for grant of extension of time limit for joining the duties for the post shall be considered and you will be informed in the matter. The decision of the management of the **Dr. D Y Patil School of Engineering** shall be final.
- 29) If you are found guilty of violation of any terms & conditions mentioned above you will be liable for disciplinary action and punishment decided by the Management/Director/ Principal as provided in the Rules & Regulations.
- 30) In view of this appointment order, the previous appointment order/s stands cancelled.
- 31) Any dispute arises in the service will be dealt legally in jurisdiction of Pune City only.

For Dr. D Y Patil Educational Enterprises Charitable Trust

  
**Hridaysh Deshpande**  
**Authorized Signatory**



**Copy to:**

- 1 Master File DYPEECT.
- 2 Principal, Dr. D Y Patil School of Engineering  
(Two Copies: [1] Personal File [2] Accounts Section).
- 3 Chief Financial Officer, DYPEECT.



## Dr D Y PATIL EDUCATIONAL ENTERPRISES CHARITABLE TRUST

Ref.ADYPKC/SOE/AO/T/VB/2020-21/ 18

Date: 10.08.2020

To,  
Mr. Vishal Kisan Borate  
Flat No-07, Vrundavan Apartment,  
Right Bhusari, Colony,  
Kothrud,  
Pune  
Email- vkborate88@gmail.com  
Contact- 9130014578

### Appointment Order

Mr. Vishal Kisan Borate,

Following your application and subsequent interview for the post of **Assistant Professor**, I am pleased to inform you that the Management has appointed you as **Assistant Professor in Computer Engineering Department at Dr. D Y Patil School of Engineering**. The terms & conditions of the appointment are as follows.

- 1) Your services are governed by the Maharashtra Universities Act, statues, ordinances, rules & regulations, code of conduct, laid down by the Savitribai Phule Pune University, Government of Maharashtra and service rules of the Trust and will be responsible to the Principal/Director of the Institute for discharge of your duties.
- 2) Your appointment is on **purely temporary basis** for a period of **Academic Year 2020-21 (i.e. upto 31<sup>st</sup> May 2021 only)** from the date of joining i.e.10<sup>th</sup> August 2020.
- 3) You will be paid consolidated monthly salary **of Rs. 36,300 Only (Rs Thirty Six Thousand Three Hundred Only)**. No other allowances will be admissible. The salary payment will be subject to statutory deduction of taxes as applicable.
- 4) Your appointment is subject to the minimum numbers of the students and the sufficient workload prescribed for the post.
- 5) Your appointment is on purely temporary basis and will automatically come to an end on the expiry of tenure and in any such event; you shall not claim any right to be continued in the services. You shall not claim to be a regular/permanent employee of the Institute/College. At any time during the tenure of your services or after termination thereof, in any manner whatsoever, and shall not claim automatic re-appointment to the said post after expiry of the tenure of your services and you will not be eligible for any retiral benefits.
- 6) You shall submit the certified true copies of relevant documents such as birth certificate, mark sheets, experience certificates, Approval Letters, reliving certificate, Aadhar Card, PAN card, Last Pay Slip from the previous Employer before joining the duties.
- 7) You will produce 2 passport size recent photographs.
- 8) You are required to give the correct mailing address as soon as you join your duties. It will be presumed that any letter sent by Registered Post Acknowledgement Due (RPAD) or Speed Post or E-Mail on the address given, shall be deemed to have been acknowledged duly signed by you.
- 9) You are entitled Casual Leave as per Rules & Regulation of DYPEECT, subject to changes from time to time.
- 10) You are entitled for Medical Leave only after completion of one-year regular services and as per Rules & Regulation of DYPEECT, subject to changes from time to time.
- 11) If you want to leave the service during the tenure of your appointment, you will have to give one month's notice in writing to the Management. A sum equal to your one months' salary will be deducted or you will need to deposit the same amount to employer in case you resign without serving a one months' notice period. It is desirable that being a teaching faculty, you do not leave the job when the academic session is in progress.
- 12) You will submit to the office the medical fitness certificate from the Registered Medical panel appointed by the DYPEECT before joining your duties.

Page 1 of 2

Received  
VB  
31/08/2020

- 13) You will not conduct or engage yourself in private tuitions or private coaching classes.
- 14) You will not engage yourself in any other paid job, full time, part time, honorary or otherwise during the continuance of your service in this Institute/College. You will not undertake any R & D or consultancy work and not register for any degree / diploma / certificate course without approval of the competent authority of the Trust.
- 15) You will not appear for any examinations/Admission without prior permission of the management in service.
- 16) You will not take any active part in the politics, neither involved directly or indirectly in illegal financial matters.
- 17) Your services are transferable within the trust organization only.
- 18) You will not directly or indirectly get yourself involved in any of the anti-activities against the management which may cause any harm to the institute/college or the management.
- 19) Your behavior with colleagues and entire institute/college staff should be polite, co-operative and gentle.
- 20) You will not form any union or organization amongst yourself and colleagues.
- 21) You will not process any letters either signed by you or signed jointly on any issues against the Management/Authorities without prior permission of the Principal/Director. Also, you will not approach to any authorities connected to the Institute/ College / Trust without prior permission of the Principal / Director.
- 22) You will put your grievances to the Management through Principal / Director only.
- 23) You will have to carry out the duties / work assigned to you by the Principal / Director and the Management besides your teaching work / routine work.
- 24) If you found absent continuously for more than 15 days without prior written permission from the Principal/Director, your services will stand terminated automatically and no further correspondence will be entertained thereafter.
- 25) Any information given in the application form if found incorrect contradictory at any time after the appointment, your services will be terminated forthwith, and no further correspondence will be entertained thereafter.
- 26) Progress Report: You will submit your academic progress report and other activities, seminars, presentation of papers, workshop, Self Appraisal etc. twice every year in the months of April and November.
- 27) If it is observed that your performance is not satisfactory / your behavior is not in the interest of the institute or College or trust / you commit breach of terms and conditions as mentioned in your appointment / you are found medically unfit (physically/mentally), your services shall be terminated without giving any notice period.
- 28) You will have to communicate your acceptance in writing to the Management/Director/Principal **within two weeks** from the date of receipt of Order of Appointment, failing which your appointment is liable to be withdrawal / cancelled. However, in case you need an extension of time limit for joining the duties you will have to apply in writing for grant of extension stating the reasons for the same and indicating the date on which you intend to join the duties. The request for grant of extension of time limit for joining the duties for the post shall be considered and you will be informed in the matter. The decision of the management of the **Dr. D Y Patil School of Engineering** shall be final.
- 29) If you are found guilty of violation of any terms & conditions mentioned above you will be liable for disciplinary action and punishment decided by the Management/Director/ Principal as provided in the Rules & Regulations.
- 30) In view of this appointment order, the previous appointment order/s stands cancelled.
- 31) Any dispute arises in the service will be dealt legally in jurisdiction of Pune City only.

For Dr. D Y Patil Educational Enterprises Charitable Trust

*Hrridaysh*  
**Hrridaysh Deshpande**  
 Authorized Signatory



**Copy to:**

- 1 Master File DYPEECT.
- 2 Principal, Dr. D Y Patil School of Engineering  
(Two Copies: [1] Personal File [2] Accounts Section).
- 3 Chief Financial Officer, DYPEECT.



**D Y PATIL GROUP**

**Dr D Y PATIL EDUCATIONAL ENTERPRISES CHARITABLE TRUST**

Ref.ADYPKC/SOE/AO/T/NU/2020-21/ 19

Date: 10.08.2020

To,  
**Ms. Niyamat Irfan Ujloomwale**  
Kubeera Park Hsg. Soc. C 5/12,  
Kondhwa road,  
Pune-411040  
Email- niyamatpanjasha@gmail.com  
Contact- 9860805103

**Appointment Order**

**Ms. Niyamat Irfan Ujloomwale,**

Following your application and subsequent interview for the post of **Assistant Professor**, I am pleased to inform you that the Management has appointed you as **Assistant Professor in Computer Engineering Department at Dr. D Y Patil School of Engineering**. The terms & conditions of the appointment are as follows.

- 1) Your services are governed by the Maharashtra Universities Act, statues, ordinances, rules & regulations, code of conduct, laid down by the Savitribai Phule Pune University, Government of Maharashtra and service rules of the Trust and will be responsible to the Principal/Director of the Institute for discharge of your duties.
- 2) Your appointment is on **purely temporary basis** for a period of **Academic Year 2020-21 (i.e. upto 31<sup>st</sup> May 2021 only)** from the date of joining i.e.10<sup>th</sup> August 2020.
- 3) You will be paid consolidated monthly salary of **Rs. 36,300 Only (Rs Thirty Six Thousand Three Hundred Only)**. No other allowances will be admissible. The salary payment will be subject to statutory deduction of taxes as applicable.
- 4) Your appointment is subject to the minimum numbers of the students and the sufficient workload prescribed for the post.
- 5) Your appointment is on purely temporary basis and will automatically come to an end on the expiry of tenure and in any such event; you shall not claim any right to be continued in the services. You shall not claim to be a regular/permanent employee of the Institute/College. At any time during the tenure of your services or after termination thereof, in any manner whatsoever, and shall not claim automatic re-appointment to the said post after expiry of the tenure of your services and you will not be eligible for any retiral benefits.
- 6) You shall submit the certified true copies of relevant documents such as birth certificate, mark sheets, experience certificates, Approval Letters, reliving certificate, Aadhar Card, PAN card, Last Pay Slip from the previous Employer before joining the duties.
- 7) You will produce 2 passport size recent photographs.
- 8) You are required to give the correct mailing address as soon as you join your duties. It will be presumed that any letter sent by Registered Post Acknowledgement Due (RPAD) or Speed Post or E-Mail on the address given, shall be deemed to have been acknowledged duly signed by you.
- 9) You are entitled Casual Leave as per Rules & Regulation of DYPEECT, subject to changes from time to time.
- 10) You are entitled for Medical Leave only after completion of one-year regular services and as per Rules & Regulation of DYPEECT, subject to changes from time to time.
- 11) If you want to leave the service during the tenure of your appointment, you will have to give one month's notice in writing to the Management. A sum equal to your one months' salary will be deducted or you will need to deposit the same amount to employer in case you resign without serving a one months' notice period. It is desirable that being a teaching faculty, you do not leave the job when the academic session is in progress.
- 12) You will submit to the office the medical fitness certificate from the Registered Medical panel appointed by the DYPEECT before joining your duties.

Page 1 of 2

Received  
Niyamat  
3/8/2020

- 13) You will not conduct or engage yourself in private tuitions or private coaching classes.
- 14) You will not engage yourself in any other paid job, full time, part time, honorary or otherwise during the continuance of your service in this Institute/College. You will not undertake any R & D or consultancy work and not register for any degree / diploma / certificate course without approval of the competent authority of the Trust.
- 15) You will not appear for any examinations/Admission without prior permission of the management in service.
- 16) You will not take any active part in the politics, neither involved directly or indirectly in illegal financial matters.
- 17) Your services are transferable within the trust organization only.
- 18) You will not directly or indirectly get yourself involved in any of the anti-activities against the management which may cause any harm to the institute/college or the management.
- 19) Your behavior with colleagues and entire institute/college staff should be polite, co-operative and gentle.
- 20) You will not form any union or organization amongst yourself and colleagues.
- 21) You will not process any letters either signed by you or signed jointly on any issues against the Management/Authorities without prior permission of the Principal/Director. Also, you will not approach to any authorities connected to the Institute/ College / Trust without prior permission of the Principal / Director.
- 22) You will put your grievances to the Management through Principal / Director only.
- 23) You will have to carry out the duties / work assigned to you by the Principal / Director and the Management besides your teaching work / routine work.
- 24) If you found absent continuously for more than 15 days without prior written permission from the Principal/Director, your services will stand terminated automatically and no further correspondence will be entertained thereafter.
- 25) Any information given in the application form if found incorrect contradictory at any time after the appointment, your services will be terminated forthwith, and no further correspondence will be entertained thereafter.
- 26) Progress Report: You will submit your academic progress report and other activities, seminars, presentation of papers, workshop, Self Appraisal etc. twice every year in the months of April and November.
- 27) If it is observed that your performance is not satisfactory / your behavior is not in the interest of the institute or College or trust / you commit breach of terms and conditions as mentioned in your appointment / you are found medically unfit (physically/mentally), your services shall be terminated without giving any notice period.
- 28) You will have to communicate your acceptance in writing to the Management/Director/Principal **within two weeks** from the date of receipt of Order of Appointment, failing which your appointment is liable to be withdrawal / cancelled. However, in case you need an extension of time limit for joining the duties you will have to apply in writing for grant of extension stating the reasons for the same and indicating the date on which you intend to join the duties. The request for grant of extension of time limit for joining the duties for the post shall be considered and you will be informed in the matter. The decision of the management of the **Dr. D Y Patil School of Engineering** shall be final.
- 29) If you are found guilty of violation of any terms & conditions mentioned above you will be liable for disciplinary action and punishment decided by the Management/Director/ Principal as provided in the Rules & Regulations.
- 30) In view of this appointment order, the previous appointment order/s stands cancelled.
- 31) Any dispute arises in the service will be dealt legally in jurisdiction of Pune City only.

*For Dr. D Y Patil Educational Enterprises Charitable Trust*

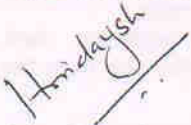
  
**Hridaysh Deshpande**  
**Authorized Signatory**



**Copy to:**

- 1 Master File DYPEECT.
- 2 Principal, Dr. D Y Patil School of Engineering  
(Two Copies: [1] Personal File [2] Accounts Section).
- 3 Chief Financial Officer, DYPEECT.



## Dr D Y PATIL EDUCATIONAL ENTERPRISES CHARITABLE TRUST

Ref.ADYPKC/SOE/AO/T/PS/2020-21/ 2D

Date: 10.08.2020

To,  
Ms. Pooja D Shinde  
S.No. 72/1C/29,  
Samrath nagar,  
New Sangvi, Pune-61  
Email- [poojshinde@gmail.com](mailto:poojshinde@gmail.com)  
Contact- 8600061188

### Appointment Order

Ms. Pooja D Shinde,

Following your application and subsequent interview for the post of **Assistant Professor**, I am pleased to inform you that the Management has appointed you as **Assistant Professor in Computer Engineering Department at Dr. D Y Patil School of Engineering**. The terms & conditions of the appointment are as follows.

- 1) Your services are governed by the Maharashtra Universities Act, statues, ordinances, rules & regulations, code of conduct, laid down by the Savitribai Phule Pune University, Government of Maharashtra and service rules of the Trust and will be responsible to the Principal/Director of the Institute for discharge of your duties.
- 2) Your appointment is on **purely temporary basis** for a period of **Academic Year 2020-21 (i.e. upto 31<sup>st</sup> May 2021 only)** from the date of joining i.e.10<sup>th</sup> August 2020.
- 3) You will be paid consolidated monthly salary of **Rs. 35,000 Only (Rs Thirty Five Thousand Only)**. No other allowances will be admissible. The salary payment will be subject to statutory deduction of taxes as applicable.
- 4) Your appointment is subject to the minimum numbers of the students and the sufficient workload prescribed for the post.
- 5) Your appointment is on purely temporary basis and will automatically come to an end on the expiry of tenure and in any such event; you shall not claim any right to be continued in the services. You shall not claim to be a regular/permanent employee of the Institute/College. At any time during the tenure of your services or after termination thereof, in any manner whatsoever, and shall not claim automatic re-appointment to the said post after expiry of the tenure of your services and you will not be eligible for any retiral benefits.
- 6) You shall submit the certified true copies of relevant documents such as birth certificate, mark sheets, experience certificates, Approval Letters, reliving certificate, Aadhar Card, PAN card, Last Pay Slip from the previous Employer before joining the duties.
- 7) You will produce 2 passport size recent photographs.
- 8) You are required to give the correct mailing address as soon as you join your duties. It will be presumed that any letter sent by Registered Post Acknowledgement Due (RPAD) or Speed Post or E-Mail on the address given, shall be deemed to have been acknowledged duly signed by you.
- 9) You are entitled Casual Leave as per Rules & Regulation of DYPEECT, subject to changes from time to time.
- 10) You are entitled for Medical Leave only after completion of one-year regular services and as per Rules & Regulation of DYPEECT, subject to changes from time to time.
- 11) If you want to leave the service during the tenure of your appointment, you will have to give one month's notice in writing to the Management. A sum equal to your one months' salary will be deducted or you will need to deposit the same amount to employer in case you resign without serving a one months' notice period. It is desirable that being a teaching faculty, you do not leave the job when the academic session is in progress.
- 12) You will submit to the office the medical fitness certificate from the Registered Medical panel appointed by the DYPEECT before joining your duties.

*Pooja D Shinde*  
28/8/2020

Page 1 of 2



- 13) You will not conduct or engage yourself in private tuitions or private coaching classes.
- 14) You will not engage yourself in any other paid job, full time, part time, honorary or otherwise during the continuance of your service in this Institute/College. You will not undertake any R & D or consultancy work and not register for any degree / diploma / certificate course without approval of the competent authority of the Trust.
- 15) You will not appear for any examinations/Admission without prior permission of the management in service.
- 16) You will not take any active part in the politics, neither involved directly or indirectly in illegal financial matters.
- 17) Your services are transferable within the trust organization only.
- 18) You will not directly or indirectly get yourself involved in any of the anti-activities against the management which may cause any harm to the institute/college or the management.
- 19) Your behavior with colleagues and entire institute/college staff should be polite, co-operative and gentle.
- 20) You will not form any union or organization amongst yourself and colleagues.
- 21) You will not process any letters either signed by you or signed jointly on any issues against the Management/Authorities without prior permission of the Principal/Director. Also, you will not approach to any authorities connected to the Institute/ College / Trust without prior permission of the Principal / Director.
- 22) You will put your grievances to the Management through Principal / Director only.
- 23) You will have to carry out the duties / work assigned to you by the Principal / Director and the Management besides your teaching work / routine work.
- 24) If you found absent continuously for more than 15 days without prior written permission from the Principal/Director, your services will stand terminated automatically and no further correspondence will be entertained thereafter.
- 25) Any information given in the application form if found incorrect contradictory at any time after the appointment, your services will be terminated forthwith, and no further correspondence will be entertained thereafter.
- 26) Progress Report: You will submit your academic progress report and other activities, seminars, presentation of papers, workshop, Self Appraisal etc. twice every year in the months of April and November.
- 27) If it is observed that your performance is not satisfactory / your behavior is not in the interest of the institute or College or trust / you commit breach of terms and conditions as mentioned in your appointment / you are found medically unfit (physically/mentally), your services shall be terminated without giving any notice period.
- 28) You will have to communicate your acceptance in writing to the Management/Director/Principal **within two weeks** from the date of receipt of Order of Appointment, failing which your appointment is liable to be withdrawal / cancelled. However, in case you need an extension of time limit for joining the duties you will have to apply in writing for grant of extension stating the reasons for the same and indicating the date on which you intend to join the duties. The request for grant of extension of time limit for joining the duties for the post shall be considered and you will be informed in the matter. The decision of the management of the **Dr. D Y Patil School of Engineering** shall be final.
- 29) If you are found guilty of violation of any terms & conditions mentioned above you will be liable for disciplinary action and punishment decided by the Management/Director/ Principal as provided in the Rules & Regulations.
- 30) In view of this appointment order, the previous appointment order/s stands cancelled.
- 31) Any dispute arises in the service will be dealt legally in jurisdiction of Pune City only.

*For Dr. D Y Patil Educational Enterprises Charitable Trust*

  
**Hrridaysh Deshpande**  
**Authorized Signatory**



**Copy to:**

- 1 Master File DYPEECT.
- 2 Principal, Dr. D Y Patil School of Engineering  
(Two Copies: [1] Personal File [2] Accounts Section).
- 3 Chief Financial Officer, DYPEECT.



## Dr D Y PATIL EDUCATIONAL ENTERPRISES CHARITABLE TRUST

Ref. ADYPKC/SOE/AO/T/PM/2020-21/ 2

Date: 10.08.2020

To,  
Mr. Prashant L Mandale  
Swami Vivekanand Nagar,  
Bhavsar Chowk,  
Taroda (Khu), Tal  
Dist- Nander  
Email- [Prashantmandale69@gmail.com](mailto:Prashantmandale69@gmail.com)  
Contact- 9096161484

### Appointment Order

Mr. Prashant L Mandale,

Following your application and subsequent interview for the post of **Assistant Professor**, I am pleased to inform you that the Management has appointed you as **Assistant Professor in Computer Engineering Department at Dr. D Y Patil School of Engineering**. The terms & conditions of the appointment are as follows.

- 1) Your services are governed by the Maharashtra Universities Act, statues, ordinances, rules & regulations, code of conduct, laid down by the Savitribai Phule Pune University, Government of Maharashtra and service rules of the Trust and will be responsible to the Principal/Director of the Institute for discharge of your duties.
- 2) Your appointment is on **purely temporary basis** for a period of **Academic Year 2020-21 (i.e. upto 31<sup>st</sup> May 2021 only)** from the date of joining i.e. 10<sup>th</sup> August 2020.
- 3) You will be paid consolidated monthly salary of **Rs. 35,000 Only (Rs Thirty Five Thousand Only)**. No other allowances will be admissible. The salary payment will be subject to statutory deduction of taxes as applicable.
- 4) Your appointment is subject to the minimum numbers of the students and the sufficient workload prescribed for the post.
- 5) Your appointment is on purely temporary basis and will automatically come to an end on the expiry of tenure and in any such event; you shall not claim any right to be continued in the services. You shall not claim to be a regular/permanent employee of the Institute/College. At any time during the tenure of your services or after termination thereof, in any manner whatsoever, and shall not claim automatic re-appointment to the said post after expiry of the tenure of your services and you will not be eligible for any retiral benefits.
- 6) You shall submit the certified true copies of relevant documents such as birth certificate, mark sheets, experience certificates, Approval Letters, reliving certificate, Aadhar Card, PAN card, Last Pay Slip from the previous Employer before joining the duties.
- 7) You will produce 2 passport size recent photographs.
- 8) You are required to give the correct mailing address as soon as you join your duties. It will be presumed that any letter sent by Registered Post Acknowledgement Due (RPAD) or Speed Post or E-Mail on the address given, shall be deemed to have been acknowledged duly signed by you.
- 9) You are entitled Casual Leave as per Rules & Regulation of DYPEECT, subject to changes from time to time.
- 10) You are entitled for Medical Leave only after completion of one-year regular services and as per Rules & Regulation of DYPEECT, subject to changes from time to time.
- 11) If you want to leave the service during the tenure of your appointment, you will have to give one month's notice in writing to the Management. A sum equal to your one months' salary will be deducted or you will need to deposit the same amount to employer in case you resign without serving a one months' notice period. It is desirable that being a teaching faculty, you do not leave the job when the academic session is in progress.
- 12) You will submit to the office the medical fitness certificate from the Registered Medical panel appointed by the DYPEECT before joining your duties.

Received  
*[Signature]*  
25/08/2020

Page 1 of 2

- 13) You will not conduct or engage yourself in private tuitions or private coaching classes.
- 14) You will not engage yourself in any other paid job, full time, part time, honorary or otherwise during the continuance of your service in this Institute/College. You will not undertake any R & D or consultancy work and not register for any degree / diploma / certificate course without approval of the competent authority of the Trust.
- 15) You will not appear for any examinations/Admission without prior permission of the management in service.
- 16) You will not take any active part in the politics, neither involved directly or indirectly in illegal financial matters.
- 17) Your services are transferable within the trust organization only.
- 18) You will not directly or indirectly get yourself involved in any of the anti-activities against the management which may cause any harm to the institute/college or the management.
- 19) Your behavior with colleagues and entire institute/college staff should be polite, co-operative and gentle.
- 20) You will not form any union or organization amongst yourself and colleagues.
- 21) You will not process any letters either signed by you or signed jointly on any issues against the Management/Authorities without prior permission of the Principal/Director. Also, you will not approach to any authorities connected to the Institute/ College / Trust without prior permission of the Principal / Director.
- 22) You will put your grievances to the Management through Principal / Director only.
- 23) You will have to carry out the duties / work assigned to you by the Principal / Director and the Management besides your teaching work / routine work.
- 24) If you found absent continuously for more than 15 days without prior written permission from the Principal/Director, your services will stand terminated automatically and no further correspondence will be entertained thereafter.
- 25) Any information given in the application form if found incorrect contradictory at any time after the appointment, your services will be terminated forthwith, and no further correspondence will be entertained thereafter.
- 26) Progress Report: You will submit your academic progress report and other activities, seminars, presentation of papers, workshop, Self Appraisal etc. twice every year in the months of April and November.
- 27) If it is observed that your performance is not satisfactory / your behavior is not in the interest of the institute or College or trust / you commit breach of terms and conditions as mentioned in your appointment / you are found medically unfit (physically/mentally), your services shall be terminated without giving any notice period.
- 28) You will have to communicate your acceptance in writing to the Management/Director/Principal **within two weeks** from the date of receipt of Order of Appointment, failing which your appointment is liable to be withdrawal / cancelled. However, in case you need an extension of time limit for joining the duties you will have to apply in writing for grant of extension stating the reasons for the same and indicating the date on which you intend to join the duties. The request for grant of extension of time limit for joining the duties for the post shall be considered and you will be informed in the matter. The decision of the management of the **Dr. D Y Patil School of Engineering** shall be final.
- 29) If you are found guilty of violation of any terms & conditions mentioned above you will be liable for disciplinary action and punishment decided by the Management/Director/ Principal as provided in the Rules & Regulations.
- 30) In view of this appointment order, the previous appointment order/s stands cancelled.
- 31) Any dispute arises in the service will be dealt legally in jurisdiction of Pune City only.

*For Dr. D Y Patil Educational Enterprises Charitable Trust*

*Hrridaysh*  
**Hrridaysh Deshpande**  
Authorized Signatory



**Copy to:**

- 1 Master File DYPECT.
- 2 Principal, Dr. D Y Patil School of Engineering  
(Two Copies: [1] Personal File [2] Accounts Section).
- 3 Chief Financial Officer, DYPECT.



**D Y PATIL GROUP**

Dr D Y PATIL GROUP OF INSTITUTIONS'S

Dr D Y PATIL TECHNICAL CAMPUS

**Dr D Y PATIL SCHOOL OF ENGINEERING**

No. DrDYPSOE/AL/JN/12092016

Date: 12/09/2016

**APPOINTMENT ORDER**

To:

**Ms Jagruti Ni mgulkar**

Pune.

E Mail: jagruti.nimgulkar@gmail.com

Mobile: +91 7066233908

Sub: Appointment to the Post of Assistant Professor, Department of Mechanical Engineering at Dr D Y Patil School of Engineering, Pune

Ma'm,

With reference to the subject mentioned above, we have pleasure to inform you that you are appointed as **Assistant Professor, Department of Mechanical Engineering** at Dr D Y Patil School of Engineering, Dr D Y Patil Knowledge City, Charholi Bk., Via Lohegaon, Pune 412 105. This appointment is subject to the following terms and conditions :

- 1) The appointment will be effective from the date of your joining the duties.
- 2) The appointment is on temporary ad-hoc basis. You will have to apply and appear for interview before a Selection Committee constituted as per norms of Pune University as and when the posts are advertised, for regularization of your appointment. The continuation of your appointment is subject to your performance, recommendations and decision of this committee.
- 3) You will be paid a monthly remuneration which includes basic pay of Rs 16900 (Rs Sixteen Thousand Nine Hundred only) plus Academic Grade Pay (AGP) of Rs. 6,000 (Rs Six Thousand) in Sixth Pay Commission Pay Band of Rs 15,600 - 39100 and other allowances as prescribed by the Trust from time to time. The personal pay to be adjusted in the event of increase of DA. The salary payments will be subject to deduction of statutory taxes as applicable.
- 4) You will have to perform duties as mentioned below:
  - a) To teach the subject/s assigned to you by the Principal/Director of the School (Theory as well as Practical) in accordance with the syllabus of the University.
  - b) To carry out any other duties as may be assigned to you from time to time by the Principal/Director of the School for smooth conduct of academic and allied co-curricular programmes and conduct of various institute and university examinations including assessment of papers.
  - c) To participate in various skill development /reorientation/ training programmes aimed at upgrading teaching capabilities of teaching faculty.

Received  
A. Patel  
19.10.16

Nimgulkar

- 5) For discharge of your duties you will be responsible to the Principal/ Director of the School of Engineering and subject the rules and regulations as laid down by the University, AICTE and State Government & Trust.
- 6) While joining the duties, you will have to submit two sets of certified true copies of documents in support of your qualifications, experience, discharge certificate from previous employer and three recent passport size photographs and execute an agreement as prescribed by the Trust.
- 7) You will be required to undergo medical examination before Medical Officer attached to the Dr D Y Patil Knowledge City Campus when medical check up of staff of the Institutions in the Dr D Y Patil Knowledge City Campus is organized.
- 8) You will have to submit your correct mailing address on joining the duties and also keep the Director of the School informed about subsequent changes, if there be any. The communication sent by the institute by RPAD on the address given by you shall be deemed to have been received and acknowledged by you.
- 9) You will not conduct or engage yourself in any private tuitions or private coaching classes., will not engage yourself in any other job, paid or honorary, full time or part time while in the service of the this institute.
- 10) Your services are transferable to any other institute run by D Y Patil Group.
- 11) You will have to give one months' notice or pay/forgo one month's salary in lieu of the notice period while resigning the job. It is desirable that being a teaching faculty, you do not leave the job when the teaching session is in progress.
- 12) a) If it is observed that your performance is not satisfactory /your behavior is not in the interest of the institute/trust/ you commit breach of the terms and conditions governing your appointment/you are found medically unfit (physically/mentally), your services shall be terminated without giving any notice period.  
b) Your continuous unauthorized absence from duty for more than fifteen days shall lead to automatic termination of your services from the date from which you remain absent.  
c) If you are not selected and recommended for regularization by the Selection Committee constituted as per norms of the University, your services shall terminated with effect from the date on which the candidate selected by the said committee reports for duty.

**Yours faithfully,  
For Dr D Y Patil School of Engineering**



**Prof B G Bhandarkar  
Director Corporate Relations  
Authorised Signatory**

Copy to

1. Principal/Director Dr D Y Patil School of Engineering  
[2 copies 1. Personal File 2. Accounts Section]
2. Chief Financial Officer Head Office
3. DYPEECT Master File



**Dr D Y PATIL GROUP**  
Dr D Y PATIL GROUP OF INSTITUTIONS'S  
Dr D Y PATIL TECHNICAL CAMPUS

## Dr D Y PATIL SCHOOL OF ENGINEERING

No. DrDYP SOE/AL/PK/20072016

Date: 20/07/2016

### APPOINTMENT ORDER

To:

**Mr Prashant Karajagi**

Flat No 102, Bldg C Pavani Pride,  
Sector 32, Ravet Pradhikaran ,Pune  
Mobile:+91 9921029913

Sub: Appointment to the Post of Assistant Professor, Department of Mechanical Engineering  
at Dr D Y Patil School of Engineering, Pune

Sir,

With reference to the subject mentioned above, we have pleasure to inform you that you are appointed as **Assistant Professor, Department of Mechanical Engineering** at Dr D Y Patil School of Engineering, Dr D Y Patil Knowledge City, Charholi Bk., Via Lohegaon, Pune 412 105. This appointment is subject to the following terms and conditions :

- 1) The appointment will be effective from the date of your joining the duties.
- 2) The appointment is on temporary ad-hoc basis. You will have to apply and appear for interview before a Selection Committee constituted as per norms of Pune University as and when the posts are advertised, for regularization of your appointment. The continuation of your appointment is subject to your performance, recommendations and decision of this committee.
- 3) You will be paid a monthly remuneration which includes basic pay of Rs 29250 (Rs Twenty Nine Thousand Two Hundred and Fifty only) plus Academic Grade Pay (AGP) of Rs. 6,000 (Rs Six Thousand) and plus ~~special~~ pay of Rs 10000 (Rs Ten Thousand only) in Sixth Pay Commission Pay Band of Rs 15600 - 39100 and other allowances as prescribed by the Trust from time to time. The salary payments will be subject to deduction of statutory taxes as applicable. *The personal pay is subject to adjustment in the event of increase in DA.*
- 4) You will have to perform duties as mentioned below:
  - a) To teach the subject/s assigned to you by the Principal/Director of the School (Theory as well as Practical) in accordance with the syllabus of the University.
  - b) To carry out any other duties as may be assigned to you from time to time by the Principal/Director of the School for smooth conduct of academic and allied co-curricular programmes and conduct of various institute and university examinations including assessment of papers.
  - c) To participate in various skill development /reorientation/ training programmes aimed at upgrading teaching capabilities of teaching faculty.

*received  
Prashant Karajagi  
3/8/16*

- 5) For discharge of your duties you will be responsible to the Principal/ Director of the School of Engineering and subject the rules and regulations as laid down by the University, AICTE and State Government & Trust.
- 6) While joining the duties, you will have to submit two sets of certified true copies of documents in support of your qualifications, experience, discharge certificate from previous employer and three recent passport size photographs and execute an agreement as prescribed by the Trust.
- 7) You will be required to undergo medical examination before Medical Officer attached to the Dr D Y Patil Knowledge City Campus when medical check up of staff of the Institutions in the Dr D Y Patil Knowledge City Campus is organized.
- 8) You will have to submit your correct mailing address on joining the duties and also keep the Director of the School informed about subsequent changes, if there be any. The communication sent by the institute by RPAD on the address given by you shall be deemed to have been received and acknowledged by you.
- 9) You will not conduct or engage yourself in any private tuitions or private coaching classes., will not engage yourself in any other job, paid or honorary, full time or part time while in the service of the this institute.
- 10) Your services are transferable to any other institute run by D Y Patil Group.
- 11) You will have to give one months' notice or pay/forgo one month's salary in lieu of the notice period while resigning the job. It is desirable that being a teaching faculty, you do not leave the job when the teaching session is in progress.
- 12) a) If it is observed that your performance is not satisfactory /your behavior is not in the interest of the institute/trust/ you commit breach of the terms and conditions governing your appointment/you are found medically unfit (physically/mentally), your services shall be terminated without giving any notice period.  
b) Your continuous unauthorized absence from duty for more than fifteen days shall lead to automatic termination of your services from the date from which you remain absent.  
c) If you are not selected and recommended for regularization by the Selection Committee constituted as per norms of the University, your services shall terminated with effect from the date on which the candidate selected by the said committee reports for duty.

**Yours faithfully,  
For Dr D Y Patil School of Engineering**

  
**Prof B G Bhandarkar  
Director Corporate Relations  
Authorised Signatory**

Copy to

1. Principal/Director Dr D Y Patil School of Engineering  
[2 copies 1. Personal File 2. Accounts Section  
2. Chief Financial Officer Head Office  
3. DYPEECT Master File



**D Y PATIL GROUP**  
Dr D Y PATIL GROUP OF INSTITUTIONS'S  
Dr D Y PATIL TECHNICAL CAMPUS  
**Dr D Y PATIL SCHOOL OF ENGINEERING**

No. DrDYPSOE/AL/YSD/27012016

Date: 27/01/2016

**APPOINTMENT ORDER**

To:

**Mr Kolekar Umaji Narayan**

E Mail: umaji.kolekar007@gmail.com

Mobile: +91 9975937373

Sub: Appointment to the Post of Assistant Professor, Department of Mechanical Engineering at Dr D Y Patil School of Engineering, Pune

Sir,

With reference to the subject mentioned above, we have pleasure to inform you that you are appointed as **Assistant Professor, Department of Mechanical Engineering** at Dr D Y Patil School of Engineering, Dr D Y Patil Knowledge City, Charholi Bk., Via Lohegaon, Pune 412 105. This appointment is subject to the following terms and conditions :

- 1) The appointment will be effective from the date of your joining the duties.
- 2) The appointment is on temporary ad-hoc basis. You will have to apply and appear for interview before a Selection Committee constituted as per norms of Pune University as and when the posts are advertised, for regularization of your appointment. The continuation of your appointment is subject to your performance, recommendations and decision of this committee.
- 3) You will be paid a monthly remuneration which includes basic pay of Rs 17550 (Rs Seventeen thousand five hundred and fifty only) plus Academic Grade Pay (AGP) of Rs. 6,000 (Rs Six Thousand) in Sixth Pay Commission Pay Band of Rs 15600 - 39100 and other allowances as prescribed by the Trust from time to time. The salary payments will be subject to deduction of statutory taxes as applicable.
- 4) You will have to perform duties as mentioned below:
  - a) To teach the subject/s assigned to you by the Principal/Director of the School (Theory as well as Practical) in accordance with the syllabus of the University.
  - b) To carry out any other duties as may be assigned to you from time to time by the Principal/Director of the School for smooth conduct of academic and allied co-curricular programmes and conduct of various institute and university examinations including assessment of papers.
  - c) To participate in various skill development /reorientation/ training programmes aimed at upgrading teaching capabilities of teaching faculty.

*Received*  
*17/02/2016*

*Received*  
*Upotelcar*  
*24.2.2016*



- 5) For discharge of your duties you will be responsible to the Principal/ Director of the School of Engineering and subject the rules and regulations as laid down by the University, AICTE and State Government & Trust.
- 6) While joining the duties, you will have to submit two sets of certified true copies of documents in support of your qualifications, experience, discharge certificate from previous employer and three recent passport size photographs and execute an agreement as prescribed by the Trust.
- 7) You will be required to undergo medical examination before Medical Officer attached to the Dr D Y Patil Knowledge City Campus when medical check up of staff of the Institutions in the Dr D Y Patil Knowledge City Campus is organized.
- 8) You will have to submit your correct mailing address on joining the duties and also keep the Director of the School informed about subsequent changes, if there be any. The communication sent by the institute by RPAD on the address given by you shall be deemed to have been received and acknowledged by you.
- 9) You will not conduct or engage yourself in any private tuitions or private coaching classes., will not engage yourself in any other job, paid or honorary, full time or part time while in the service of the this institute.
- 10) Your services are transferable to any other institute run by D Y Patil Group.
- 11) You will have to give three months' notice or pay/forgo three month's salary in lieu of the notice period while resigning the job. It is desirable that being a teaching faculty, you do not leave the job when the teaching session is in progress.
- 12) a) If it is observed that your performance is not satisfactory /your behavior is not in the interest of the institute/trust/ you commit breach of the terms and conditions governing your appointment/you are found medically unfit (physically/mentally), your services shall be terminated without giving any notice period.  
b) Your continuous unauthorized absence from duty for more than fifteen days shall lead to automatic termination of your services from the date from which you remain absent.  
c) If you are not selected and recommended for regularization by the Selection Committee constituted as per norms of the University, your services shall terminated with effect from the date on which the candidate selected by the said committee reports for duty.

**Yours faithfully,  
For Dr D Y Patil School of Engineering**

  
**Prof B G Bhandarkar  
Director Corporate Relations  
Authorised Signatory**

Copy to

1. Principal/Director Dr D Y Patil School of Engineering  
[2 copies 1. Personal File 2. Accounts Section]
2. Chief Financial Officer Head Office
3. DYPEECT Master File



**D Y PATIL GROUP**

Dr D Y PATIL GROUP OF INSTITUTIONS'S

Dr D Y PATIL TECHNICAL CAMPUS

## **Dr D Y PATIL SCHOOL OF ENGINEERING**

No. DrDYP SOE/AL/YSD/13012016

Date: 13/01/2016

### **APPOINTMENT ORDER**

To:

**Mr Yogesh Shankarrao Danekar**

E Mail: [danekaryogesh@gmail.com](mailto:danekaryogesh@gmail.com)

Mobile: +91 9975618189

Sub: Appointment to the Post of Assistant Professor, Department of Mechanical Engineering at Dr D Y Patil School of Engineering, Pune

Sir,

With reference to the subject mentioned above, we have pleasure to inform you that you are appointed as **Assistant Professor, Department of Mechanical Engineering** at Dr D Y Patil School of Engineering, Dr D Y Patil Knowledge City, Charholi Bk., Via Lohegaon, Pune 412 105. This appointment is subject to the following terms and conditions :

- 1) The appointment will be effective from the date of your joining the duties.
- 2) The appointment is on temporary ad-hoc basis. You will have to apply and appear for interview before a Selection Committee constituted as per norms of Pune University as and when the posts are advertised, for regularization of your appointment. The continuation of your appointment is subject to your performance, recommendations and decision of this committee.
- 3) You will be paid a monthly remuneration which includes basic pay of Rs 17500 (Rs Seventeen thousand five hundred only) in Sixth Pay Commission Pay Band of Rs 15600 - 39100 and plus special pay of Rs 3000 (Rs Three Thousand only) other allowances as prescribed by the Trust from time to time. The salary payments will be subject to deduction of statutory taxes as applicable.
- 4) You will have to perform duties as mentioned below:
  - a) To teach the subject/s assigned to you by the Principal/Director of the School (Theory as well as Practical) in accordance with the syllabus of the University.
  - b) To carry out any other duties as may be assigned to you from time to time by the Principal/Director of the School for smooth conduct of academic and allied co-curricular programmes and conduct of various institute and university examinations including assessment of papers.
  - c) To participate in various skill development /reorientation/ training programmes aimed at upgrading teaching capabilities of teaching faculty.

*Y. S. Danekar*  
*Received*  
*Spotekar*  
*21.1.2016*

- 5) For discharge of your duties you will be responsible to the Principal/ Director of the School of Engineering and subject the rules and regulations as laid down by the University, AICTE and State Government & Trust.
- 6) While joining the duties, you will have to submit two sets of certified true copies of documents in support of your qualifications, experience, discharge certificate from previous employer and three recent passport size photographs and execute an agreement as prescribed by the Trust.
- 7) You will be required to undergo medical examination before Medical Officer attached to the Dr D Y Patil Knowledge City Campus when medical check up of staff of the Institutions in the Dr D Y Patil Knowledge City Campus is organized.
- 8) You will have to submit your correct mailing address on joining the duties and also keep the Director of the School informed about subsequent changes, if there be any. The communication sent by the institute by RPAD on the address given by you shall be deemed to have been received and acknowledged by you.
- 9) You will not conduct or engage yourself in any private tuitions or private coaching classes., will not engage yourself in any other job, paid or honorary, full time or part time while in the service of the this institute.
- 10) Your services are transferable to any other institute run by D Y Patil Group.
- 11) You will have to give three months' notice or pay/forgo three month's salary in lieu of the notice period while resigning the job. It is desirable that being a teaching faculty, you do not leave the job when the teaching session is in progress.
- 12) a) If it is observed that your performance is not satisfactory /your behavior is not in the interest of the institute/trust/ you commit breach of the terms and conditions governing your appointment/you are found medically unfit (physically/mentally), your services shall be terminated without giving any notice period.  
b) Your continuous unauthorized absence from duty for more than fifteen days shall lead to automatic termination of your services from the date from which you remain absent.  
c) If you are not selected and recommended for regularization by the Selection Committee constituted as per norms of the University, your services shall terminated with effect from the date on which the candidate selected by the said committee reports for duty.

**Yours faithfully,  
For Dr D Y Patil School of Engineering**

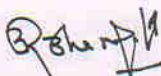
  
**Prof B G Bhandarkar  
Director Corporate Relations  
Authorised Signatory**

Copy to

1. Principal/Director Dr D Y Patil School of Engineering  
[2 copies 1. Personal File 2. Accounts Section]
2. Chief Financial Officer Head Office
3. DYPEECT Master File



**D Y PATIL GROUP**

Dr D Y PATIL GROUP OF INSTITUTIONS'S

Dr D Y PATIL TECHNICAL CAMPUS

**Dr D Y PATIL SCHOOL OF ENGINEERING**

No. DrDYPSOE/AL/PBM/15012016

Date: 15/01/2016

**APPOINTMENT ORDER**

To:

**Mr Parag Bhapu Marathe**

Email: parag.marathe8@gmail.com

Mobile:+91 9975618189

Sub: Appointment to the Post of Assistant Professor, Department of Mechanical Engineering at Dr D Y Patil School of Engineering, Pune

Sir,

With reference to the subject mentioned above, we have pleasure to inform you that you are appointed as **Assistant Professor, Department of Mechanical Engineering** at Dr D Y Patil School of Engineering, Dr D Y Patil Knowledge City, Charholi Bk., Via Lohegaon, Pune 412 105. This appointment is subject to the following terms and conditions :

- 1) The appointment will be effective from the date of your joining the duties.
- 2) The appointment is on temporary ad-hoc basis. You will have to apply and appear for interview before a Selection Committee constituted as per norms of Pune University as and when the posts are advertised, for regularization of your appointment. The continuation of your appointment is subject to your performance, recommendations and decision of this committee.
- 3) You will be paid a monthly remuneration which includes basic pay of Rs 17550 (Rs Seventeen thousand five hundred and fifty only) in Sixth Pay Commission Pay Band of Rs 15600 - 39100 and other allowances as prescribed by the Trust from time to time. The salary payments will be subject to deduction of statutory taxes as applicable.
- 4) You will have to perform duties as mentioned below:
  - a) To teach the subject/s assigned to you by the Principal/Director of the School (Theory as well as Practical) in accordance with the syllabus of the University.
  - b) To carry out any other duties as may be assigned to you from time to time by the Principal/Director of the School for smooth conduct of academic and allied co-curricular programmes and conduct of various institute and university examinations including assessment of papers.
  - c) To participate in various skill development /reorientation/ training programmes aimed at upgrading teaching capabilities of teaching faculty.

*Dr. D. Y. Patil*  
25/1/16

*Spotelcar*  
27.1.2016

- 5) For discharge of your duties you will be responsible to the Principal/ Director of the School of Engineering and subject the rules and regulations as laid down by the University, AICTE and State Government & Trust.
- 6) While joining the duties, you will have to submit two sets of certified true copies of documents in support of your qualifications, experience, discharge certificate from previous employer and three recent passport size photographs and execute an agreement as prescribed by the Trust.
- 7) You will be required to undergo medical examination before Medical Officer attached to the Dr D Y Patil Knowledge City Campus when medical check up of staff of the Institutions in the Dr D Y Patil Knowledge City Campus is organized.
- 8) You will have to submit your correct mailing address on joining the duties and also keep the Director of the School informed about subsequent changes, if there be any. The communication sent by the institute by RPAD on the address given by you shall be deemed to have been received and acknowledged by you.
- 9) You will not conduct or engage yourself in any private tuitions or private coaching classes., will not engage yourself in any other job, paid or honorary, full time or part time while in the service of the this institute.
- 10) Your services are transferable to any other institute run by D Y Patil Group.
- 11) You will have to give three months' notice or pay/forgo three month's salary in lieu of the notice period while resigning the job. It is desirable that being a teaching faculty, you do not leave the job when the teaching session is in progress.
- 12) a) If it is observed that your performance is not satisfactory /your behavior is not in the interest of the institute/trust/ you commit breach of the terms and conditions governing your appointment/you are found medically unfit (physically/mentally), your services shall be terminated without giving any notice period.  
b) Your continuous unauthorized absence from duty for more than fifteen days shall lead to automatic termination of your services from the date from which you remain absent.  
c) If you are not selected and recommended for regularization by the Selection Committee constituted as per norms of the University, your services shall terminated with effect from the date on which the candidate selected by the said committee reports for duty.

**Yours faithfully,  
For Dr D Y Patil School of Engineering**

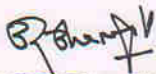

**Prof B G Bhandarkar  
Director Corporate Relations  
Authorised Signatory**

Copy to

1. Principal/Director Dr D Y Patil School of Engineering  
[2 copies 1. Personal File 2. Accounts Section]
2. Chief Financial Officer Head Office
3. DYPEECT Master File



**D Y PATIL GROUP**

DR D Y PATIL GROUP OF INSTITUTION'S  
DR D Y PATIL TECHNICAL CAMPUS

## **Dr D Y PATIL SCHOOL OF ENGINEERING**

No.DrDYPSOE/DM/22062015

Date: 22/06/2015

### **APPOINTMENT ORDER**

To:  
Dr Dileep More  
**E Mail:** dileep.more@gmail.com  
**Mobile:** +91 9226967072

**Sub:** Appointment to the Post of Associate Professor in Department of Mechanical Engineering at Dr D Y Patil School of Engineering, Pune

Sir,

With reference to the subject mentioned above, we have pleasure to inform you that you are appointed as **Associate Professor in Department of Mechanical Engineering** at Dr D Y Patil School of Engineering at Dr D Y Patil Knowledge City, Charholi Bk., Via Lohegaon, Pune 412 105. This appointment is subject to the following terms and conditions:

- 1) The appointment will be effective from the date of your joining the duties.
- 2) The appointment is on temporary ad-hoc basis. You will have to apply and appear for interview before a Selection Committee constituted as per norms of Pune University as and when the posts are advertised, for regularization of your appointment. The continuation of your appointment is subject to your performance, recommendations and decision of this committee.
- 3) You will be paid consolidated monthly salary of Rs 1,20,000 (Rs One lakh Twenty Thousand Only). No other allowances will be admissible. The salary payment will be subject to statutory deduction of taxes as applicable.
- 4) You will have to perform duties as mentioned below
  - a) To teach the subject/s assigned to you by the Principal/Director of the School (Theory as well as Practical) in accordance with the syllabus of the University.
  - b) To carry out any other duties as may be assigned to you from time to time by the Principal/Director of the School for smooth conduct of academic and allied co-curricular programmes and conduct of various institute and university examinations including assessment of papers.
  - c) To participate in various skill development /reorientation / training programmes aimed at upgrading teaching capabilities of teaching faculty.

- 5) For discharge of your duties you will be responsible to the Principal/ Director of the School of Engineering and subject the rules and regulations as laid down by the University, AICTE and State Government & Trust.
- 6) While joining the duties, you will have to submit two sets of certified true copies of documents in support of your qualifications, experience, discharge certificate from previous employer and three recent passport size photographs and execute an agreement as prescribed by the Trust.
- 7) You will be required to undergo medical examination before Medical Officer attached to the Dr D Y Patil Knowledge City Campus when medical check up of staff of the Institutions in the Dr D Y Patil Knowledge City Campus is organized.
- 8) You will have to submit your correct mailing address on joining the duties and also keep the Director of the School informed about subsequent changes, if there be any. The communication sent by the institute by RPAD on the address given by you shall be deemed to have been received and acknowledged by you.
- 9) You will not conduct or engage yourself in any private tuitions or private coaching classes., will not engage yourself in any other job, paid or honorary, full time or part time while in the service of the this institute.
- 10) Your services are transferable to any other institute run by D Y Patil Group.
- 11) You will have to give three months' notice or pay/forgo three month's salary in lieu of the notice period while resigning the job. It is desirable that being a teaching faculty, you do not leave the job when the teaching session is in progress.
- 12) a) If it is observed that your performance is not satisfactory /your behavior is not in the interest of the institute/trust/ you commit breach of the terms and conditions governing your appointment/you are found medically unfit (physically/mentally), your services shall be terminated without giving any notice period.  
b) Your continuous unauthorized absence from duty for more than fifteen days shall lead to automatic termination of your services from the date from which you remain absent.  
c) If you are not selected and recommended for regularization by the Selection Committee constituted as per norms of the University, your services shall terminated with effect from the date on which the candidate selected by the said committee reports for duty.

Yours faithfully,

**For Dr D Y Patil School of Engineering**



**Prof B G Bhandarkar**  
**Director Corporate Relations**  
**Authorised Signatory**

Copy to

1. Principal/Director Dr D Y Patil School of Engineering  
[2 copies 1. Personal File 2. Accounts Section]
2. Chief Financial Officer Head Office
3. DYPECT Master File



**D Y PATIL GROUP**

DR D Y PATIL GROUP OF INSTITUTION'S  
DR D Y PATIL TECHNICAL CAMPUS

**Dr D Y PATIL SCHOOL OF ENGINEERING**

No. DrDYP SOE/AL/GVM/01062015

Date: 01/06/2015

**APPOINTMENT ORDER**

To:

**Mr Ghule Vikram M**

E Mail: ravikantchoubey@gmail.com

Mobile: +91 8275757255

Sub: Appointment to the Post of Assistant Professor, Department of Mechanical Engineering at Dr D Y Patil School of Engineering, Pune

Sir,

With reference to the subject mentioned above, we have pleasure to inform you that you are appointed as **Assistant Professor, Department of Mechanical Engineering** at Dr D Y Patil School of Engineering, Dr D Y Patil Knowledge City, Charholi Bk., Via Lohegaon, Pune 412 105. This appointment is subject to the following terms and conditions :

- 1) The appointment will be effective from the date of your joining the duties.
- 2) The appointment is on temporary ad-hoc basis. You will have to apply and appear for interview before a Selection Committee constituted as per norms of Pune University as and when the posts are advertised, for regularization of your appointment. The continuation of your appointment is subject to your performance, recommendations and decision of this committee.
- 3) You will be paid a monthly remuneration which includes basic pay of Rs 18200 (Rs Eighteen Thousand Two hundred only) plus Academic Grade Pay (AGP) of Rs. 6,000 (Rs Six Thousand) in Sixth Pay Commission Pay Band of Rs 15,600 - 39100 plus personal pay of Rs 8000 (Rs Eight Thousand) and other allowances as prescribed by the Trust from time to time. The personal pay to be adjusted in the event of increase of DA. The salary payments will be subject to deduction of statutory taxes as applicable.
- 4) You will have to perform duties as mentioned below:
  - a) To teach the subject/s assigned to you by the Principal/Director of the School (Theory as well as Practical) in accordance with the syllabus of the University.
  - b) To carry out any other duties as may be assigned to you from time to time by the Principal/Director of the School for smooth conduct of academic and allied co-curricular programmes and conduct of various institute and university examinations including assessment of papers.
  - c) To participate in various skill development /reorientation/ training programmes aimed at upgrading teaching capabilities of teaching faculty.

Received  
G. Patil  
11/7/2015

*[Signature]*





old X

## DR D Y PATIL EDUCATIONAL ENTERPRISES CHARITABLE TRUST

Dr. D. Y. Patil Knowledge City, Charholi Bk, Via Lohegaon, Pune 412 105

[Mumbai Public Trust Registration No.E 4417 Pune : 11.10.2005]

Phone (020) 3061 2700 • Fax (020) 3061 2718

No.DrDYPEECT/SoE/APP/1129

Date: 25.7.2011

### D.Y.PATIL GROUP OF INSTITUTIONS APPOINTMENT ORDER

To:

**Shri.Amol Gaikawad**

Sub : Appointment to the Post of **Lecturer in Mechanical I Engineering**  
at Dr.D.Y.Patil School of Engineering Pune

Sir,

With reference to the subject mentioned above, we have pleasure to inform you that you are appointed as **Lecturer in Mechanical Engineering** at Dr.D.Y.Patil School of Engineering at Dr.D.Y.Patil Knowledge City, Charholi Bk.,Via Lohegaon, Pune 412 105.This appointment is subject to the following terms and conditions :

- 1) The appointment will be effective from the date of your joining the duties .
- 2) The appointment is on ad-hoc basis .You will have to apply and appear for interview before a Selection Committee constituted as per norms of Pune University as and when the posts are advertised, for regularization of your appointment. The continuation of your appointment is subject to your performance and recommendations & decision of this committee.
- 3) You will be paid consolidated salary of Rs.25000/- (Rs.Twenty five thousand only ) per month.No other allowances will be admissible. The salary payments will be subject to deduction of statutory taxes as applicable.
- 4) You will have to perform duties as mentioned below :
  - a) To teach the subject/s assigned to you by Head of Department/ Director of the Institute ( theory as well as practicals ) in accordance with the syllabus of the University .
  - b) To carry out any other duties as may be assigned to you from time to time by Head of Department/Head of Institute for smooth conduct of academic and allied co-curriculum programmes as well as conduct of various institute and university examinations.
  - f) To participate in various skill development /reorientation / training programmes aimed at upgrading teaching capabilities of teaching faculty.
- 5) For discharge of your duties you will be responsible to the Director of the School of Engineering and subject to the rules and regulations as laid down by the University, AICTE and State Government.

Received original  
AB Gaikwad

- 6) While joining the duties, you will have to submit two sets of certified true copies of documents in support of your qualifications , experience, discharge certificate from previous employer and three recent passport size photographs and execute an agreement as prescribed by the Trust.
- 7) You will be required to undergo medical examination before Medical Officer attached to the Integrated Campus when medical check up of staff of the Institutions under Technical Campus is organized .
- 8) You will have to submit your correct mailing address on joining he duties and also keep the Director of the institute informed about subsequent changes, if there be any.The communication sent by the institute by RPAD on the address given by you shall be deemed to have been received and acknowledged by you.
- 9) You will not conduct or engage yourself in any private tuitions or private coaching classes., will not engage yourself in any other job, paid or honorary, full time or part time while in the service of the this institute.
- 10) Your services are transferable to any other institute run by D.Y.Patil Group.
- 11) You will have to give one month's notice or pay/forgo one month's salary in lieu of the notice period while resigning the job.It is desirable that being a teaching faculty , you do not leave the job when the teaching session is in progress.
- 12) a) If it is observed that your performance is not satisfactory /your behaviour is not in the interest of the institute/trust/ you commit breach of the terms and conditions governing your appointment/you are found medically unfit (physically/mentally) ,your services shall be terminated without giving any notice period.  
b) Your continuous unauthorized absence from duty for more than fifteen days shall lead to automatic termination of your services from the date from which you remain absent.  
c) If you are not selected and recommended for regularization by the Selection Committee constituted as per norms of the University, your services shall terminated with effect from the date on which the candidate selected by the said committee reports for duty.

Yours faithfully,

**For Dr.D.Y.Patil Educational Enterprises Charitable Trust**

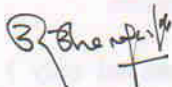

**Prof.B.G.Bhandarkar**  
**Director Corporate Relations**  
**Authorised Signatory**

Copy to

- 1 Director Dr.D.Y.Patil School of Engineering  
[ 2 copies ✓ 1 .Personal File 2.Accounts Section ]
- 2 Chief Financial Officer Head office
- 3 DYPEECT Master File



**D Y PATIL GROUP**

**Dr D Y PATIL EDUCATIONAL ENTERPRISES CHARITABLE TRUST**

No.DrDYPEECT/IC/APP/SoE/ 12-079

Date : 20.7.2012

**APPOINTMENT ORDER**

To:

**Shri.Sachin Jadhav**

Mobile : +91 99701 28311

E Mail : sachinjadv67@gmail.com

**Sub : Appointment to the Post of Lecturer in Mechanical Engineering**  
at Dr.D.Y.Patil School of Engineering ,Pune

Sir,

With reference to the subject mentioned above, we have pleasure to inform you that you are appointed as **Lecturer in Mechanical Engineering** at Dr.D.Y.Patil School of Engineering at Dr.D.Y.Patil Knowledge City, Charholi Bk., Via Lohegaon, Pune 412 105. This appointment is subject to the following terms and conditions :

- 1) The appointment will be effective from the date of your joining the duties .
- 2) The appointment is on temporary ad-hoc basis .You will have to apply and appear for interview before a Selection Committee constituted as per norms of Pune University as and when the posts are advertised, for regularization of your appointment. The continuation of your appointment is subject to your performance , recommendations and decision of this committee.
- 3) You will be paid basic salary of Rs.8,000/-(Rs. Eight thousand only ) in the pay scale of Rs.8,000-275-13,500 and other allowances as prescribed by the Trust from time to time.The salary payments will be subject to deduction of statutory taxes as applicable.
- 4) You will have to perform duties as mentioned below
  - a) To teach the subject/s assigned to you by the Director of the School (Theory as well as Practicals ) in accordance with the syllabus of the University.
  - b) To carry out any other duties as may be assigned to you from time to time by the Director of the School for smooth conduct of academic and allied co-curricular programmes and conduct of various institute and university examinations including assessment of papers.
  - c) To participate in various skill development /reorientation / training programmes aimed at upgrading teaching capabilities of teaching faculty.
- 5) For discharge of your duties you will be responsible to the Director of the School of Engineering and subject to the rules and regulations as laid down by the University, AICTE and State Government.

Received  
@Jadhav  
20/7/12

- 6) While joining the duties, you will have to submit two sets of certified true copies of documents in support of your qualifications , experience, discharge certificate from previous employer and three recent passport size photographs and execute an agreement as prescribed by the Trust..
- 7) You will be required to undergo medical examination before Medical Officer attached to the Technical Campus when medical check up of staff of the Institutions under Technical Campus is organized .
- 8) You will have to submit your correct mailing address on joining he duties and also keep the Director of the School informed about subsequent changes, if there be any. The communication sent by the institute by RPAD on the address given by you shall be deemed to have been received and acknowledged by you.
- 9) You will not conduct or engage yourself in any private tuitions or private coaching classes., will not engage yourself in any other job, paid or honorary, full time or part time while in the service of the this institute.
- 10) Your services are transferable to any other institute run by D.Y.Patil Group.
- 11) You will have to give one month's notice or pay/forgo one month's salary in lieu of the notice period while resigning the job.It is desirable that being a teaching faculty , you do not leave the job when the teaching session is in progress.
- 12) a) If it is observed that your performance is not satisfactory /your behaviour is not in the interest of the institute/trust/ you commit breach of the terms and conditions governing your appointment/you are found medically unfit (physically/mentally) ,your services shall be terminated without giving any notice period.  
b) Your continuous unauthorized absence from duty for more than fifteen days shall lead to automatic termination of your services from the date from which you remain absent.  
c) If you are not selected and recommended for regularization by the Selection Committee constituted as per norms of the University, your services shall terminated with effect from the date on which the candidate selected by the said committee reports for duty.

Yours faithfully,

**For Dr.D.Y.Patil Educational Enterprises Charitable Trust**

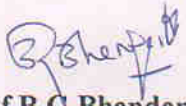
  
**Prof.B.G.Bhandarkar**  
**Director Corporate Relations**  
**Authorised Signatory**

Copy to

- 1 Director Dr.D.Y.Patil School of Engineering  
[ 2 copies 1 Personal File 2.Accounts Section ]
- 2 Chief Financial Officer Head office
- 3 DYPEECT Master File

Received  
By 26/11/12



**D Y PATIL GROUP**  
**Dr D Y PATIL EDUCATIONAL ENTERPRISES CHARITABLE TRUST**

No.DrDYPEECT/IC/APP/SoE/15-023

Date : 16.2.2015

**APPOINTMENT ORDER**

To:

**Mr. Santosh B.Jadhav**

**E Mail : hisantosh2007@rediffmail.com**

**Mobile : +91 96658 59537**

**Sub : Appointment to the Post of Asstt Prof of Mechanical Engineering at Dr.D.Y.Patil School of Engineering Pune**

Sir ,

With reference to the subject mentioned above, we have pleasure to inform you that you are appointed as **Asstt. Professor of Mechanical Engineering Engineering** at Dr.D.Y.Patil School of Engineering at Dr.D.Y.Patil Knowledge City, Charholi Bk., Via Lohegaon, Pune 412 105. This appointment is subject to the following terms and conditions :

- 1) The appointment will be effective from the date of your joining the duties .
- 2) The appointment is on temporary ad-hoc basis .You will have to apply and appear for interview before a Selection Committee constituted as per norms of Pune University as and when the posts are advertised, for regularization of your appointment. The continuation of your appointment is subject to your performance , recommendations and decision of this committee.
- 3) You will be paid basic pay of Rs 35,750/- ( Rs. Thirty five thousand & seven hundred fifty only ) plus Academic Grade Pay (AGP) of Rs. 6000/- ( Rs. Six thousand only ) per month in Sixth Pay Commission Pay Band of Rs.15600-39100 and other allowances as prescribed by the Trust from time to time. In addition to this you will be entitled to personal pay of Rs.5000/- (Rs.Four thousand only ) per month which will be suitably adjusted in the event of increase in DA. The salary payments will be subject to deduction of statutory taxes as applicable.
- 4) You will have to perform duties as mentioned below
  - a) To teach the subject/s assigned to you by the Principal/Director of the School (Theory as well as Practicals ) in accordance with the syllabus of the University.
  - b) To carry out any other duties as may be assigned to you from time to time by the Principal/Director of the School for smooth conduct of academic and allied co-curricular programmes and conduct of various institute and university examinations including assessment of papers.
  - c) To participate in various skill development /reorientation / training programmes aimed at upgrading teaching capabilities of teaching faculty.
- 5) For discharge of your duties you will be responsible to the Principal/ Director of the School of Engineering and subject the rules and regulations as laid down by the University, AICTE and State Government & Trust .
- 6) While joining the duties, you will have to submit two sets of certified true copies of documents in support of your qualifications , experience, discharge certificate from previous employer and three recent passport size photographs and execute an agreement as prescribed by the Trust..

Received  
Gmpatel  
18/3/2015

Received  
Gadgaonkar  
18-03-2015

- 7) You will be required to undergo medical examination before Medical Officer attached to the .Dr.D.Y.Patil Knowledge City Campus when medical check up of staff of the Institutions in the Dr.D.Y.Patil Knowledge City Campus is organized .
- 8) You will have to submit your correct mailing address on joining he duties and also keep the Director of the School informed about subsequent changes, if there be any. The communication sent by the institute by RPAD on the address given by you shall be deemed to have been received and acknowledged by you.
- 9) You will not conduct or engage yourself in any private tuitions or private coaching classes., will not engage yourself in any other job, paid or honorary, full time or part time while in the service of the this institute.
- 10) Your services are transferable to any other institute run by D.Y.Patil Group.
- 11) You will have to give one month's notice or pay/forgo one month's salary in lieu of the notice period while resigning the job.It is desirable that being a teaching faculty , you do not leave the job when the teaching session is in progress.
- 12) a) If it is observed that your performance is not satisfactory /your behaviour is not in the interest of the institute/trust/ you commit breach of the terms and conditions governing your appointment/you are found medically unfit (physically/mentally) ,your services shall be terminated without giving any notice period.
- b) Your continuous unauthorized absence from duty for more than fifteen days shall lead to automatic termination of your services from the date from which you remain absent.
- c) If you are not selected and recommended for regularization by the Selection Committee constituted as per norms of the University, your services shall terminated with effect from the date on which the candidate selected by the said committee reports for duty.

Yours faithfully,

**For Dr.D.Y.Patil Educational Enterprises Charitable Trust**

*B.G. Bhandarkar*

**Prof.B.G.Bhandarkar  
Director Corporate Relations  
Authorised Signatory**

Copy to

- ✓ 1 Principal/Director Dr.D.Y.Patil School of Engineering  
[ 2 copies ✓Personal File 2.Accounts Section ]
- 2 Chief Administrative Officer
- 3 DYPEECT Master File

*Dr. D. Y. Patil  
Educational Enterprises  
Charitable Trust*

*Dr. D. Y. Patil  
Educational Enterprises  
Charitable Trust*



Dr D Y PATIL GROUP

Dr D Y PATIL EDUCATIONAL ENTERPRISES CHARITABLE TRUST

No.DrDYPEECT/IC/APP/SoE/ 13-055

Date : 17.6.2013

APPOINTMENT ORDER

To:

Shri.Paresh Pravin Khairnar

E Mail : khairnar.paresh@yahoo.com

Mobile : +91 92257 35612

Sub : Appointment to the Post of **Lecturer in Mechanical Engineering**  
at Dr.D.Y.Patil School of Engineering Pune

Sir,

With reference to the subject mentioned above, we have pleasure to inform you that you are appointed as **Lecturer in Mechanical Engineering** at Dr.D.Y.Patil School of Engineering at Dr.D.Y.Patil Knowledge City, Charholi Bk., Via Lohegaon, Pune 412 105. This appointment is subject to the following terms and conditions :

- 1) The appointment will be effective from the date of your joining the duties .
- 2) The appointment is on temporary ad-hoc basis .You will have to apply and appear for interview before a Selection Committee constituted as per norms of Pune University as and when the posts are advertised, for regularization of your appointment. The continuation of your appointment is subject to your performance , recommendations and decision of this committee.
- 3) You will be paid basic salary of Rs.8,000/- (Rs.Eight thousand only ) in the pay scale of Rs.8000-275-13500 and other allowances as prescribed by the Trust from time to time.. The salary payments will be subject to deduction of statutory taxes as applicable
- 4) You will have to perform duties as mentioned below
  - a) To teach the subject/s assigned to you by the Principal/ Director of the School (Theory as well as Practicals ) in accordance with the syllabus of the University.
  - b) To carry out any other duties as may be assigned to you from time to time by the Principal/Director of the School for smooth conduct of academic and allied co-curricular programmes and conduct of various institute and university examinations including assessment of papers.
  - c) To participate in various skill development /reorientation / training programmes aimed at upgrading teaching capabilities of teaching faculty.
- 5) For discharge of your duties you will be responsible to the Principal/ Director of the School of Engineering and subject the rules and regulations as laid down by the University, AICTE , State Government and the Trust.
- 6) While joining the duties, you will have to submit two sets of certified true copies of documents in support of your qualifications , experience, discharge certificate from previous employer and three recent passport size photographs and execute an agreement as prescribed by the Trust..

Received  
17/6/13

Phairnar  
26/6/13

- 7) You will be required to undergo medical examination before Medical Officer attached to the Dr.D.Y.Patil Knowledge City when medical check up of staff of the Institutions under Dr.D.Y.Patil Knowledge City Campus is organized .
- 8) You will have to submit your correct mailing address on joining he duties and also keep the Principal/ Director of the School informed about subsequent changes, if there be any. The communication sent by the institute by RPAD on the address given by you shall be deemed to have been received and acknowledged by you.
- 9) You will not conduct or engage yourself in any private tuitions or private coaching classes., will not engage yourself in any other job, paid or honorary, full time or part time while in the service of the this institute.
- 10) Your services are transferable to any other institute run by D.Y.Patil Group.
- 11) You will have to give one month's notice or pay/forgo one month's salary in lieu of the notice period while resigning the job.It is desirable that being a teaching faculty , you do not leave the job when the teaching session is in progress.
- 12) a) If it is observed that your performance is not satisfactory /your behaviour is not in the interest of the institute/trust/ you commit breach of the terms and conditions governing your appointment/you are found medically unfit (physically/mentally) ,your services shall be terminated without giving any notice period.  
b) Your continuous unauthorized absence from duty for more than fifteen days shall lead to automatic termination of your services from the date from which you remain absent.  
c) If you are not selected and recommended for regularization by the Selection Committee constituted as per norms of the University, your services shall terminated with effect from the date on which the candidate selected by the said committee reports for duty.

Yours faithfully,

For Dr.D.Y.Patil Educational Enterprises Charitable Trust

  
Prof. B. G. Bhandarkar  
Director Corporate Relations  
Authorised Signatory

Copy to

- 1 Director Dr.D.Y.Patil School of Engineering  
[ 2 copies ✓ Personal File 2.Accounts Section ]
- 2 Chief Financial Officer Head office
- 3 DYPEECT Master File

*Handwritten notes and signatures at the bottom left of the page.*

*Handwritten notes and signatures at the bottom right of the page.*





Dr. D. Y. PATIL GROUP

**Dr D Y PATIL EDUCATIONAL ENTERPRISES CHARITABLE TRUST**

No.DrDYPEECT/IC/APP/SoE/ 12-074

Date : . 20. 7. 2012

**APPOINTMENT ORDER**

To:

**Shri. Yogesh S. Gandal**

Mobile : +91 97302 56318

E Mail : ganyog4@gmail.com

**Sub :** Appointment to the Post of **Lecturer in Mechanical Engineering**  
at Dr.D.Y.Patil School of Engineering ,Pune

Sir,

With reference to the subject mentioned above, we have pleasure to inform you that you are appointed as **Lecturer in Mechanical Engineering** at Dr.D.Y.Patil School of Engineering at Dr.D.Y.Patil Knowledge City, Charholi Bk.,Via Lohegaon, Pune 412 105.This appointment is subject to the following terms and conditions :

- 1) The appointment will be effective from the date of your joining the duties .
- 2) The appointment is on temporary ad-hoc basis .You will have to apply and appear for interview before a Selection Committee constituted as per norms of Pune University as and when the posts are advertised, for regularization of your appointment. The continuation of your appointment is subject to your performance , recommendations and decision of this committee.
- 3) You will be paid basic salary of Rs.8,000/-(Rs. Eight thousand only ) in the pay scale of Rs.8,000-275-13,500 and other allowances as prescribed by the Trust from time to timeThe salary payments will be subject to deduction of statutory taxes as applicable.
- 4) You will have to perform duties as mentioned below
  - a) To teach the subject/s assigned to you by the Director of the School (Theory as well as Practicals ) in accordance with the syllabus of the University.
  - b) To carry out any other duties as may be assigned to you from time to time by the Director of the School for smooth conduct of academic and allied co-curricular programmes and conduct of various institute and university examinations including assessment of papers.
  - c) To participate in various skill development /reorientation / training programmes aimed at upgrading teaching capabilities of teaching faculty.
- 5) For discharge of your duties you will be responsible to the Director of the School of Engineering and subject to the rules and regulations as laid down by the University, AICTE and State Government.

Received  
Gandal  
24/7/12

- 6) While joining the duties, you will have to submit two sets of certified true copies of documents in support of your qualifications , experience, discharge certificate from previous employer and three recent passport size photographs and execute an agreement as prescribed by the Trust..
- 7) You will be required to undergo medical examination before Medical Officer attached to the Technical Campus when medical check up of staff of the Institutions under Technical Campus is organized .
- 8) You will have to submit your correct mailing address on joining he duties and also keep the Director of the School informed about subsequent changes, if there be any. The communication sent by the institute by RPAD on the address given by you shall be deemed to have been received and acknowledged by you.
- 9) You will not conduct or engage yourself in any private tuitions or private coaching classes., will not engage yourself in any other job, paid or honorary, full time or part time while in the service of the this institute.
- 10) Your services are transferable to any other institute run by D.Y.Patil Group.
- 11) You will have to give one month's notice or pay/forgo one month's salary in lieu of the notice period while resigning the job.It is desirable that being a teaching faculty , you do not leave the job when the teaching session is in progress.
- 12) a) If it is observed that your performance is not satisfactory /your behaviour is not in the interest of the institute/trust/ you commit breach of the terms and conditions governing your appointment/you are found medically unfit (physically/mentally) ,your services shall be terminated without giving any notice period.  
b) Your continuous unauthorized absence from duty for more than fifteen days shall lead to automatic termination of your services from the date from which you remain absent.  
c) If you are not selected and recommended for regularization by the Selection Committee constituted as per norms of the University, your services shall terminated with effect from the date on which the candidate selected by the said committee reports for duty.

Yours faithfully,

**For Dr.D.Y.Patil Educational Enterprises Charitable Trust**

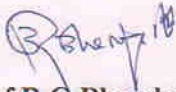

**Prof.B.G.Bhandarkar**  
**Director Corporate Relations**  
**Authorised Signatory**

Copy to

- 1 Director Dr.D.Y.Patil School of Engineering  
[ 2 copies 1 .Personal File 2.Accounts Section ]
- 2 Chief Financial Officer Head office
- 3 DYPEECT Master File

Received  
26/12/12



**D Y PATIL GROUP**  
**Dr D Y PATIL EDUCATIONAL ENTERPRISES CHARITABLE TRUST**

No.DrDYPEECT/IC/APP/SoE/14-078  
Date : 29.05.2014

**APPOINTMENT ORDER**

To:  
**Mr. Amol N.Patil**  
E Mail :  
Mobile : +91 90496 16886

**Sub :** Appointment to the Post of **Asstt Prof of Mechanical Engineering** at Dr.D.Y.Patil School of Engineering Pune

Sir ,

With reference to the subject mentioned above, we have pleasure to inform you that you are appointed as **Asstt. Professor of Mechanical Engineering** at Dr.D.Y.Patil School of Engineering at Dr.D.Y.Patil Knowledge City, Charholi Bk.,Via Lohegaon, Pune 412 105.This appointment is subject to the following terms and conditions :

- 1) The appointment will be effective from the date of your joining the duties .
- 2) The appointment is on temporary ad-hoc basis .You will have to apply and appear for interview before a Selection Committee constituted as per norms of Pune University as and when the posts are advertised, for regularization of your appointment. The continuation of your appointment is subject to your performance , recommendations and decision of this committee.
- 3) You will be paid consolidated salary of Rs.54,000/- (Rs.Fifty four thousand only ) per month. No.other allowances will be admissible..The salary payments will be subject to deduction of statutory taxes as applicable.
- 4) You will have to perform duties as mentioned below
  - a) To teach the subject/s assigned to you by the Principal/Director of the School (Theory as well as Practicals ) in accordance with the syllabus of the University.
  - b) To carry out any other duties as may be assigned to you from time to time by the Principal/Director of the School for smooth conduct of academic and allied co-curricular programmes and conduct of various institute and university examinations including assessment of papers.
  - c) To participate in various skill development /reorientation / training programmes aimed at upgrading teaching capabilities of teaching faculty.
- 5) For discharge of your duties you will be responsible to the Principal/ Director of the School of Engineering and subject the rules and regulations as laid down by the University, AICTE and State Government & Trust .
- 6) While joining the duties, you will have to submit two sets of certified true copies of documents in support of your qualifications , experience, discharge certificate from previous employer and three recent passport size photographs and execute an agreement as prescribed by the Trust..

- 7) You will be required to undergo medical examination before Medical Officer attached to the .Dr.D.Y.Patil Knowledge City Campus when medical check up of staff of the Institutions in the Dr.D.Y.Patil Knowledge City Campus is organized .
- 8) You will have to submit your correct mailing address on joining he duties and also keep the Director of the School informed about subsequent changes, if there be any. The communication sent by the institute by RPAD on the address given by you shall be deemed to have been received and acknowledged by you.
- 9) You will not conduct or engage yourself in any private tuitions or private coaching classes., will not engage yourself in any other job, paid or honorary, full time or part time while in the service of the this institute.
- 10) Your services are transferable to any other institute run by D.Y.Patil Group.
- 11) You will have to give one month's notice or pay/forgo one month's salary in lieu of the notice period while resigning the job.It is desirable that being a teaching faculty , you do not leave the job when the teaching session is in progress.
- 12) a) If it is observed that your performance is not satisfactory /your behaviour is not in the interest of the institute/trust/ you commit breach of the terms and conditions governing your appointment/you are found medically unfit (physically/mentally) ,your services shall be terminated without giving any notice period.  
b) Your continuous unauthorized absence from duty for more than fifteen days shall lead to automatic termination of your services from the date from which you remain absent.  
c) If you are not selected and recommended for regularization by the Selection Committee constituted as per norms of the University, your services shall terminated with effect from the date on which the candidate selected by the said committee reports for duty.

Yours faithfully,

**For Dr.D.Y.Patil Educational Enterprises Charitable Trust**

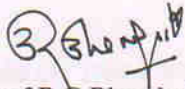

**Prof.B.G.Bhandarkar**  
**Director Corporate Relations**  
**Authorised Signatory**

Copy to

- 1 Principal/Director Dr.D.Y.Patil School of Engineering  
[ 2 copies 1 .Personal File ✓2.Accounts Section ]
- 2 Chief Financial Officer Head office
- 3 DYPEECT Master File



**DR D Y PATIL GROUP**

Dr. D. Y. Patil Educational Enterprises Charitable Trust's

Dr D Y PATIL TECHNICAL CAMPUS

**Dr D Y PATIL SCHOOL OF ENGINEERING**

DrDYPEECT /DYP SOE/US/APP/2017/

Date: 08.05.2017

**APPOINTMENT ORDER**

Tejaswini Suhas Kulkarni,  
Som balaji darshan , behind Ranka jewellers,  
Dapsar, Pune.

**Subject:** Appointment to the Post of **Assistant Professor in Mechanical Engg** at **Dr. D Y Patil School of Engineering.**

In reference to your application for the post of **Assistant Professor in Mechanical Engg**, in response to advertisement on 6<sup>th</sup> February, 2017 in Indian Express and Loksatta and subsequent interview on 26<sup>th</sup> March, 2017 before Selection Committee constituted by Savitribai Phule Pune University. We have pleasure in informing you that you are selected by the committee and appointed as **Assistant Professor in Mechanical Engg** at Dr. D Y Patil School of Engineering, Dr. D. Y. Patil Knowledge City, Charholi Bk, Via Lohegaon, Pune 412 105. The Appointment is subject to the following terms & conditions;

This appointment is effective from the date of your joining the duties. You will have to join the duties within **15 days** from the date of this appointment order i.e. **by 15<sup>th</sup> May, 2017**. In the event you do not join the duties within this time limit it will be assumed that you do not intend to join the duties and the appointment order issued in your favour will stand automatically cancelled.

However in case you need an extension of time limit for joining the duties you will have to apply in writing for grant of extension stating the reasons for the same and indicating the date on which you intend to join the duties. The request for grant of extension of time limit for joining the duties of the post shall be considered and you will be informed in the matter. The decision of the management of Dr. D Y Patil School of Engineering shall be final.

You will be governed by the Maharashtra Universities Act, statutes, ordinances, rules & regulations, code of conduct, laid down by the Savitribai Phule Pune University, Government of Maharashtra and service rules of the Trust and will be responsible to the Director or the Institute for discharge of your duties.

The post is for **Open (W)** category and since you belong to **Open (W)** category you are appointed in clear vacancy on fulltime basis and you will be on probation for a period of two years from the date of joining the duties subject to approval by Savitribai Phule Pune University. The continuation beyond probation period will be subject to your satisfactory completion of probation.

You will be paid basic salary of **Rs. 15600/-** (in words Rs. Fifteen Thousand Six Hundred Only) plus Academic Grade\*Pay of **Rs. 06,000/-** (Rs. Six Thousand Only) per month in the pay scale of **Rs. 15600-39100**.

Salary payment will be subject to deduction of statutory taxes as applicable.

[PTC]

Received *Kullu*



Dr. D. Y. Patil Educational Enterprises Charitable Trust's  
Dr D Y PATIL TECHNICAL CAMPUS

## Dr D Y PATIL SCHOOL OF ENGINEERING

DrDYPEECT /DYP SOE/US/APP/2017/

Date: 08.05.2017

### APPOINTMENT ORDER

Ms. Pooja Rajendra Nawathe,  
O Anjali D Kapse, Dipanjali bld,  
Sinhath Colony Krishna Chowk  
Vandriwale, Pune

Subject: Appointment to the Post of **Assistant Professor in Mechanical Engg** at **Dr. D Y Patil School of Engineering**.

In reference to your application for the post of **Assistant Professor in Mechanical Engg**, in response to advertisement on 6<sup>th</sup> February, 2017 in Indian Express and Loksatta and subsequent interview on 26<sup>th</sup> March, 2017 before Selection Committee constituted by Savitribai Phule Pune University. We have pleasure in informing you that you are selected by the committee and appointed as **Assistant Professor in Mechanical Engg** at Dr. D Y Patil School of Engineering, Dr. D. Y. Patil Knowledge City, Charholi Bk, Via Lohegaon, Pune 412 105. The Appointment is subject to the following terms & conditions;

This appointment is effective from the date of your joining the duties. You will have to join the duties within **15 days** from the date of this appointment order i.e. **by 15<sup>th</sup> May, 2017**. In the event you do not join the duties within this time limit it will be assumed that you do not intend to join the duties and the appointment order issued in your favour will stand automatically cancelled.

However in case you need an extension of time limit for joining the duties you will have to apply in writing for grant of extension stating the reasons for the same and indicating the date on which you wish to join the duties. The request for grant of extension of time limit for joining the duties of the post shall be considered and you will be informed in the matter. The decision of the management of the Dr. D Y Patil School of Engineering shall be final.

You will be governed by the Maharashtra Universities Act, statutes, ordinances, rules & regulations, code of conduct, laid down by the Savitribai Phule Pune University, Government of Maharashtra and the service rules of the Trust and will be responsible to the Director of the Institute for discharge of your duties.

The post is for **NTD** category and since you belong to **NTD** category you are appointed in clear vacancy on fulltime basis and you will be on probation for a period of two years from the date of joining the duties subject to approval by Savitribai Phule Pune University. The continuation beyond probation period will be subject to your satisfactory completion of probation.

You will be paid basic salary of **Rs. 15600/-** (In words Rs. Fifteen Thousand Six Hundred Only) plus Academic Grade Pay of **Rs. 06,000/-** (Rs. Six Thousand Only) per month in the pay scale of **Rs. 15600-39100**.

The Salary payment will be subject to deduction of statutory taxes as applicable.

Received  
Pooja

[PTO]

You will have to perform duties as mentioned below:

To teach the subject/s assigned to you by the Head of Department/ Institute (theory as well as practicals) in accordance with syllabus of the Savitribai Phule Pune University.

To carry out any other duties as may be assigned to you from time to time by the Head of Department / Institute for smooth conduct of academic and allied co-curricular activities as well as conduct of various institute level and university examinations.

To participate in various skill development / reorientation / training programmes.

You shall undergo medical examination before Medical Officer attached with Dr. D Y Patil Knowledge Institute within three months from the date of joining the duties. The appointment shall be provisional and conditional, pending submission of Medical Certificate stating that you are free from any contagious disease and you are physically fit for employment as the staff of the Institute.

You will not engage yourself in any private tuitions or private coaching classes, will not engage yourself in any other job, paid or honorary, full time or part time, while in the service of the institute. You will not undertake any R & D or consultancy work and not register for any degree / diploma / certificate course without approval of the competent authority of the Trust.

3. While joining the duties you will have to submit a) Last Pay Slip from the previous Employer b) Two recent pass-post size photographs c) Two copies of the certificates in support of your qualifications & experience.

9. You will have to submit your correct mailing address while joining the duties and also inform in writing to the Head of the Institute about subsequent changes, if there be any. The communication sent by RPAD on the address given by you shall be deemed to have been received by you.

10. You will have to give one months notice or pay / forgo one month's salary in lieu of notice period while resigning the job. It is desirable that being a teaching faculty, you do not leave the job when the academic session is in progress.

11. a) If it is observed that your performance is not satisfactory / your behavior is not in the interest of the institute / trust / you commit breach of terms and conditions governing your appointment / you are found medically unfit (physically/mentally), your services shall be terminated without giving any notice period.

b) Your continuous unauthorized absence from duty for more than **fifteen days** shall lead to automatic termination of your services from the date you remain absent from duties.

c) **In view of this appointment order, the previous order stands cancelled.**

d) While joining the duties you will have to give an undertaking that you have read and understood the terms & conditions governing your appointment and that you will abide by them.

Yours faithfully,

For Dr. D. Y. Patil Educational Enterprises Charitable Trust

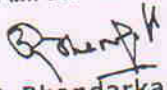
  
(Prof. B. G. Bhandarkar)  
Secretary, DYPEECT.  
Authorized Signatory

Copy to:

1. Director, Dr. D Y Patil School of Engineering  
(2 copies - 1. Personal File 2. Accounts Section)
2. Chief Administrative Officer
3. Chief Financial Officer.



## Dr D Y PATIL EDUCATIONAL ENTERPRISES CHARITABLE TRUST

Ref. ADYPKC/SOE/AO/T/MA/2020-21/ 2.2

Date: 21.08.2020

To,  
Dr. Mohd Imran Ansari  
Room No-15, PhD Scholar Hostel,  
DIAT (DU),  
Girinagar,  
Pune-411025  
Email- [imransarimech@gmail.com](mailto:imransarimech@gmail.com)  
Contact- 7972076138

### Appointment Order

Dr. Mohd Imran Ansari,

Following your application and subsequent interview for the post of **Assistant Professor**, I am pleased to inform you that the Management has appointed you as **Assistant Professor in Mechanical Engineering Department at Dr. D Y Patil School of Engineering**. The terms & conditions of the appointment are as follows.

- 1) Your services are governed by the Maharashtra Universities Act, statues, ordinances, rules & regulations, code of conduct, laid down by the Savitribai Phule Pune University, Government of Maharashtra and service rules of the Trust and will be responsible to the Principal/Director of the Institute for discharge of your duties.
- 2) Your appointment is on **purely temporary basis** for a period of **Academic Year 2020-21 (i.e. upto 31<sup>st</sup> May 2021 only)** from the date of joining i.e. 21<sup>st</sup> August 2020.
- 3) You will be paid consolidated monthly salary of **Rs. 36,950 Only (Rs Thirty Six Thousand Nine Hundred Fifty Only)**. No other allowances will be admissible. The salary payment will be subject to statutory deduction of taxes as applicable.
- 4) Your appointment is subject to the minimum numbers of the students and the sufficient workload prescribed for the post.
- 5) Your appointment is on purely temporary basis and will automatically come to an end on the expiry of tenure and in any such event; you shall not claim any right to be continued in the services. You shall not claim to be a regular/permanent employee of the Institute/College. At any time during the tenure of your services or after termination thereof, in any manner whatsoever, and shall not claim automatic re-appointment to the said post after expiry of the tenure of your services and you will not be eligible for any retiral benefits.
- 6) You shall submit the certified true copies of relevant documents such as birth certificate, mark sheets, experience certificates, Approval Letters, reliving certificate, Aadhar Card, PAN card, Last Pay Slip from the previous Employer before joining the duties.
- 7) You will produce 2 passport size recent photographs.
- 8) You are required to give the correct mailing address as soon as you join your duties. It will be presumed that any letter sent by Registered Post Acknowledgement Due (RPAD) or Speed Post or E-Mail on the address given, shall be deemed to have been acknowledged duly signed by you.
- 9) You are entitled Casual Leave as per Rules & Regulation of DYPEECT, subject to changes from time to time.
- 10) You are entitled for Medical Leave only after completion of one-year regular services and as per Rules & Regulation of DYPEECT, subject to changes from time to time.
- 11) If you want to leave the service during the tenure of your appointment, you will have to give one month's notice in writing to the Management. A sum equal to your one months' salary will be deducted or you will need to deposit the same amount to employer in case you resign without serving a one months' notice period. It is desirable that being a teaching faculty, you do not leave the job when the academic session is in progress.
- 12) You will submit to the office the medical fitness certificate from the Registered Medical panel appointed by the DYPEECT before joining your duties.

Page 1 of 2

Received  
21/08/20



- 13) You will not conduct or engage yourself in private tuitions or private coaching classes.
- 14) You will not engage yourself in any other paid job, full time, part time, honorary or otherwise during the continuance of your service in this Institute/College. You will not undertake any R & D or consultancy work and not register for any degree / diploma / certificate course without approval of the competent authority of the Trust.
- 15) You will not appear for any examinations/Admission without prior permission of the management in service.
- 16) You will not take any active part in the politics, neither involved directly or indirectly in illegal financial matters.
- 17) Your services are transferable within the trust organization only.
- 18) You will not directly or indirectly get yourself involved in any of the anti-activities against the management which may cause any harm to the institute/college or the management.
- 19) Your behavior with colleagues and entire institute/college staff should be polite, co-operative and gentle.
- 20) You will not form any union or organization amongst yourself and colleagues.
- 21) You will not process any letters either signed by you or signed jointly on any issues against the Management/Authorities without prior permission of the Principal/Director. Also, you will not approach to any authorities connected to the Institute/ College / Trust without prior permission of the Principal / Director.
- 22) You will put your grievances to the Management through Principal / Director only.
- 23) You will have to carry out the duties / work assigned to you by the Principal / Director and the Management besides your teaching work / routine work.
- 24) If you found absent continuously for more than 15 days without prior written permission from the Principal/Director, your services will stand terminated automatically and no further correspondence will be entertained thereafter.
- 25) Any information given in the application form if found incorrect contradictory at any time after the appointment, your services will be terminated forthwith, and no further correspondence will be entertained thereafter.
- 26) Progress Report: You will submit your academic progress report and other activities, seminars, presentation of papers, workshop, Self Appraisal etc. twice every year in the months of April and November.
- 27) If it is observed that your performance is not satisfactory / your behavior is not in the interest of the institute or College or trust / you commit breach of terms and conditions as mentioned in your appointment / you are found medically unfit (physically/mentally), your services shall be terminated without giving any notice period.
- 28) You will have to communicate your acceptance in writing to the Management/Director/Principal **within two weeks** from the date of receipt of Order of Appointment, failing which your appointment is liable to be withdrawal / cancelled. However, in case you need an extension of time limit for joining the duties you will have to apply in writing for grant of extension stating the reasons for the same and indicating the date on which you intend to join the duties. The request for grant of extension of time limit for joining the duties for the post shall be considered and you will be informed in the matter. The decision of the management of the **Dr. D Y Patil School of Engineering** shall be final.
- 29) If you are found guilty of violation of any terms & conditions mentioned above you will be liable for disciplinary action and punishment decided by the Management/Director/ Principal as provided in the Rules & Regulations.
- 30) In view of this appointment order, the previous appointment order/s stands cancelled.
- 31) Any dispute arises in the service will be dealt legally in jurisdiction of Pune City only.

*For Dr. D Y Patil Educational Enterprises Charitable Trust*

*Hridaysh*  
**Hridaysh Deshpande**  
 Authorized Signatory



**Copy to:**

- 1 Master File DYPEECT.
- 2 Principal, Dr. D Y Patil School of Engineering  
(Two Copies: [1] Personal File [2] Accounts Section).
- 3 Chief Financial Officer, DYPEECT.



**Dr D Y PATIL EDUCATIONAL ENTERPRISES CHARITABLE TRUST**

Ref.ADYPKC/ITC/T/LSSC/2020-21/016 | 01

Date: 15/06/2020

To,  
**Dr.Sayyad Farook Bashir**  
203, Mayfair elegant,  
Tadiwala Road,  
Pune-41001  
Email- fbsayyad@gmail.com  
Contact- 9422646654

**Appointment order**

**Dr.Sayyad Farook Bashir,**

Following your application and subsequent interview for the post of **Professor**, I am pleased to inform you that the Management has appointed you as **Professor** in **Mechanical Engineering Department at Dr. D Y Patil School of Engineering**. The terms & conditions of the appointment are as follows.

- 1) Your services are governed by the Maharashtra Universities Act, statues, ordinances, rules & regulations, code of conduct, laid down by the Savitribai Phule Pune University, Government of Maharashtra and service rules of the Trust and will be responsible to the Principal/Director of the Institute for discharge of your duties.
- 2) Your appointment is on **purely temporary basis** for a period of **Academic Year 2020-21 (i.e. upto 31<sup>st</sup> May 2021 only)** from the date of joining i.e.15<sup>th</sup> June 2020.
- 3) You will be paid consolidated monthly salary of **Rs. 1, 25,355 (Rs One lakh Twenty five Thousand Three Hundered & Fifty Five Only)**. No other allowances will be admissible. The salary payment will be subject to statutory deduction of taxes as applicable.
- 4) Your appointment is subject to the minimum numbers of the students and the sufficient workload prescribed for the post.
- 5) Your appointment is on purely temporary basis and will automatically come to an end on the expiry of tenure and in any such event; you shall not claim any right to be continued in the services. You shall not claim to be a regular/permanent employee of the Institute/College. At any time during the tenure of your services or after termination thereof, in any manner whatsoever, and shall not claim automatic re-appointment to the said post after expiry of the tenure of your services and you will not be eligible for any retiral benefits.
- 6) You shall submit the certified true copies of relevant documents such as birth certificate, mark sheets, experience certificates, Approval Letters, reliving certificate, Aadhar Card, PAN card, Last Pay Slip from the previous Employer before joining the duties.
- 7) You will produce 2 passport size recent photographs.
- 8) You are required to give the correct mailing address as soon as you join your duties. It will be presumed that any letter sent by Registered Post Acknowledgement Due (RPAD) or Speed Post or E-Mail on the address given, shall be deemed to have been acknowledged duly signed by you.
- 9) You are entitled Casual Leave as per Rules & Regulation of DYPEECT, subject to changes from time to time.
- 10) You are entitled for Medical Leave only after completion of one-year regular services and as per Rules & Regulation of DYPEECT, subject to changes from time to time.
- 11) If you want to leave the service during the tenure of your appointment, you will have to give one month's notice in writing to the Management. A sum equal to your one months' salary will be deducted or you will need to deposit the same amount to employer in case you resign without serving a one months' notice period. It is desirable that being a teaching faculty, you do not leave the job when the academic session is in progress.
- 12) You will submit to the office the medical fitness certificate from the Registered Medical panel appointed by the DYPEECT before joining your duties.



*Received*  
*[Signature]*  
*11/7/20*

- 13) You will not conduct or engage yourself in private tuitions or private coaching classes.
- 14) You will not engage yourself in any other paid job, full time, part time, honorary or otherwise during the continuance of your service in this Institute/College. You will not undertake any R & D or consultancy work and not register for any degree / diploma / certificate course without approval of the competent authority of the Trust.
- 15) You will not appear for any examinations/Admission without prior permission of the management in service.
- 16) You will not take any active part in the politics, neither involved directly or indirectly in illegal financial matters.
- 17) Your services are transferable within the trust organization only.
- 18) You will not directly or indirectly get yourself involved in any of the anti-activities against the management which may cause any harm to the institute/college or the management.
- 19) Your behavior with colleagues and entire institute/college staff should be polite, co-operative and gentle.
- 20) You will not form any union or organization amongst yourself and colleagues.
- 21) You will not process any letters either signed by you or signed jointly on any issues against the Management/Authorities without prior permission of the Principal/Director. Also, you will not approach to any authorities connected to the Institute/ College / Trust without prior permission of the Principal / Director.
- 22) You will put your grievances to the Management through Principal / Director only.
- 23) You will have to carry out the duties / work assigned to you by the Principal / Director and the Management besides your teaching work / routine work.
- 24) If you found absent continuously for more than 15 days without prior written permission from the Principal/Director, your services will stand terminated automatically and no further correspondence will be entertained thereafter.
- 25) Any information given in the application form if found incorrect contradictory at any time after the appointment, your services will be terminated forthwith, and no further correspondence will be entertained thereafter.
- 26) Progress Report: You will submit your academic progress report and other activities, seminars, presentation of papers, workshop, Self Appraisal etc. twice every year in the months of April and November.
- 27) If it is observed that your performance is not satisfactory / your behavior is not in the interest of the institute or College or trust / you commit breach of terms and conditions as mentioned in your appointment / you are found medically unfit (physically/mentally), your services shall be terminated without giving any notice period.
- 28) You will have to communicate your acceptance in writing to the Management/Director/Principal **within two weeks** from the date of receipt of Order of Appointment, failing which your appointment is liable to be withdrawal / cancelled. However, in case you need an extension of time limit for joining the duties you will have to apply in writing for grant of extension stating the reasons for the same and indicating the date on which you intend to join the duties. The request for grant of extension of time limit for joining the duties for the post shall be considered and you will be informed in the matter. The decision of the management of the **Dr. D Y Patil School of Engineering** shall be final.
- 29) If you are found guilty of violation of any terms & conditions mentioned above you will be liable for disciplinary action and punishment decided by the Management/Director/ Principal as provided in the Rules & Regulations.
- 30) In view of this appointment order, the previous appointment order/s stands cancelled.
- 31) Any dispute arises in the service will be dealt legally in jurisdiction of Pune City only.

For Dr. D Y Patil Educational Enterprises Charitable Trust

*Hrridaysh*  
**Hrridaysh Deshpande**  
**Authorized Signatory**



*Received*  
*[Signature]*  
 01/07/20

**Copy to:**

- 1 Master File DYPEECT.
- 2 Principal, Dr. D Y Patil School of Engineering  
(Two Copies: [1] Personal File [2] Accounts Section).
- 3 Chief Financial Officer, DYPEECT.



D Y PATIL GROUP

Dr D Y PATIL EDUCATIONAL ENTERPRISES CHARITABLE TRUST

Ref.ADYPKC/ITC/T/LSSC/2020-21/018 /02

Date: 15/06/2020

To,  
Mr.Rohit Nagesh Garad  
S.No 23/2, Royal Court,  
Flat No. A/203,  
Near Anand Park,  
Pune-411033  
Email- rohitgarad@rediffmail.com  
Contact- 9822450792

Appointment order

Mr.Rohit Nagesh Garad,

Following your application and subsequent interview for the post of **Assistant Professor**, I am pleased to inform you that the Management has appointed you as **Assistant Professor** in **Mechanical Engineering Department at Dr. D Y Patil School of Engineering**. The terms & conditions of the appointment are as follows.

- 1) Your services are governed by the Maharashtra Universities Act, statutes, ordinances, rules & regulations, code of conduct, laid down by the Savitribai Phule Pune University, Government of Maharashtra and service rules of the Trust and will be responsible to the Principal/Director of the Institute for discharge of your duties.
- 2) Your appointment is on **purely temporary basis** for a period of **Academic Year 2020-21 (i.e. upto 31<sup>st</sup> May 2021 only)** from the date of joining i.e. **15<sup>th</sup> June 2020**.
- 3) You will be paid consolidated monthly salary of **Rs. 60,000 (Rs Sixty Thousand Only)**. No other allowances will be admissible. The salary payment will be subject to statutory deduction of taxes as applicable
- 4) Your appointment is subject to the minimum numbers of the students and the sufficient workload prescribed for the post.
- 5) Your appointment is on purely temporary basis and will automatically come to an end on the expiry of tenure and in any such event; you shall not claim any right to be continued in the services. You shall not claim to be a regular/permanent employee of the Institute/College. At any time during the tenure of your services or after termination thereof, in any manner whatsoever, and shall not claim automatic re-appointment to the said post after expiry of the tenure of your services and you will not be eligible for any retiral benefits.
- 6) You shall submit the certified true copies of relevant documents such as birth certificate, mark sheets, experience certificates, Approval Letters, reliving certificate, Aadhar Card, PAN card, Last Pay Slip from the previous Employer before joining the duties.
- 7) You will produce 2 passport size recent photographs.
- 8) You are required to give the correct mailing address as soon as you join your duties. It will be presumed that any letter sent by Registered Post Acknowledgement Due (RPAD) or Speed Post or E-Mail on the address given, shall be deemed to have been acknowledged duly signed by you.
- 9) You are entitled Casual Leave as per Rules & Regulation of DYPEECT, subject to changes from time to time.
- 10) You are entitled for Medical Leave only after completion of one-year regular services and as per Rules & Regulation of DYPEECT, subject to changes from time to time.
- 11) If you want to leave the service during the tenure of your appointment, you will have to give one month's notice in writing to the Management. A sum equal to your one months' salary will be deducted or you will need to deposit the same amount to employer in case you resign without serving a one months' notice period. It is desirable that being a teaching faculty, you do not leave the job when the academic session is in progress.
- 12) You will submit to the office the medical fitness certificate from the Registered Medical panel appointed by the DYPEECT before joining your duties.

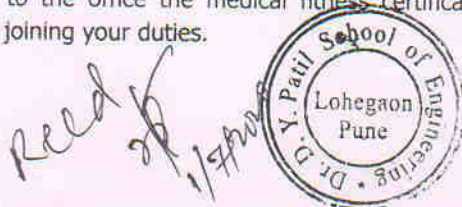

Page 1 of 2

- 13) You will not conduct or engage yourself in private tuitions or private coaching classes.
- 14) You will not engage yourself in any other paid job, full time, part time, honorary or otherwise during the continuance of your service in this Institute/College. You will not undertake any R & D or consultancy work and not register for any degree / diploma / certificate course without approval of the competent authority of the Trust.
- 15) You will not appear for any examinations/Admission without prior permission of the management in service.
- 16) You will not take any active part in the politics, neither involved directly or indirectly in illegal financial matters.
- 17) Your services are transferable within the trust organization only.
- 18) You will not directly or indirectly get yourself involved in any of the anti-activities against the management which may cause any harm to the institute/college or the management.
- 19) Your behavior with colleagues and entire institute/college staff should be polite, co-operative and gentle.
- 20) You will not form any union or organization amongst yourself and colleagues.
- 21) You will not process any letters either signed by you or signed jointly on any issues against the Management/Authorities without prior permission of the Principal/Director. Also, you will not approach to any authorities connected to the Institute/ College / Trust without prior permission of the Principal / Director.
- 22) You will put your grievances to the Management through Principal / Director only.
- 23) You will have to carry out the duties / work assigned to you by the Principal / Director and the Management besides your teaching work / routine work.
- 24) If you found absent continuously for more than 15 days without prior written permission from the Principal/Director, your services will stand terminated automatically and no further correspondence will be entertained thereafter.
- 25) Any information given in the application form if found incorrect contradictory at any time after the appointment, your services will be terminated forthwith, and no further correspondence will be entertained thereafter.
- 26) Progress Report: You will submit your academic progress report and other activities, seminars, presentation of papers workshop, Self Appraisal etc. twice every year in the months of April and November.
- 27) If it is observed that your performance is not satisfactory / your behavior is not in the interest of the institute or College or trust / you commit breach of terms and conditions as mentioned in your appointment / you are found medically unfit (physically/mentally), your services shall be terminated without giving any notice period.
- 28) You will have to communicate your acceptance in writing to the Management/Director/Principal **within two weeks** from the date of receipt of Order of Appointment, failing which your appointment is liable to be withdrawal / cancelled. However, in case you need an extension of time limit for joining the duties you will have to apply in writing for grant of extension stating the reasons for the same and indicating the date on which you intend to join the duties. The request for grant of extension of time limit for joining the duties for the post shall be considered and you will be informed in the matter. The decision of the management of the **Dr. D Y Patil School of Engineering** shall be final.
- 29) If you are found guilty of violation of any terms & conditions mentioned above you will be liable for disciplinary action and punishment decided by the Management/Director/ Principal as provided in the Rules & Regulations.
- 30) In view of this appointment order, the previous appointment order/s stands cancelled.
- 31) Any dispute arises in the service will be dealt legally in jurisdiction of Pune City only.

*For Dr. D Y Patil Educational Enterprises Charitable Trust*

*Hrridaysh*  
**Hrridaysh Deshpande**  
**Authorized Signatory**



**Copy to:**

- 1 Master File DYPEECT.
- 2 Principal, Dr. D Y Patil School of Engineering  
(Two Copies: [1] Personal File [2] Accounts Section).
- 3 Chief Financial Officer, DYPEECT.



## Dr D Y PATIL EDUCATIONAL ENTERPRISES CHARITABLE TRUST

Ref.ADYPKC/SOE/AO/T/VP/2020-21/ 2-3

Date: 10.08.2020

To,  
Mr.Vinod Gopal Patil.  
Olive, D-503,  
Baif Road,  
Wagholi,  
Pune 412 207  
Email- vgpatil@gmail.com  
Contact-9970191393

### Appointment Order

Mr. Vinod Gopal Patil,

Following your application and subsequent interview for the post of **Assistant Professor**, I am pleased to inform you that the Management has appointed you as **Assistant Professor in Mechanical Engineering Department at Dr. D Y Patil School of Engineering**. The terms & conditions of the appointment are as follows.

- 1) Your services are governed by the Maharashtra Universities Act, statues, ordinances, rules & regulations, code of conduct, laid down by the Savitribai Phule Pune University, Government of Maharashtra and service rules of the Trust and will be responsible to the Principal/Director of the Institute for discharge of your duties.
- 2) Your appointment is on **purely temporary basis** for a period of **Academic Year 2020-21 (i.e. upto 31<sup>st</sup> May 2021 only)** from the date of joining i.e.10<sup>th</sup> August 2020.
- 3) You will be paid consolidated monthly salary of **Rs. 35,000 (Rs Thirty Five Thousand Only)**. No other allowances will be admissible. The salary payment will be subject to statutory deduction of taxes as applicable.
- 4) Your appointment is subject to the minimum numbers of the students and the sufficient workload prescribed for the post.
- 5) Your appointment is on purely temporary basis and will automatically come to an end on the expiry of tenure and in any such event; you shall not claim any right to be continued in the services. You shall not claim to be a regular/permanent employee of the Institute/College. At any time during the tenure of your services or after termination thereof, in any manner whatsoever, and shall not claim automatic re-appointment to the said post after expiry of the tenure of your services and you will not be eligible for any retiral benefits.
- 6) You shall submit the certified true copies of relevant documents such as birth certificate, mark sheets, experience certificates, Approval Letters, reliving certificate, Aadhar Card, PAN card, Last Pay Slip from the previous Employer before joining the duties.
- 7) You will produce 2 passport size recent photographs.
- 8) You are required to give the correct mailing address as soon as you join your duties. It will be presumed that any letter sent by Registered Post Acknowledgement Due (RPAD) or Speed Post or E-Mail on the address given, shall be deemed to have been acknowledged duly signed by you.
- 9) You are entitled Casual Leave as per Rules & Regulation of DYPEECT, subject to changes from time to time.
- 10) You are entitled for Medical Leave only after completion of one-year regular services and as per Rules & Regulation of DYPEECT, subject to changes from time to time.
- 11) If you want to leave the service during the tenure of your appointment, you will have to give one month's notice in writing to the Management. A sum equal to your one months' salary will be deducted or you will need to deposit the same amount to employer in case you resign without serving a one months' notice period. It is desirable that being a teaching faculty, you do not leave the job when the academic session is in progress.
- 12) You will submit to the office the medical fitness certificate from the Registered Medical panel appointed by the DYPEECT before joining your duties.

Page 1 of 2

*Qpatil*  
25/08/2020  
Received

- 13) You will not conduct or engage yourself in private tuitions or private coaching classes.
- 14) You will not engage yourself in any other paid job, full time, part time, honorary or otherwise during the continuance of your service in this Institute/College. You will not undertake any R & D or consultancy work and not register for any degree / diploma / certificate course without approval of the competent authority of the Trust.
- 15) You will not appear for any examinations/Admission without prior permission of the management in service.
- 16) You will not take any active part in the politics, neither involved directly or indirectly in illegal financial matters.
- 17) Your services are transferable within the trust organization only.
- 18) You will not directly or indirectly get yourself involved in any of the anti-activities against the management which may cause any harm to the institute/college or the management.
- 19) Your behavior with colleagues and entire institute/college staff should be polite, co-operative and gentle.
- 20) You will not form any union or organization amongst yourself and colleagues.
- 21) You will not process any letters either signed by you or signed jointly on any issues against the Management/Authorities without prior permission of the Principal/Director. Also, you will not approach to any authorities connected to the Institute/ College / Trust without prior permission of the Principal / Director.
- 22) You will put your grievances to the Management through Principal / Director only.
- 23) You will have to carry out the duties / work assigned to you by the Principal / Director and the Management besides your teaching work / routine work.
- 24) If you found absent continuously for more than 15 days without prior written permission from the Principal/Director, your services will stand terminated automatically and no further correspondence will be entertained thereafter.
- 25) Any information given in the application form if found incorrect contradictory at any time after the appointment, your services will be terminated forthwith, and no further correspondence will be entertained thereafter.
- 26) Progress Report: You will submit your academic progress report and other activities, seminars, presentation of papers, workshop, Self Appraisal etc. twice every year in the months of April and November.
- 27) If it is observed that your performance is not satisfactory / your behavior is not in the interest of the institute or College or trust / you commit breach of terms and conditions as mentioned in your appointment / you are found medically unfit (physically/mentally), your services shall be terminated without giving any notice period.
- 28) You will have to communicate your acceptance in writing to the Management/Director/Principal **within two weeks** from the date of receipt of Order of Appointment, failing which your appointment is liable to be withdrawal / cancelled. However, in case you need an extension of time limit for joining the duties you will have to apply in writing for grant of extension stating the reasons for the same and indicating the date on which you intend to join the duties. The request for grant of extension of time limit for joining the duties for the post shall be considered and you will be informed in the matter. The decision of the management of the **Dr. D Y Patil School of Engineering** shall be final.
- 29) If you are found guilty of violation of any terms & conditions mentioned above you will be liable for disciplinary action and punishment decided by the Management/Director/ Principal as provided in the Rules & Regulations.
- 30) In view of this appointment order, the previous appointment order/s stands cancelled.
- 31) Any dispute arises in the service will be dealt legally in jurisdiction of Pune City only.

*For Dr. D Y Patil Educational Enterprises Charitable Trust*

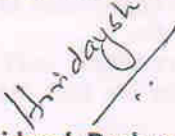
  
**Hrridaysh Deshpande**  
**Authorized Signatory**



**Copy to:**

- 1 Master File DYPEECT.
- 2 Principal, Dr. D Y Patil School of Engineering  
(Two Copies: [1] Personal File [2] Accounts Section).
- 3 Chief Financial Officer, DYPEECT.



D Y PATIL GROUP

Ref. ADYPKC/SOE/AO/T/AS/2020-21/24 Date: 10-08-2020  
D Y PATIL EDUCATIONAL ENTERPRISES CHARITABLE TRUST

Ref. ADYPKC/SOE/AO/T/AS/2020-21/24

Date- 10/08/20

To,  
Mr. Amit Shinde,  
Sr. No. 55/2, Lane No. 6,  
Tulaja Bhawani Nagar,  
Nagar Road, Darga,  
Kharadi,  
Pune  
Email- [shindeamit.shinde1@gmail.com](mailto:shindeamit.shinde1@gmail.com)  
Contact-9172557848

### Appointment Order

Mr. Amit Shinde,

Following your application and subsequent interview for the post of **Assistant Professor**, I am pleased to inform you that the Management has appointed you as **Assistant Professor in Mechanical Engineering Department at Dr. D Y Patil School of Engineering**. The terms & conditions of the appointment are as follows.

- 1) Your services are governed by the Maharashtra Universities Act, statues, ordinances, rules & regulations, code of conduct, laid down by the Savitribai Phule Pune University, Government of Maharashtra and service rules of the Trust and will be responsible to the Principal/Director of the Institute for discharge of your duties.
- 2) Your appointment is on **purely temporary basis** for a period of **Academic Year 2020-21 (i.e. upto 31<sup>st</sup> May 2021 only)** from the date of joining i.e. 10<sup>th</sup> August 2020.
- 3) You will be paid consolidated monthly salary of **Rs. 35,000 Only (Rs Thirty Five Thousand Only)**. No other allowances will be admissible. The salary payment will be subject to statutory deduction of taxes as applicable.
- 4) Your appointment is subject to the minimum numbers of the students and the sufficient workload prescribed for the post.
- 5) Your appointment is on purely temporary basis and will automatically come to an end on the expiry of tenure and in any such event; you shall not claim any right to be continued in the services. You shall not claim to be a regular/permanent employee of the Institute/College. At any time during the tenure of your services or after termination thereof, in any manner whatsoever, and shall not claim automatic re-appointment to the said post after expiry of the tenure of your services and you will not be eligible for any retiral benefits.
- 6) You shall submit the certified true copies of relevant documents such as birth certificate, mark sheets, experience certificates, Approval Letters, relieving certificate, Aadhar Card, PAN card, Last Pay Slip from the previous Employer before joining the duties.
- 7) You will produce 2 passport size recent photographs.
- 8) You are required to give the correct mailing address as soon as you join your duties. It will be presumed that any letter sent by Registered Post Acknowledgement Due (RPAD) or Speed Post or E-Mail on the address given, shall be deemed to have been acknowledged duly signed by you.
- 9) You are entitled Casual Leave as per Rules & Regulation of DYPEECT, subject to changes from time to time.
- 10) You are entitled for Medical Leave only after completion of one-year regular services and as per Rules & Regulation of DYPEECT, subject to changes from time to time.
- 11) If you want to leave the service during the tenure of your appointment, you will have to give one month's notice in writing to the Management. A sum equal to your one months' salary will be deducted or you will need to deposit the same amount to employer in case you resign without serving a one months' notice period. It is desirable that being a teaching faculty, you do not leave the job when the academic session is in progress.
- 12) You will submit to the office the medical fitness certificate from the Registered Medical panel appointed by the DYPEECT before joining your duties.

Received  
Amit  
25.8.2020

Page 1 of 2



- 13) You will not conduct or engage yourself in private tuitions or private coaching classes.
- 14) You will not engage yourself in any other paid job, full time, part time, honorary or otherwise during the continuance of your service in this Institute/College. You will not undertake any R & D or consultancy work and not register for any degree / diploma / certificate course without approval of the competent authority of the Trust.
- 15) You will not appear for any examinations/Admission without prior permission of the management in service.
- 16) You will not take any active part in the politics, neither involved directly or indirectly in illegal financial matters.
- 17) Your services are transferable within the trust organization only.
- 18) You will not directly or indirectly get yourself involved in any of the anti-activities against the management which may cause any harm to the institute/college or the management.
- 19) Your behavior with colleagues and entire institute/college staff should be polite, co-operative and gentle.
- 20) You will not form any union or organization amongst yourself and colleagues.
- 21) You will not process any letters either signed by you or signed jointly on any issues against the Management/Authorities without prior permission of the Principal/Director. Also, you will not approach to any authorities connected to the Institute/ College / Trust without prior permission of the Principal / Director.
- 22) You will put your grievances to the Management through Principal / Director only.
- 23) You will have to carry out the duties / work assigned to you by the Principal / Director and the Management besides your teaching work / routine work.
- 24) If you found absent continuously for more than 15 days without prior written permission from the Principal/Director, your services will stand terminated automatically and no further correspondence will be entertained thereafter.
- 25) Any information given in the application form if found incorrect contradictory at any time after the appointment, your services will be terminated forthwith, and no further correspondence will be entertained thereafter.
- 26) Progress Report: You will submit your academic progress report and other activities, seminars, presentation of papers, workshop, Self Appraisal etc. twice every year in the months of April and November.
- 27) If it is observed that your performance is not satisfactory / your behavior is not in the interest of the institute or College or trust / you commit breach of terms and conditions as mentioned in your appointment / you are found medically unfit (physically/mentally), your services shall be terminated without giving any notice period.
- 28) You will have to communicate your acceptance in writing to the Management/Director/Principal **within two weeks** from the date of receipt of Order of Appointment, failing which your appointment is liable to be withdrawal / cancelled. However, in case you need an extension of time limit for joining the duties you will have to apply in writing for grant of extension stating the reasons for the same and indicating the date on which you intend to join the duties. The request for grant of extension of time limit for joining the duties for the post shall be considered and you will be informed in the matter. The decision of the management of the **Dr. D Y Patil School of Engineering** shall be final.
- 29) If you are found guilty of violation of any terms & conditions mentioned above you will be liable for disciplinary action and punishment decided by the Management/Director/ Principal as provided in the Rules & Regulations.
- 30) In view of this appointment order, the previous appointment order/s stands cancelled.
- 31) Any dispute arises in the service will be dealt legally in jurisdiction of Pune City only.

*For Dr. D Y Patil Educational Enterprises Charitable Trust*

*Hridaysh*  
**Hridaysh Deshpande**  
**Authorized Signatory**



**Copy to:**

- 1 Master File DYPEECT.
- 2 Principal, Dr. D Y Patil School of Engineering  
(Two Copies: [1] Personal File [2] Accounts Section).
- 3 Chief Financial Officer, DYPEECT.



## Dr D Y PATIL EDUCATIONAL ENTERPRISES CHARITABLE TRUST

Ref.ADYPKC/SOE/AO/T/SB/2020-21/ 25

Date: 11.08.2020

To,  
Mr. Sandeep Bhaskar,  
Vastushree Adrina,  
Keshavnagar,  
Mundhwa,  
Pune  
Email- [sandeepbhaskarwin@gmail.com](mailto:sandeepbhaskarwin@gmail.com)  
Contact-9910215645

### Appointment Order

Mr. Sandeep Bhaskar,

Following your application and subsequent interview for the post of **Assistant Professor**, I am pleased to inform you that the Management has appointed you as **Assistant Professor in Mechanical Engineering Department at Dr. D Y Patil School of Engineering**. The terms & conditions of the appointment are as follows.

- 1) Your services are governed by the Maharashtra Universities Act, statues, ordinances, rules & regulations, code of conduct, laid down by the Savitribai Phule Pune University, Government of Maharashtra and service rules of the Trust and will be responsible to the Principal/Director of the Institute for discharge of your duties.
- 2) Your appointment is on **purely temporary basis** for a period of **Academic Year 2020-21 (i.e. upto 31<sup>st</sup> May 2021 only)** from the date of joining i.e.11<sup>th</sup> August 2020.
- 3) You will be paid consolidated monthly salary of **Rs. 36,300 Only (Rs Thirty Six Thousand Three Hundred Only)**. No other allowances will be admissible. The salary payment will be subject to statutory deduction of taxes as applicable.
- 4) Your appointment is subject to the minimum numbers of the students and the sufficient workload prescribed for the post.
- 5) Your appointment is on purely temporary basis and will automatically come to an end on the expiry of tenure and in any such event; you shall not claim any right to be continued in the services. You shall not claim to be a regular/permanent employee of the Institute/College. At any time during the tenure of your services or after termination thereof, in any manner whatsoever, and shall not claim automatic re-appointment to the said post after expiry of the tenure of your services and you will not be eligible for any retiral benefits.
- 6) You shall submit the certified true copies of relevant documents such as birth certificate, mark sheets, experience certificates, Approval Letters, reliving certificate, Aadhar Card, PAN card, Last Pay Slip from the previous Employer before joining the duties.
- 7) You will produce 2 passport size recent photographs.
- 8) You are required to give the correct mailing address as soon as you join your duties. It will be presumed that any letter sent by Registered Post Acknowledgement Due (RPAD) or Speed Post or E-Mail on the address given, shall be deemed to have been acknowledged duly signed by you.
- 9) You are entitled Casual Leave as per Rules & Regulation of DYPEECT, subject to changes from time to time.
- 10) You are entitled for Medical Leave only after completion of one-year regular services and as per Rules & Regulation of DYPEECT, subject to changes from time to time.
- 11) If you want to leave the service during the tenure of your appointment, you will have to give one month's notice in writing to the Management. A sum equal to your one months' salary will be deducted or you will need to deposit the same amount to employer in case you resign without serving a one months' notice period. It is desirable that being a teaching faculty, you do not leave the job when the academic session is in progress.
- 12) You will submit to the office the medical fitness certificate from the Registered Medical panel appointed by the DYPEECT before joining your duties.

Page 1 of 2

Received  
D. Y. Patil  
24/08/20

- 13) You will not conduct or engage yourself in private tuitions or private coaching classes.
- 14) You will not engage yourself in any other paid job, full time, part time, honorary or otherwise during the continuance of your service in this Institute/College. You will not undertake any R & D or consultancy work and not register for any degree / diploma / certificate course without approval of the competent authority of the Trust.
- 15) You will not appear for any examinations/Admission without prior permission of the management in service.
- 16) You will not take any active part in the politics, neither involved directly or indirectly in illegal financial matters.
- 17) Your services are transferable within the trust organization only.
- 18) You will not directly or indirectly get yourself involved in any of the anti-activities against the management which may cause any harm to the institute/college or the management.
- 19) Your behavior with colleagues and entire institute/college staff should be polite, co-operative and gentle.
- 20) You will not form any union or organization amongst yourself and colleagues.
- 21) You will not process any letters either signed by you or signed jointly on any issues against the Management/Authorities without prior permission of the Principal/Director. Also, you will not approach to any authorities connected to the Institute/ College / Trust without prior permission of the Principal / Director.
- 22) You will put your grievances to the Management through Principal / Director only.
- 23) You will have to carry out the duties / work assigned to you by the Principal / Director and the Management besides your teaching work / routine work.
- 24) If you found absent continuously for more than 15 days without prior written permission from the Principal/Director, your services will stand terminated automatically and no further correspondence will be entertained thereafter.
- 25) Any information given in the application form if found incorrect contradictory at any time after the appointment, your services will be terminated forthwith, and no further correspondence will be entertained thereafter.
- 26) Progress Report: You will submit your academic progress report and other activities, seminars, presentation of papers, workshop, Self Appraisal etc. twice every year in the months of April and November.
- 27) If it is observed that your performance is not satisfactory / your behavior is not in the interest of the institute or College or trust / you commit breach of terms and conditions as mentioned in your appointment / you are found medically unfit (physically/mentally), your services shall be terminated without giving any notice period.
- 28) You will have to communicate your acceptance in writing to the Management/Director/Principal **within two weeks** from the date of receipt of Order of Appointment, failing which your appointment is liable to be withdrawal / cancelled. However, in case you need an extension of time limit for joining the duties you will have to apply in writing for grant of extension stating the reasons for the same and indicating the date on which you intend to join the duties. The request for grant of extension of time limit for joining the duties for the post shall be considered and you will be informed in the matter. The decision of the management of the **Dr. D Y Patil School of Engineering** shall be final.
- 29) If you are found guilty of violation of any terms & conditions mentioned above you will be liable for disciplinary action and punishment decided by the Management/Director/ Principal as provided in the Rules & Regulations.
- 30) In view of this appointment order, the previous appointment order/s stands cancelled.
- 31) Any dispute arises in the service will be dealt legally in jurisdiction of Pune City only.

*For Dr. D Y Patil Educational Enterprises Charitable Trust*

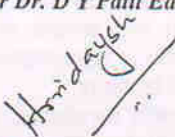
  
**Hridaysh Deshpande**  
**Authorized Signatory**



**Copy to:**

- 1 Master File DYPEECT.
- 2 Principal, Dr. D Y Patil School of Engineering  
(Two Copies: [1] Personal File [2] Accounts Section).
- 3 Chief Financial Officer, DYPEECT.



D Y PATIL GROUP

**Dr. D Y PATIL EDUCATIONAL ENTERPRISES CHARITABLE TRUST**

Ref. ADYPKC/SOE/AO/T/NM/2020-21/ 26

Date: 10.08.2020

To,  
Mr. Nitin Nagesh More,  
Plot No 7 flat no 4  
Rajanigandha Apartment  
Swaraj Nagari  
Talegaon Dabhade: 410506  
Email- nitinmoremech@gmail.com  
Contact-9623402717

**Appointment Order**

**Mr. Nitin Nagesh More,**

Following your application and subsequent interview for the post of **Assistant Professor**, I am pleased to inform you that the Management has appointed you as **Assistant Professor in Mechanical Engineering Department at Dr. D Y Patil School of Engineering**. The terms & conditions of the appointment are as follows.

- 1) Your services are governed by the Maharashtra Universities Act, statutes, ordinances, rules & regulations, code of conduct, laid down by the Savitribai Phule Pune University, Government of Maharashtra and service rules of the Trust and will be responsible to the Principal/Director of the Institute for discharge of your duties.
- 2) Your appointment is on **purely temporary basis** for a period of **Academic Year 2020-21 (i.e. upto 31<sup>st</sup> May 2021 only)** from the date of joining i.e. 10<sup>th</sup> August 2020.
- 3) You will be paid consolidated monthly salary of **Rs. 36,300 Only (Rs Thirty Six Thousand Three Hundred Only)**. No other allowances will be admissible. The salary payment will be subject to statutory deduction of taxes as applicable.
- 4) Your appointment is subject to the minimum numbers of the students and the sufficient workload prescribed for the post.
- 5) Your appointment is on purely temporary basis and will automatically come to an end on the expiry of tenure and in any such event; you shall not claim any right to be continued in the services. You shall not claim to be a regular/permanent employee of the Institute/College. At any time during the tenure of your services or after termination thereof, in any manner whatsoever, and shall not claim automatic re-appointment to the said post after expiry of the tenure of your services and you will not be eligible for any retiral benefits.
- 6) You shall submit the certified true copies of relevant documents such as birth certificate, mark sheets, experience certificates, Approval Letters, reliving certificate, Aadhar Card, PAN card, Last Pay Slip from the previous Employer before joining the duties.
- 7) You will produce 2 passport size recent photographs.
- 8) You are required to give the correct mailing address as soon as you join your duties. It will be presumed that any letter sent by Registered Post Acknowledgement Due (RPAD) or Speed Post or E-Mail on the address given, shall be deemed to have been acknowledged duly signed by you.
- 9) You are entitled Casual Leave as per Rules & Regulation of DYPEECT, subject to changes from time to time.
- 10) You are entitled for Medical Leave only after completion of one-year regular services and as per Rules & Regulation of DYPEECT, subject to changes from time to time.
- 11) If you want to leave the service during the tenure of your appointment, you will have to give one month's notice in writing to the Management. A sum equal to your one months' salary will be deducted or you will need to deposit the same amount to employer in case you resign without serving a one months' notice period. It is desirable that being a teaching faculty, you do not leave the job when the academic session is in progress.
- 12) You will submit to the office the medical fitness certificate from the Registered Medical panel appointed by the DYPEECT before joining your duties.

Page 1 of 2

*Received here*

- 13) You will not conduct or engage yourself in private tuitions or private coaching classes.
- 14) You will not engage yourself in any other paid job, full time, part time, honorary or otherwise during the continuance of your service in this Institute/College. You will not undertake any R & D or consultancy work and not register for any degree / diploma / certificate course without approval of the competent authority of the Trust.
- 15) You will not appear for any examinations/Admission without prior permission of the management in service.
- 16) You will not take any active part in the politics, neither involved directly or indirectly in illegal financial matters.
- 17) Your services are transferable within the trust organization only.
- 18) You will not directly or indirectly get yourself involved in any of the anti-activities against the management which may cause any harm to the institute/college or the management.
- 19) Your behavior with colleagues and entire institute/college staff should be polite, co-operative and gentle.
- 20) You will not form any union or organization amongst yourself and colleagues.
- 21) You will not process any letters either signed by you or signed jointly on any issues against the Management/Authorities without prior permission of the Principal/Director. Also, you will not approach to any authorities connected to the Institute/ College / Trust without prior permission of the Principal / Director.
- 22) You will put your grievances to the Management through Principal / Director only.
- 23) You will have to carry out the duties / work assigned to you by the Principal / Director and the Management besides your teaching work / routine work.
- 24) If you found absent continuously for more than 15 days without prior written permission from the Principal/Director, your services will stand terminated automatically and no further correspondence will be entertained thereafter.
- 25) Any information given in the application form if found incorrect contradictory at any time after the appointment, your services will be terminated forthwith, and no further correspondence will be entertained thereafter.
- 26) Progress Report: You will submit your academic progress report and other activities, seminars, presentation of papers, workshop, Self Appraisal etc. twice every year in the months of April and November.
- 27) If it is observed that your performance is not satisfactory / your behavior is not in the interest of the institute or College or trust / you commit breach of terms and conditions as mentioned in your appointment / you are found medically unfit (physically/mentally), your services shall be terminated without giving any notice period.
- 28) You will have to communicate your acceptance in writing to the Management/Director/Principal **within two weeks** from the date of receipt of Order of Appointment, failing which your appointment is liable to be withdrawal / cancelled. However, in case you need an extension of time limit for joining the duties you will have to apply in writing for grant of extension stating the reasons for the same and indicating the date on which you intend to join the duties. The request for grant of extension of time limit for joining the duties for the post shall be considered and you will be informed in the matter. The decision of the management of the **Dr. D Y Patil School of Engineering** shall be final.
- 29) If you are found guilty of violation of any terms & conditions mentioned above you will be liable for disciplinary action and punishment decided by the Management/Director/ Principal as provided in the Rules & Regulations.
- 30) In view of this appointment order, the previous appointment order/s stands cancelled.
- 31) Any dispute arises in the service will be dealt legally in jurisdiction of Pune City only.

*For Dr. D Y Patil Educational Enterprises Charitable Trust*

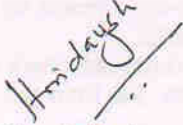
  
**Hrridaysh Deshpande**  
**Authorized Signatory**



**Copy to:**

- 1 Master File DYPECT.
- 2 Principal, Dr. D Y Patil School of Engineering  
(Two Copies: [1] Personal File [2] Accounts Section).
- 3 Chief Financial Officer, DYPECT.



**D Y PATIL GROUP**

**Dr D Y PATIL EDUCATIONAL ENTERPRISES CHARITABLE TRUST**

Ref. ADYPKC/SOE/ME/HK/10082020 / 27

Date: 10.08.2020

To,  
Ms. Himani Kadam,  
C/o Makarand kadam,  
Flat no. 103, A wing,  
Smeha kinara bhau patil road,  
Bopodi, Pune 411020  
Pin : 410506  
Email- himanikadam@gmail.com  
Contact-7719941598

**Appointment Order**

**Ms. Himani Kadam,**

Following your application and subsequent interview for the post of **Assistant Professor**, I am pleased to inform you that the Management has appointed you as **Assistant Professor in Mechanical Engineering Department at Dr. D Y Patil School of Engineering**. The terms & conditions of the appointment are as follows.

- 1) Your services are governed by the Maharashtra Universities Act, statues, ordinances, rules & regulations, code of conduct, laid down by the Savitribai Phule Pune University, Government of Maharashtra and service rules of the Trust and will be responsible to the Principal/Director of the Institute for discharge of your duties.
- 2) Your appointment is on **purely temporary basis** for a period of **Academic Year 2020-21 (i.e. upto 31<sup>st</sup> May 2021 only)** from the date of joining i.e. 10<sup>th</sup> August 2020.
- 3) You will be paid consolidated monthly salary of **Rs. 36,300 Only (Rs Thirty Six Thousand Three Hundred Only)**. No other allowances will be admissible. The salary payment will be subject to statutory deduction of taxes as applicable.
- 4) Your appointment is subject to the minimum numbers of the students and the sufficient workload prescribed for the post.
- 5) Your appointment is on purely temporary basis and will automatically come to an end on the expiry of tenure and in any such event; you shall not claim any right to be continued in the services. You shall not claim to be a regular/permanent employee of the Institute/College. At any time during the tenure of your services or after termination thereof, in any manner whatsoever, and shall not claim automatic re-appointment to the said post after expiry of the tenure of your services and you will not be eligible for any retiral benefits.
- 6) You shall submit the certified true copies of relevant documents such as birth certificate, mark sheets, experience certificates, Approval Letters, reliving certificate, Aadhar Card, PAN card, Last Pay Slip from the previous Employer before joining the duties.
- 7) You will produce 2 passport size recent photographs.
- 8) You are required to give the correct mailing address as soon as you join your duties. It will be presumed that any letter sent by Registered Post Acknowledgement Due (RPAD) or Speed Post or E-Mail on the address given, shall be deemed to have been acknowledged duly signed by you.
- 9) You are entitled Casual Leave as per Rules & Regulation of DYPEECT, subject to changes from time to time.
- 10) You are entitled for Medical Leave only after completion of one-year regular services and as per Rules & Regulation of DYPEECT, subject to changes from time to time.
- 11) If you want to leave the service during the tenure of your appointment, you will have to give one month's notice in writing to the Management. A sum equal to your one months' salary will be deducted or you will need to deposit the same amount to employer in case you resign without serving a one months' notice period. It is desirable that being a teaching faculty, you do not leave the job when the academic session is in progress.
- 12) You will submit to the office the medical fitness certificate from the Registered Medical panel appointed by the DYPEECT before joining your duties.

Page 1 of 2

Received  
H Kadam  
26/08/2020

- 13) You will not conduct or engage yourself in private tuitions or private coaching classes.
- 14) You will not engage yourself in any other paid job, full time, part time, honorary or otherwise during the continuance of your service in this Institute/College. You will not undertake any R & D or consultancy work and not register for any degree / diploma / certificate course without approval of the competent authority of the Trust.
- 15) You will not appear for any examinations/Admission without prior permission of the management in service.
- 16) You will not take any active part in the politics, neither involved directly or indirectly in illegal financial matters.
- 17) Your services are transferable within the trust organization only.
- 18) You will not directly or indirectly get yourself involved in any of the anti-activities against the management which may cause any harm to the institute/college or the management.
- 19) Your behavior with colleagues and entire institute/college staff should be polite, co-operative and gentle.
- 20) You will not form any union or organization amongst yourself and colleagues.
- 21) You will not process any letters either signed by you or signed jointly on any issues against the Management/Authorities without prior permission of the Principal/Director. Also, you will not approach to any authorities connected to the Institute/ College / Trust without prior permission of the Principal / Director.
- 22) You will put your grievances to the Management through Principal / Director only.
- 23) You will have to carry out the duties / work assigned to you by the Principal / Director and the Management besides your teaching work / routine work.
- 24) If you found absent continuously for more than 15 days without prior written permission from the Principal/Director, your services will stand terminated automatically and no further correspondence will be entertained thereafter.
- 25) Any information given in the application form if found incorrect contradictory at any time after the appointment, your services will be terminated forthwith, and no further correspondence will be entertained thereafter.
- 26) Progress Report: You will submit your academic progress report and other activities, seminars, presentation of papers, workshop, Self Appraisal etc. twice every year in the months of April and November.
- 27) If it is observed that your performance is not satisfactory / your behavior is not in the interest of the institute or College or trust / you commit breach of terms and conditions as mentioned in your appointment / you are found medically unfit (physically/mentally), your services shall be terminated without giving any notice period.
- 28) You will have to communicate your acceptance in writing to the Management/Director/Principal **within two weeks** from the date of receipt of Order of Appointment, failing which your appointment is liable to be withdrawal / cancelled. However, in case you need an extension of time limit for joining the duties you will have to apply in writing for grant of extension stating the reasons for the same and indicating the date on which you intend to join the duties. The request for grant of extension of time limit for joining the duties for the post shall be considered and you will be informed in the matter. The decision of the management of the **Dr. D Y Patil School of Engineering** shall be final.
- 29) If you are found guilty of violation of any terms & conditions mentioned above you will be liable for disciplinary action and punishment decided by the Management/Director/ Principal as provided in the Rules & Regulations.
- 30) In view of this appointment order, the previous appointment order/s stands cancelled.
- 31) Any dispute arises in the service will be dealt legally in jurisdiction of Pune City only.

*For Dr. D Y Patil Educational Enterprises Charitable Trust*

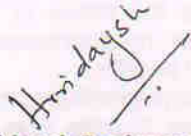
  
**Hridaysh Deshpande**  
**Authorized Signatory**



**Copy to:**

- 1 Master File DYPEECT.
- 2 Principal, Dr. D Y Patil School of Engineering  
(Two Copies: [1] Personal File [2] Accounts Section).
- 3 Chief Financial Officer, DYPEECT.



D Y PATIL GROUP

**Dr D Y PATIL EDUCATIONAL ENTERPRISES CHARITABLE TRUST**

Ref.ADYPKC/SOE/AO/T/KM/2020-21/ 28

Date: 10.08.2020

To,  
Mr. Kunal Shriramprakash. Marathe,  
Lane No 6,  
Ganeshnager Sangamaner,  
Dist- Ahmednagar  
Pin- 422605  
Email- marathekunals@gmail.com  
Contact-9970950964

**Appointment Order**

**Mr. Kunal Shriramprakash. Marathe,**

Following your application and subsequent interview for the post of **Assistant Professor**, I am pleased to inform you that the Management has appointed you as **Assistant Professor in Mechanical Engineering Department at Dr. D Y Patil School of Engineering**. The terms & conditions of the appointment are as follows.

- 1) Your services are governed by the Maharashtra Universities Act, statues, ordinances, rules & regulations, code of conduct, laid down by the Savitribai Phule Pune University, Government of Maharashtra and service rules of the Trust and will be responsible to the Principal/Director of the Institute for discharge of your duties.
- 2) Your appointment is on **purely temporary basis** for a period of **Academic Year 2020-21 (i.e. upto 31<sup>st</sup> May 2021 only)** from the date of joining i.e.10<sup>th</sup> August 2020.
- 3) You will be paid consolidated monthly salary of **Rs. 45,000 Only (Rs Forty Five Thousand Only)**. No other allowances will be admissible. The salary payment will be subject to statutory deduction of taxes as applicable.
- 4) Your appointment is subject to the minimum numbers of the students and the sufficient workload prescribed for the post.
- 5) Your appointment is on purely temporary basis and will automatically come to an end on the expiry of tenure and in any such event; you shall not claim any right to be continued in the services. You shall not claim to be a regular/permanent employee of the Institute/College. At any time during the tenure of your services or after termination thereof, in any manner whatsoever, and shall not claim automatic re-appointment to the said post after expiry of the tenure of your services and you will not be eligible for any retiral benefits.
- 6) You shall submit the certified true copies of relevant documents such as birth certificate, mark sheets, experience certificates, Approval Letters, reliving certificate, Aadhar Card, PAN card, Last Pay Slip from the previous Employer before joining the duties.
- 7) You will produce 2 passport size recent photographs.
- 8) You are required to give the correct mailing address as soon as you join your duties. It will be presumed that any letter sent by Registered Post Acknowledgement Due (RPAD) or Speed Post or E-Mail on the address given, shall be deemed to have been acknowledged duly signed by you.
- 9) You are entitled Casual Leave as per Rules & Regulation of DYPEECT, subject to changes from time to time.
- 10) You are entitled for Medical Leave only after completion of one-year regular services and as per Rules & Regulation of DYPEECT, subject to changes from time to time.
- 11) If you want to leave the service during the tenure of your appointment, you will have to give one month's notice in writing to the Management. A sum equal to your one months' salary will be deducted or you will need to deposit the same amount to employer in case you resign without serving a one months' notice period. It is desirable that being a teaching faculty, you do not leave the job when the academic session is in progress.
- 12) You will submit to the office the medical fitness certificate from the Registered Medical panel appointed by the DYPEECT before joining your duties.

Page 1 of 2

Received  
Kamini  
26.08.2020



- 13) You will not conduct or engage yourself in private tuitions or private coaching classes.
- 14) You will not engage yourself in any other paid job, full time, part time, honorary or otherwise during the continuance of your service in this Institute/College. You will not undertake any R & D or consultancy work and not register for any degree / diploma / certificate course without approval of the competent authority of the Trust.
- 15) You will not appear for any examinations/Admission without prior permission of the management in service.
- 16) You will not take any active part in the politics, neither involved directly or indirectly in illegal financial matters.
- 17) Your services are transferable within the trust organization only.
- 18) You will not directly or indirectly get yourself involved in any of the anti-activities against the management which may cause any harm to the institute/college or the management.
- 19) Your behavior with colleagues and entire institute/college staff should be polite, co-operative and gentle.
- 20) You will not form any union or organization amongst yourself and colleagues.
- 21) You will not process any letters either signed by you or signed jointly on any issues against the Management/Authorities without prior permission of the Principal/Director. Also, you will not approach to any authorities connected to the Institute/ College / Trust without prior permission of the Principal / Director.
- 22) You will put your grievances to the Management through Principal / Director only.
- 23) You will have to carry out the duties / work assigned to you by the Principal / Director and the Management besides your teaching work / routine work.
- 24) If you found absent continuously for more than 15 days without prior written permission from the Principal/Director, your services will stand terminated automatically and no further correspondence will be entertained thereafter.
- 25) Any information given in the application form if found incorrect contradictory at any time after the appointment, your services will be terminated forthwith, and no further correspondence will be entertained thereafter.
- 26) Progress Report: You will submit your academic progress report and other activities, seminars, presentation of papers, workshop, Self Appraisal etc. twice every year in the months of April and November.
- 27) If it is observed that your performance is not satisfactory / your behavior is not in the interest of the institute or College or trust / you commit breach of terms and conditions as mentioned in your appointment / you are found medically unfit (physically/mentally), your services shall be terminated without giving any notice period.
- 28) You will have to communicate your acceptance in writing to the Management/Director/Principal **within two weeks** from the date of receipt of Order of Appointment, failing which your appointment is liable to be withdrawal / cancelled. However, in case you need an extension of time limit for joining the duties you will have to apply in writing for grant of extension stating the reasons for the same and indicating the date on which you intend to join the duties. The request for grant of extension of time limit for joining the duties for the post shall be considered and you will be informed in the matter. The decision of the management of the **Dr. D Y Patil School of Engineering** shall be final.
- 29) If you are found guilty of violation of any terms & conditions mentioned above you will be liable for disciplinary action and punishment decided by the Management/Director/ Principal as provided in the Rules & Regulations.
- 30) In view of this appointment order, the previous appointment order/s stands cancelled.
- 31) Any dispute arises in the service will be dealt legally in jurisdiction of Pune City only.

*For Dr. D Y Patil Educational Enterprises Charitable Trust*

*Hrridaysh*  
**Hrridaysh Deshpande**  
**Authorized Signatory**

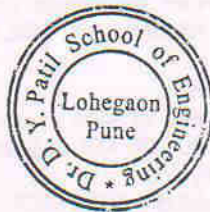

**Copy to:**

- 1 Master File DYPEECT.
- 2 Principal, Dr. D Y Patil School of Engineering  
(Two Copies: [1] Personal File [2] Accounts Section).
- 3 Chief Financial Officer, DYPEECT.



**D Y PATIL GROUP**

Ref. ADYPKC/SOE/AO/T/VT/2020-21/29 Date: 17.08.2020

REF. ADYPKC/SOE/AO/T/VT/2020-21/29

Date-17/08/20

To,  
**Mr. Vinod D. Tirpude,**  
Near Government Polytechnic,  
Bhaipur Tai- Arvi,  
Dist- Wardha  
Email- tirpudev@gmail.com  
Contact-9511675554

### Appointment Order

**Mr. Vinod D. Tirpude,**

Following your application and subsequent interview for the post of **Assistant Professor**, I am pleased to inform you that the Management has appointed you as **Assistant Professor in Mechanical Engineering Department at Dr. D Y Patil School of Engineering**. The terms & conditions of the appointment are as follows.

- 1) Your services are governed by the Maharashtra Universities Act, statues, ordinances, rules & regulations, code of conduct, laid down by the Savitribai Phule Pune University, Government of Maharashtra and service rules of the Trust and will be responsible to the Principal/Director of the Institute for discharge of your duties.
- 2) Your appointment is on **purely temporary basis** for a period of **Academic Year 2020-21 (i.e. upto 31<sup>st</sup> May 2021 only)** from the date of joining i.e. 17<sup>th</sup> August 2020.
- 3) You will be paid consolidated monthly salary of **Rs. 38,900 Only (Rs Thirty Eight Thousand Nine hundred Only)**. No other allowances will be admissible. The salary payment will be subject to statutory deduction of taxes as applicable.
- 4) Your appointment is subject to the minimum numbers of the students and the sufficient workload prescribed for the post.
- 5) Your appointment is on purely temporary basis and will automatically come to an end on the expiry of tenure and in any such event; you shall not claim any right to be continued in the services. You shall not claim to be a regular/permanent employee of the Institute/College. At any time during the tenure of your services or after termination thereof, in any manner whatsoever, and shall not claim automatic re-appointment to the said post after expiry of the tenure of your services and you will not be eligible for any retiral benefits.
- 6) You shall submit the certified true copies of relevant documents such as birth certificate, mark sheets, experience certificates, Approval Letters, reliving certificate, Aadhar Card, PAN card, Last Pay Slip from the previous Employer before joining the duties.
- 7) You will produce 2 passport size recent photographs.
- 8) You are required to give the correct mailing address as soon as you join your duties. It will be presumed that any letter sent by Registered Post Acknowledgement Due (RPAD) or Speed Post or E-Mail on the address given, shall be deemed to have been acknowledged duly signed by you.
- 9) You are entitled Casual Leave as per Rules & Regulation of DYPEECT, subject to changes from time to time.
- 10) You are entitled for Medical Leave only after completion of one-year regular services and as per Rules & Regulation of DYPEECT, subject to changes from time to time.
- 11) If you want to leave the service during the tenure of your appointment, you will have to give one month's notice in writing to the Management. A sum equal to your one months' salary will be deducted or you will need to deposit the same amount to employer in case you resign without serving a one months' notice period. It is desirable that being a teaching faculty, you do not leave the job when the academic session is in progress.
- 12) You will submit to the office the medical fitness certificate from the Registered Medical panel appointed by the DYPEECT before joining your duties.

Received  
D  
25/8/20

Page 1 of 2

- 13) You will not conduct or engage yourself in private tuitions or private coaching classes.
- 14) You will not engage yourself in any other paid job, full time, part time, honorary or otherwise during the continuance of your service in this Institute/College. You will not undertake any R & D or consultancy work and not register for any degree / diploma / certificate course without approval of the competent authority of the Trust.
- 15) You will not appear for any examinations/Admission without prior permission of the management in service.
- 16) You will not take any active part in the politics, neither involved directly or indirectly in illegal financial matters.
- 17) Your services are transferable within the trust organization only.
- 18) You will not directly or indirectly get yourself involved in any of the anti-activities against the management which may cause any harm to the institute/college or the management.
- 19) Your behavior with colleagues and entire institute/college staff should be polite, co-operative and gentle.
- 20) You will not form any union or organization amongst yourself and colleagues.
- 21) You will not process any letters either signed by you or signed jointly on any issues against the Management/Authorities without prior permission of the Principal/Director. Also, you will not approach to any authorities connected to the Institute/ College / Trust without prior permission of the Principal / Director.
- 22) You will put your grievances to the Management through Principal / Director only.
- 23) You will have to carry out the duties / work assigned to you by the Principal / Director and the Management besides your teaching work / routine work.
- 24) If you found absent continuously for more than 15 days without prior written permission from the Principal/Director, your services will stand terminated automatically and no further correspondence will be entertained thereafter.
- 25) Any information given in the application form if found incorrect contradictory at any time after the appointment, your services will be terminated forthwith, and no further correspondence will be entertained thereafter.
- 26) Progress Report: You will submit your academic progress report and other activities, seminars, presentation of papers, workshop, Self Appraisal etc. twice every year in the months of April and November.
- 27) If it is observed that your performance is not satisfactory / your behavior is not in the interest of the institute or College or trust / you commit breach of terms and conditions as mentioned in your appointment / you are found medically unfit (physically/mentally), your services shall be terminated without giving any notice period.
- 28) You will have to communicate your acceptance in writing to the Management/Director/Principal **within two weeks** from the date of receipt of Order of Appointment, failing which your appointment is liable to be withdrawal / cancelled. However, in case you need an extension of time limit for joining the duties you will have to apply in writing for grant of extension stating the reasons for the same and indicating the date on which you intend to join the duties. The request for grant of extension of time limit for joining the duties for the post shall be considered and you will be informed in the matter. The decision of the management of the **Dr. D Y Patil School of Engineering** shall be final.
- 29) If you are found guilty of violation of any terms & conditions mentioned above you will be liable for disciplinary action and punishment decided by the Management/Director/ Principal as provided in the Rules & Regulations.
- 30) In view of this appointment order, the previous appointment order/s stands cancelled.
- 31) Any dispute arises in the service will be dealt legally in jurisdiction of Pune City only.

*For Dr. D Y Patil Educational Enterprises Charitable Trust*

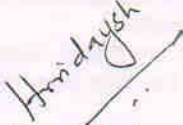
  
**Hrridaysh Deshpande**  
**Authorized Signatory**



**Copy to:**

- 1 Master File DYPEECT.
- 2 Principal, Dr. D Y Patil School of Engineering  
(Two Copies: [1] Personal File [2] Accounts Section).
- 3 Chief Financial Officer, DYPEECT.



D Y PATIL GROUP

**Dr D Y PATIL EDUCATIONAL ENTERPRISES CHARITABLE TRUST**

Ref.ADYPKC/SOE/AO/T/DS/2020-21/ 30

Date: 10.08.2020

To,  
Mr. Dipak Dnyandeo Shelke,  
A/p- Chas, Taluka- Akole,  
Dist. Ahmednagar,  
422610  
Email- shelkedipak92@gmail.com  
Contact-9511675554

**Appointment Order**

**Mr. Dipak Dnyandeo Shelke,**

Following your application and subsequent interview for the post of **Assistant Professor**, I am pleased to inform you that the Management has appointed you as **Assistant Professor in Mechanical Engineering Department at Dr. D Y Patil School of Engineering**. The terms & conditions of the appointment are as follows.

- 1) Your services are governed by the Maharashtra Universities Act, statues, ordinances, rules & regulations, code of conduct, laid down by the Savitribai Phule Pune University, Government of Maharashtra and service rules of the Trust and will be responsible to the Principal/Director of the Institute for discharge of your duties.
- 2) Your appointment is on **purely temporary basis** for a period of **Academic Year 2020-21 (i.e. upto 31<sup>st</sup> May 2021 only)** from the date of joining i.e.10<sup>th</sup> August 2020.
- 3) You will be paid consolidated monthly salary **of Rs. 35,000 Only (Rs Thirty Five Thousand Only)**. No other allowances will be admissible. The salary payment will be subject to statutory deduction of taxes as applicable.
- 4) Your appointment is subject to the minimum numbers of the students and the sufficient workload prescribed for the post.
- 5) Your appointment is on purely temporary basis and will automatically come to an end on the expiry of tenure and in any such event; you shall not claim any right to be continued in the services. You shall not claim to be a regular/permanent employee of the Institute/College. At any time during the tenure of your services or after termination thereof, in any manner whatsoever, and shall not claim automatic re-appointment to the said post after expiry of the tenure of your services and you will not be eligible for any retiral benefits.
- 6) You shall submit the certified true copies of relevant documents such as birth certificate, mark sheets, experience certificates, Approval Letters, reliving certificate, Aadhar Card, PAN card, Last Pay Slip from the previous Employer before joining the duties.
- 7) You will produce 2 passport size recent photographs.
- 8) You are required to give the correct mailing address as soon as you join your duties. It will be presumed that any letter sent by Registered Post Acknowledgement Due (RPAD) or Speed Post or E-Mail on the address given, shall be deemed to have been acknowledged duly signed by you.
- 9) You are entitled Casual Leave as per Rules & Regulation of DYPEECT, subject to changes from time to time.
- 10) You are entitled for Medical Leave only after completion of one-year regular services and as per Rules & Regulation of DYPEECT, subject to changes from time to time.
- 11) If you want to leave the service during the tenure of your appointment, you will have to give one month's notice in writing to the Management. A sum equal to your one months' salary will be deducted or you will need to deposit the same amount to employer in case you resign without serving a one months' notice period. It is desirable that being a teaching faculty, you do not leave the job when the academic session is in progress.
- 12) You will submit to the office the medical fitness certificate from the Registered Medical panel appointed by the DYPEECT before joining your duties.

*Revised  
Patil  
28/8/20*

Page 1 of 2

- 13) You will not conduct or engage yourself in private tuitions or private coaching classes.
- 14) You will not engage yourself in any other paid job, full time, part time, honorary or otherwise during the continuance of your service in this Institute/College. You will not undertake any R & D or consultancy work and not register for any degree / diploma / certificate course without approval of the competent authority of the Trust.
- 15) You will not appear for any examinations/Admission without prior permission of the management in service.
- 16) You will not take any active part in the politics, neither involved directly or indirectly in illegal financial matters.
- 17) Your services are transferable within the trust organization only.
- 18) You will not directly or indirectly get yourself involved in any of the anti-activities against the management which may cause any harm to the institute/college or the management.
- 19) Your behavior with colleagues and entire institute/college staff should be polite, co-operative and gentle.
- 20) You will not form any union or organization amongst yourself and colleagues.
- 21) You will not process any letters either signed by you or signed jointly on any issues against the Management/Authorities without prior permission of the Principal/Director. Also, you will not approach to any authorities connected to the Institute/ College / Trust without prior permission of the Principal / Director.
- 22) You will put your grievances to the Management through Principal / Director only.
- 23) You will have to carry out the duties / work assigned to you by the Principal / Director and the Management besides your teaching work / routine work.
- 24) If you found absent continuously for more than 15 days without prior written permission from the Principal/Director, your services will stand terminated automatically and no further correspondence will be entertained thereafter.
- 25) Any information given in the application form if found incorrect contradictory at any time after the appointment, your services will be terminated forthwith, and no further correspondence will be entertained thereafter.
- 26) Progress Report: You will submit your academic progress report and other activities, seminars, presentation of papers, workshop, Self Appraisal etc. twice every year in the months of April and November.
- 27) If it is observed that your performance is not satisfactory / your behavior is not in the interest of the institute or College or trust / you commit breach of terms and conditions as mentioned in your appointment / you are found medically unfit (physically/mentally), your services shall be terminated without giving any notice period.
- 28) You will have to communicate your acceptance in writing to the Management/Director/Principal **within two weeks** from the date of receipt of Order of Appointment, failing which your appointment is liable to be withdrawal / cancelled. However, in case you need an extension of time limit for joining the duties you will have to apply in writing for grant of extension stating the reasons for the same and indicating the date on which you intend to join the duties. The request for grant of extension of time limit for joining the duties for the post shall be considered and you will be informed in the matter. The decision of the management of the **Dr. D Y Patil School of Engineering** shall be final.
- 29) If you are found guilty of violation of any terms & conditions mentioned above you will be liable for disciplinary action and punishment decided by the Management/Director/ Principal as provided in the Rules & Regulations.
- 30) In view of this appointment order, the previous appointment order/s stands cancelled.
- 31) Any dispute arises in the service will be dealt legally in jurisdiction of Pune City only.

*For Dr. D Y Patil Educational Enterprises Charitable Trust*

*Hridaysh*  
**Hridaysh Deshpande**  
**Authorized Signatory**



**Copy to:**

- 1 Master File DYPEECT.
- 2 Principal, Dr. D Y Patil School of Engineering  
(Two Copies: [1] Personal File [2] Accounts Section).
- 3 Chief Financial Officer, DYPEECT.



## Dr D Y PATIL EDUCATIONAL ENTERPRISES CHARITABLE TRUST

Ref.ADYPKC/SOE/AO/T/AA/2020-21/31

Date: 17.08.2020

To,  
Mr. Ansari Md Awes,  
Flat No 18,  
Classic Mita Nagar  
Pune-48  
Email- ansariawes@gmail.com  
Contact-8087379855

### Appointment Order

**Mr. Ansari Md Awes**

Following your application and subsequent interview for the post of **Assistant Professor**, I am pleased to inform you that the Management has appointed you as **Assistant Professor in Mechanical Engineering Department at Dr. D Y Patil School of Engineering**. The terms & conditions of the appointment are as follows.

- 1) Your services are governed by the Maharashtra Universities Act, statues, ordinances, rules & regulations, code of conduct, laid down by the Savitribai Phule Pune University, Government of Maharashtra and service rules of the Trust and will be responsible to the Principal/Director of the Institute for discharge of your duties.
- 2) Your appointment is on **purely temporary basis** for a period of **Academic Year 2020-21 (i.e. upto 31<sup>st</sup> May 2021 only)** from the date of joining i.e.17<sup>th</sup>August 2020.
- 3) You will be paid consolidated monthly salary of **Rs. 35,000 Only (Rs Thirty Five Thousand Only)**. No other allowances will be admissible. The salary payment will be subject to statutory deduction of taxes as applicable.
- 4) Your appointment is subject to the minimum numbers of the students and the sufficient workload prescribed for the post.
- 5) Your appointment is on purely temporary basis and will automatically come to an end on the expiry of tenure and in any such event; you shall not claim any right to be continued in the services. You shall not claim to be a regular/permanent employee of the Institute/College. At any time during the tenure of your services or after termination thereof, in any manner whatsoever, and shall not claim automatic re-appointment to the said post after expiry of the tenure of your services and you will not be eligible for any retiral benefits.
- 6) You shall submit the certified true copies of relevant documents such as birth certificate, mark sheets, experience certificates, Approval Letters, reliving certificate, Aadhar Card, PAN card, Last Pay Slip from the previous Employer before joining the duties.
- 7) You will produce 2 passport size recent photographs.
- 8) You are required to give the correct mailing address as soon as you join your duties. It will be presumed that any letter sent by Registered Post Acknowledgement Due (RPAD) or Speed Post or E-Mail on the address given, shall be deemed to have been acknowledged duly signed by you.
- 9) You are entitled Casual Leave as per Rules & Regulation of DYPEECT, subject to changes from time to time.
- 10) You are entitled for Medical Leave only after completion of one-year regular services and as per Rules & Regulation of DYPEECT, subject to changes from time to time.
- 11) If you want to leave the service during the tenure of your appointment, you will have to give one month's notice in writing to the Management. A sum equal to your one months' salary will be deducted or you will need to deposit the same amount to employer in case you resign without serving a one months' notice period. It is desirable that being a teaching faculty, you do not leave the job when the academic session is in progress.
- 12) You will submit to the office the medical fitness certificate from the Registered Medical panel appointed by the DYPEECT before joining your duties.

Page 1 of 2

Received

3/16  
28/08/20

- 13) You will not conduct or engage yourself in private tuitions or private coaching classes.
- 14) You will not engage yourself in any other paid job, full time, part time, honorary or otherwise during the continuance of your service in this Institute/College. You will not undertake any R & D or consultancy work and not register for any degree / diploma / certificate course without approval of the competent authority of the Trust.
- 15) You will not appear for any examinations/Admission without prior permission of the management in service.
- 16) You will not take any active part in the politics, neither involved directly or indirectly in illegal financial matters.
- 17) Your services are transferable within the trust organization only.
- 18) You will not directly or indirectly get yourself involved in any of the anti-activities against the management which may cause any harm to the institute/college or the management.
- 19) Your behavior with colleagues and entire institute/college staff should be polite, co-operative and gentle.
- 20) You will not form any union or organization amongst yourself and colleagues.
- 21) You will not process any letters either signed by you or signed jointly on any issues against the Management/Authorities without prior permission of the Principal/Director. Also, you will not approach to any authorities connected to the Institute/ College / Trust without prior permission of the Principal / Director.
- 22) You will put your grievances to the Management through Principal / Director only.
- 23) You will have to carry out the duties / work assigned to you by the Principal / Director and the Management besides your teaching work / routine work.
- 24) If you found absent continuously for more than 15 days without prior written permission from the Principal/Director, your services will stand terminated automatically and no further correspondence will be entertained thereafter.
- 25) Any information given in the application form if found incorrect contradictory at any time after the appointment, your services will be terminated forthwith, and no further correspondence will be entertained thereafter.
- 26) Progress Report: You will submit your academic progress report and other activities, seminars, presentation of papers, workshop, Self Appraisal etc. twice every year in the months of April and November.
- 27) If it is observed that your performance is not satisfactory / your behavior is not in the interest of the institute or College or trust / you commit breach of terms and conditions as mentioned in your appointment / you are found medically unfit (physically/mentally), your services shall be terminated without giving any notice period.
- 28) You will have to communicate your acceptance in writing to the Management/Director/Principal **within two weeks** from the date of receipt of Order of Appointment, failing which your appointment is liable to be withdrawal / cancelled. However, in case you need an extension of time limit for joining the duties you will have to apply in writing for grant of extension stating the reasons for the same and indicating the date on which you intend to join the duties. The request for grant of extension of time limit for joining the duties for the post shall be considered and you will be informed in the matter. The decision of the management of the **Dr. D Y Patil School of Engineering** shall be final.
- 29) If you are found guilty of violation of any terms & conditions mentioned above you will be liable for disciplinary action and punishment decided by the Management/Director/ Principal as provided in the Rules & Regulations.
- 30) In view of this appointment order, the previous appointment order/s stands cancelled.
- 31) Any dispute arises in the service will be dealt legally in jurisdiction of Pune City only.

*For Dr. D Y Patil Educational Enterprises Charitable Trust*

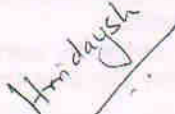
  
**Hrridaysh Deshpande**  
**Authorized Signatory**



**Copy to:**

- 1 Master File DYPEECT.
- 2 Principal, Dr. D Y Patil School of Engineering  
(Two Copies: [1] Personal File [2] Accounts Section).
- 3 Chief Financial Officer, DYPEECT.



**D Y PATIL GROUP**

**Dr D Y PATIL EDUCATIONAL ENTERPRISES CHARITABLE TRUST**

Ref. ADYPKC/SOE/AO/T/KK/2020-21/ 32

Date: 25.08.2020

To,  
Mr. Kundan Suresh Kolambe,  
Sai Leela Society,  
Flat No-A/404,  
Beside Devarshi, Complex  
Manaji Nagar,  
Narhe Pune-411041  
Email:-[kundankolambe@rediffmail.com](mailto:kundankolambe@rediffmail.com)  
Contact: - 9158868787

**Appointment Order**

**Mr. Kundan Suresh Kolambe,**

Following your application and subsequent interview for the post of **Assistant Professor**, I am pleased to inform you that the Management has appointed you as **Assistant Professor in Mechanical Engineering Department at Dr. D Y Patil School of Engineering**. The terms & conditions of the appointment are as follows.

- 1) Your services are governed by the Maharashtra Universities Act, statues, ordinances, rules & regulations, code of conduct, laid down by the Savitribai Phule Pune University, Government of Maharashtra and service rules of the Trust and will be responsible to the Principal/Director of the Institute for discharge of your duties.
- 2) Your appointment is on **purely temporary basis** for a period of **Academic Year 2020-21 (i.e. upto 31<sup>st</sup> May 2021 only)** from the date of joining i.e. 25<sup>th</sup> August 2020.
- 3) You will be paid consolidated monthly salary of **Rs. 35,000 Only (Rs Thirty Five Thousand Only)**. No other allowances will be admissible. The salary payment will be subject to statutory deduction of taxes as applicable.
- 4) Your appointment is subject to the minimum numbers of the students and the sufficient workload prescribed for the post.
- 5) Your appointment is on purely temporary basis and will automatically come to an end on the expiry of tenure and in any such event; you shall not claim any right to be continued in the services. You shall not claim to be a regular/permanent employee of the Institute/College. At any time during the tenure of your services or after termination thereof, in any manner whatsoever, and shall not claim automatic re-appointment to the said post after expiry of the tenure of your services and you will not be eligible for any retiral benefits.
- 6) You shall submit the certified true copies of relevant documents such as birth certificate, mark sheets, experience certificates, Approval Letters, reliving certificate, Aadhar Card, PAN card, Last Pay Slip from the previous Employer before joining the duties.
- 7) You will produce 2 passport size recent photographs.
- 8) You are required to give the correct mailing address as soon as you join your duties. It will be presumed that any letter sent by Registered Post Acknowledgement Due (RPAD) or Speed Post or E-Mail on the address given, shall be deemed to have been acknowledged duly signed by you.
- 9) You are entitled Casual Leave as per Rules & Regulation of DYPEECT, subject to changes from time to time.
- 10) You are entitled for Medical Leave only after completion of one-year regular services and as per Rules & Regulation of DYPEECT, subject to changes from time to time.
- 11) If you want to leave the service during the tenure of your appointment, you will have to give one month's notice in writing to the Management. A sum equal to your one months' salary will be deducted or you will need to deposit the same amount to employer in case you resign without serving a one months' notice period. It is desirable that being a teaching faculty, you do not leave the job when the academic session is in progress.
- 12) You will submit to the office the medical fitness certificate from the Registered Medical panel appointed by the DYPEECT before joining your duties.

Sky 25/08/2020 Page 1 of 2

Received







D Y PATIL GROUP

Dr D Y PATIL EDUCATIONAL ENTERPRISES CHARITABLE TRUST

Ref.ADYPKC/SOE/AO/T/AB/2020-21/ 33

Date: 24.08.2020

To,  
Mr. Anil L Bavche,  
C/O: Swapnaputty Society,  
Survey No 32/1K/3/ Shelar Mala  
Pin-411046  
Email- anilbavche1800@gmail.com  
Contact-8329137246

Appointment Order

Mr. Anil L Bavche,

Following your application and subsequent interview for the post of **Assistant Professor**, I am pleased to inform you that the Management has appointed you as **Assistant Professor in Mechanical Engineering Department at Dr. D Y Patil School of Engineering**. The terms & conditions of the appointment are as follows.

- 1) Your services are governed by the Maharashtra Universities Act, statutes, ordinances, rules & regulations, code of conduct, laid down by the Savitribai Phule Pune University, Government of Maharashtra and service rules of the Trust and will be responsible to the Principal/Director of the Institute for discharge of your duties.
- 2) Your appointment is on **purely temporary basis** for a period of **Academic Year 2020-21 (i.e. upto 31<sup>st</sup> May 2021 only)** from the date of joining i.e. 24<sup>th</sup> August 2020.
- 3) You will be paid consolidated monthly salary of **Rs. 35,000 Only (Rs Thirty Five Thousand Only)**. No other allowances will be admissible. The salary payment will be subject to statutory deduction of taxes as applicable.
- 4) Your appointment is subject to the minimum numbers of the students and the sufficient workload prescribed for the post.
- 5) Your appointment is on purely temporary basis and will automatically come to an end on the expiry of tenure and in any such event; you shall not claim any right to be continued in the services. You shall not claim to be a regular/permanent employee of the Institute/College. At any time during the tenure of your services or after termination thereof, in any manner whatsoever, and shall not claim automatic re-appointment to the said post after expiry of the tenure of your services and you will not be eligible for any retiral benefits.
- 6) You shall submit the certified true copies of relevant documents such as birth certificate, mark sheets, experience certificates, Approval Letters, reliving certificate, Aadhar Card, PAN card, Last Pay Slip from the previous Employer before joining the duties.
- 7) You will produce 2 passport size recent photographs.
- 8) You are required to give the correct mailing address as soon as you join your duties. It will be presumed that any letter sent by Registered Post Acknowledgement Due (RPAD) or Speed Post or E-Mail on the address given, shall be deemed to have been acknowledged duly signed by you.
- 9) You are entitled Casual Leave as per Rules & Regulation of DYPEECT, subject to changes from time to time.
- 10) You are entitled for Medical Leave only after completion of one-year regular services and as per Rules & Regulation of DYPEECT, subject to changes from time to time.
- 11) If you want to leave the service during the tenure of your appointment, you will have to give one month's notice in writing to the Management. A sum equal to your one months' salary will be deducted or you will need to deposit the same amount to employer in case you resign without serving a one months' notice period. It is desirable that being a teaching faculty, you do not leave the job when the academic session is in progress.
- 12) You will submit to the office the medical fitness certificate from the Registered Medical panel appointed by the DYPEECT before joining your duties.

Page 1 of 2

*Handwritten signature and date:*  
21/08/2020

- 13) You will not conduct or engage yourself in private tuitions or private coaching classes.
- 14) You will not engage yourself in any other paid job, full time, part time, honorary or otherwise during the continuance of your service in this Institute/College. You will not undertake any R & D or consultancy work and not register for any degree / diploma / certificate course without approval of the competent authority of the Trust.
- 15) You will not appear for any examinations/Admission without prior permission of the management in service.
- 16) You will not take any active part in the politics, neither involved directly or indirectly in illegal financial matters.
- 17) Your services are transferable within the trust organization only.
- 18) You will not directly or indirectly get yourself involved in any of the anti-activities against the management which may cause any harm to the institute/college or the management.
- 19) Your behavior with colleagues and entire institute/college staff should be polite, co-operative and gentle.
- 20) You will not form any union or organization amongst yourself and colleagues.
- 21) You will not process any letters either signed by you or signed jointly on any issues against the Management/Authorities without prior permission of the Principal/Director. Also, you will not approach to any authorities connected to the Institute/ College / Trust without prior permission of the Principal / Director.
- 22) You will put your grievances to the Management through Principal / Director only.
- 23) You will have to carry out the duties / work assigned to you by the Principal / Director and the Management besides your teaching work / routine work.
- 24) If you found absent continuously for more than 15 days without prior written permission from the Principal/Director, your services will stand terminated automatically and no further correspondence will be entertained thereafter.
- 25) Any information given in the application form if found incorrect contradictory at any time after the appointment, your services will be terminated forthwith, and no further correspondence will be entertained thereafter.
- 26) Progress Report: You will submit your academic progress report and other activities, seminars, presentation of papers, workshop, Self Appraisal etc. twice every year in the months of April and November.
- 27) If it is observed that your performance is not satisfactory / your behavior is not in the interest of the institute or College or trust / you commit breach of terms and conditions as mentioned in your appointment / you are found medically unfit (physically/mentally), your services shall be terminated without giving any notice period.
- 28) You will have to communicate your acceptance in writing to the Management/Director/Principal **within two weeks** from the date of receipt of Order of Appointment, failing which your appointment is liable to be withdrawal / cancelled. However, in case you need an extension of time limit for joining the duties you will have to apply in writing for grant of extension stating the reasons for the same and indicating the date on which you intend to join the duties. The request for grant of extension of time limit for joining the duties for the post shall be considered and you will be informed in the matter. The decision of the management of the **Dr. D Y Patil School of Engineering** shall be final.
- 29) If you are found guilty of violation of any terms & conditions mentioned above you will be liable for disciplinary action and punishment decided by the Management/Director/ Principal as provided in the Rules & Regulations.
- 30) In view of this appointment order, the previous appointment order/s stands cancelled.
- 31) Any dispute arises in the service will be dealt legally in jurisdiction of Pune City only.

*For Dr. D Y Patil Educational Enterprises Charitable Trust*

*Hrridaysh*

**Hrridaysh Deshpande**  
**Authorized Signatory**



**Copy to:**

- 1 Master File DYPEECT.
- 2 Principal, Dr. D Y Patil School of Engineering  
(Two Copies: [1] Personal File [2] Accounts Section).
- 3 Chief Financial Officer, DYPEECT.



## Dr D Y PATIL EDUCATIONAL ENTERPRISES CHARITABLE TRUST

Ref.ADYPKC/SOE/AO/T/ABT/2020-21/52

Date:01.03.2021

To,  
**Mr. Ahinsak B Taksande**  
At Post Awarpur, Tah Korpana,  
Dist. Chanrdapur. 442917  
Email- abtaksande10@gmail.com  
Contact-9823923699

### Appointment Order

**Mr. Ahinsak B Taksande**

Following your application and subsequent interview for the post of **Assistant Professor**, I am pleased to inform you that the Management has appointed you as **Assistant Professor** in **Department of Civil Engineering** at **Dr. D Y Patil School of Engineering**. The terms & conditions of the appointment are as follows.

- 1) Your services are governed by the Maharashtra Universities Act, statues, ordinances, rules & regulations, code of conduct, laid down by the Savitribai Phule Pune University, Government of Maharashtra and service rules of the Trust and will be responsible to the Principal/Director of the Institute for discharge of your duties.
- 2) Your appointment is on **purely temporary basis** for a period of **Academic Year 2020-21 (i.e. upto 31<sup>st</sup> May 2021 only)** from the date of joining i.e.01<sup>st</sup> March 2021.
- 3) You will be paid consolidated monthly salary of **Rs. 35,000 only (Rs Thirty five Thousand Only)**. No other allowances will be admissible. The salary payment will be subject to statutory deduction of taxes as applicable.
- 4) Your appointment is subject to the minimum numbers of the students and the sufficient workload prescribed for the post.
- 5) Your appointment is on purely temporary basis and will automatically come to an end on the expiry of tenure and in any such event; you shall not claim any right to be continued in the services. You shall not claim to be a regular/permanent employee of the Institute/College. At any time during the tenure of your services or after termination thereof, in any manner whatsoever, and shall not claim automatic re-appointment to the said post after expiry of the tenure of your services and you will not be eligible for any retiral benefits.
- 6) You shall submit the certified true copies of relevant documents such as birth certificate, mark sheets, experience certificates, Approval Letters, reliving certificate, Aadhar Card, PAN card, Last Pay Slip from the previous Employer before joining the duties.
- 7) You will produce 2 passport size recent photographs.
- 8) You are required to give the correct mailing address as soon as you join your duties. It will be presumed that any letter sent by Registered Post Acknowledgement Due (RPAD) or Speed Post or E-Mail on the address given, shall be deemed to have been acknowledged duly signed by you.
- 9) You are entitled Casual Leave as per Rules & Regulation of DYPEECT, subject to changes from time to time.
- 10) You are entitled for Medical Leave only after completion of one-year regular services and as per Rules & Regulation of DYPEECT, subject to changes from time to time.
- 11) If you want to leave the service during the tenure of your appointment, you will have to give one month's notice in writing to the Management. A sum equal to your one months' salary will be deducted or you will need to deposit the same amount to employer in case you resign without serving a one months' notice period. It is desirable that being a teaching faculty, you do not leave the job when the academic session is in progress.
- 12) You will submit to the office the medical fitness certificate from the Registered Medical panel appointed by the DYPEECT before joining your duties.
- 13) You will not conduct or engage yourself in private tuitions or private coaching classes.



Page 1 of 2

- 14) You will not engage yourself in any other paid job, full time, part time, honorary or otherwise during the continuance of your service in this Institute/College. You will not undertake any R & D or consultancy work and not register for any degree / diploma / certificate course without approval of the competent authority of the Trust.
- 15) You will not appear for any examinations/Admission without prior permission of the management in service.
- 16) You will not take any active part in the politics, neither involved directly or indirectly in illegal financial matters.
- 17) Your services are transferable within the trust organization only.
- 18) You will not directly or indirectly get yourself involved in any of the anti-activities against the management which may cause any harm to the institute/college or the management.
- 19) Your behavior with colleagues and entire institute/college staff should be polite, co-operative and gentle.
- 20) You will not form any union or organization amongst yourself and colleagues.
- 21) You will not process any letters either signed by you or signed jointly on any issues against the Management/Authorities without prior permission of the Principal/Director. Also, you will not approach to any authorities connected to the Institute/ College / Trust without prior permission of the Principal / Director.
- 22) You will put your grievances to the Management through Principal / Director only.
- 23) You will have to carry out the duties / work assigned to you by the Principal / Director and the Management besides your teaching work / routine work.
- 24) If you found absent continuously for more than 15 days without prior written permission from the Principal/Director, your services will stand terminated automatically and no further correspondence will be entertained thereafter.
- 25) Any information given in the application form if found incorrect contradictory at any time after the appointment, your services will be terminated forthwith, and no further correspondence will be entertained thereafter.
- 26) Progress Report: You will submit your academic progress report and other activities, seminars, presentation of papers, workshop, Self Appraisal etc. twice every year in the months of April and November.
- 27) If it is observed that your performance is not satisfactory / your behavior is not in the interest of the Institute or College or trust / you commit breach of terms and conditions as mentioned in your appointment / you are found medically unfit (physically/mentally), your services shall be terminated without giving any notice period.
- 28) You will have to communicate your acceptance in writing to the Management/Director/Principal **within two weeks** from the date of receipt of Order of Appointment, failing which your appointment is liable to be withdrawal / cancelled. However, in case you need an extension of time limit for joining the duties you will have to apply in writing for grant of extension stating the reasons for the same and indicating the date on which you intend to join the duties. The request for grant of extension of time limit for joining the duties for the post shall be considered and you will be informed in the matter. The decision of the management of the **Dr. D Y Patil School of Engineering** shall be final.
- 29) If you are found guilty of violation of any terms & conditions mentioned above you will be liable for disciplinary action and punishment decided by the Management/Director/ Principal as provided in the Rules & Regulations.
- 30) In view of this appointment order, the previous appointment order/s stands cancelled.
- 31) Any dispute arises in the service will be dealt legally in jurisdiction of Pune City only.

For Dr. D Y Patil Educational Enterprises Charitable Trust

*Hridaysh*  
**Hridaysh Deshpande**  
 Authorized Signatory



Copy to:

- 1 Master File DYPEECT.
- 2 Principal, Dr. D Y Patil School of Engineering  
(Two Copies: [1] Personal File [2] Accounts Section).
- 3 Chief Financial Officer, DYPEECT.

*Received*  
*Chiranjiv*  
 19/03/21



**Dr D Y PATIL EDUCATIONAL ENTERPRISES CHARITABLE TRUST**

Ref.ADYPKC/SOE/AO/T/JDD/2020-21/ 51

Date: 01.03.2021

To,  
**Mr. Jitendra Dattatray Dalvi**  
Flat No B203, Shivdeep Arcade,  
Azad Chowk Near Grampachayant  
Lohegaon-411047  
Email- jitendradalvi933@gmail.com  
Contact-9923399133

**Appointment Order**

**Mr. Jitendra Dattatray Dalvi,**

Following your application and subsequent interview for the post of **Assistant Professor**, I am pleased to inform you that the Management has appointed you as **Assistant Professor** in **Department of Civil Engineering** at **Dr. D Y Patil School of Engineering**. The terms & conditions of the appointment are as follows.

- 1) Your services are governed by the Maharashtra Universities Act, statues, ordinances, rules & regulations, code of conduct, laid down by the Savitribai Phule Pune University, Government of Maharashtra and service rules of the Trust and will be responsible to the Principal/Director of the Institute for discharge of your duties.
- 2) Your appointment is on **purely temporary basis** for a period of **Academic Year 2020-21 (i.e. upto 31<sup>st</sup> May 2021 only)** from the date of joining i.e.01<sup>st</sup> March 2021.
- 3) You will be paid consolidated monthly salary of **Rs. 35,000 only (Rs Thirty five Thousand Only)**. No other allowances will be admissible. The salary payment will be subject to statutory deduction of taxes as applicable.
- 4) Your appointment is subject to the minimum numbers of the students and the sufficient workload prescribed for the post.
- 5) Your appointment is on purely temporary basis and will automatically come to an end on the expiry of tenure and in any such event; you shall not claim any right to be continued in the services. You shall not claim to be a regular/permanent employee of the Institute/College. At any time during the tenure of your services or after termination thereof, in any manner whatsoever, and shall not claim automatic re-appointment to the said post after expiry of the tenure of your services and you will not be eligible for any retiral benefits.
- 6) You shall submit the certified true copies of relevant documents such as birth certificate, mark sheets, experience certificates, Approval Letters, reliving certificate, Aadhar Card, PAN card, Last Pay Slip from the previous Employer before joining the duties.
- 7) You will produce 2 passport size recent photographs.
- 8) You are required to give the correct mailing address as soon as you join your duties. It will be presumed that any letter sent by Registered Post Acknowledgement Due (RPAD) or Speed Post or E-Mail on the address given, shall be deemed to have been acknowledged duly signed by you.
- 9) You are entitled Casual Leave as per Rules & Regulation of DYPEECT, subject to changes from time to time.
- 10) You are entitled for Medical Leave only after completion of one-year regular services and as per Rules & Regulation of DYPEECT, subject to changes from time to time.
- 11) If you want to leave the service during the tenure of your appointment, you will have to give one month's notice in writing to the Management. A sum equal to your one months' salary will be deducted or you will need to deposit the same amount to employer in case you resign without serving a one months' notice period. It is desirable that being a teaching faculty, you do not leave the job when the academic session is in progress.
- 12) You will submit to the office the medical fitness certificate from the Registered Medical panel appointed by the DYPEECT before joining your duties.
- 13) You will not conduct or engage yourself in private tuitions or private coaching classes.

*Received -*  
*[Signature]*

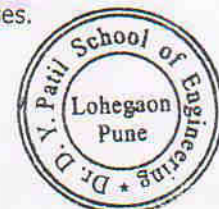

- 14) You will not engage yourself in any other paid job, full time, part time, honorary or otherwise during the continuance of your service in this Institute/College. You will not undertake any R & D or consultancy work and not register for any degree / diploma / certificate course without approval of the competent authority of the Trust.
- 15) You will not appear for any examinations/Admission without prior permission of the management in service.
- 16) You will not take any active part in the politics, neither involved directly or indirectly in illegal financial matters.
- 17) Your services are transferable within the trust organization only.
- 18) You will not directly or indirectly get yourself involved in any of the anti-activities against the management which may cause any harm to the institute/college or the management.
- 19) Your behavior with colleagues and entire institute/college staff should be polite, co-operative and gentle.
- 20) You will not form any union or organization amongst yourself and colleagues.
- 21) You will not process any letters either signed by you or signed jointly on any issues against the Management/Authorities without prior permission of the Principal/Director. Also, you will not approach to any authorities connected to the Institute/ College / Trust without prior permission of the Principal / Director.
- 22) You will put your grievances to the Management through Principal / Director only.
- 23) You will have to carry out the duties / work assigned to you by the Principal / Director and the Management besides your teaching work / routine work.
- 24) If you found absent continuously for more than 15 days without prior written permission from the Principal/Director, your services will stand terminated automatically and no further correspondence will be entertained thereafter.
- 25) Any information given in the application form if found incorrect contradictory at any time after the appointment, your services will be terminated forthwith, and no further correspondence will be entertained thereafter.
- 26) Progress Report: You will submit your academic progress report and other activities, seminars, presentation of papers, workshop, Self Appraisal etc. twice every year in the months of April and November.
- 27) If it is observed that your performance is not satisfactory / your behavior is not in the interest of the institute or College or trust / you commit breach of terms and conditions as mentioned in your appointment / you are found medically unfit (physically/mentally), your services shall be terminated without giving any notice period.
- 28) You will have to communicate your acceptance in writing to the Management/Director/Principal **within two weeks** from the date of receipt of Order of Appointment, failing which your appointment is liable to be withdrawal / cancelled. However, in case you need an extension of time limit for joining the duties you will have to apply in writing for grant of extension stating the reasons for the same and indicating the date on which you intend to join the duties. The request for grant of extension of time limit for joining the duties for the post shall be considered and you will be informed in the matter. The decision of the management of the **Dr. D Y Patil School of Engineering** shall be final.
- 29) If you are found guilty of violation of any terms & conditions mentioned above you will be liable for disciplinary action and punishment decided by the Management/Director/ Principal as provided in the Rules & Regulations.
- 30) In view of this appointment order, the previous appointment order/s stands cancelled.
- 31) Any dispute arises in the service will be dealt legally in jurisdiction of Pune City only.

For Dr. D Y Patil Educational Enterprises Charitable Trust

*Hridaysh*  
**Hridaysh Deshpande**  
 Authorized Signatory



**Copy to:**

- 1 Master File DYPEECT.
- 2 Principal, Dr. D Y Patil School of Engineering  
(Two Copies: [1] Personal File [2] Accounts Section).
- 3 Chief Financial Officer, DYPEECT.



D Y PATIL GROUP

Dr D Y PATIL EDUCATIONAL ENTERPRISES CHARITABLE TRUST

Ref.ADYPKC/SOE/AO/T/SB/2020-21/ 05

Date: 10.08.2020

To,  
Mr. Swapnil Bijwe  
Aurum Elementto,  
F-704, Porwal Road,  
Lohegaon,  
Pune  
Email- swapnil\_bijwe@rediffmail.com  
Contact- 9096551264

Appointment Order

Mr. Swapnil Bijwe,

Following your application and subsequent interview for the post of **Assistant Professor**, I am pleased to inform you that the Management has appointed you as **Assistant Professor in Civil Engineering Department at Dr. D Y Patil School of Engineering**. The terms & conditions of the appointment are as follows.

- 1) Your services are governed by the Maharashtra Universities Act, statues, ordinances, rules & regulations, code of conduct, laid down by the Savitribai Phule Pune University, Government of Maharashtra and service rules of the Trust and will be responsible to the Principal/Director of the Institute for discharge of your duties.
- 2) Your appointment is on **purely temporary basis** for a period of **Academic Year 2020-21 (i.e. upto 31<sup>st</sup> May 2021 only)** from the date of joining i.e.10<sup>th</sup> August 2020.
- 3) You will be paid consolidated monthly salary of **Rs. 35,000 only (Rs Thirty five Thousand Only)**. No other allowances will be admissible. The salary payment will be subject to statutory deduction of taxes as applicable.
- 4) Your appointment is subject to the minimum numbers of the students and the sufficient workload prescribed for the post.
- 5) Your appointment is on purely temporary basis and will automatically come to an end on the expiry of tenure and in any such event; you shall not claim any right to be continued in the services. You shall not claim to be a regular/permanent employee of the Institute/College. At any time during the tenure of your services or after termination thereof, in any manner whatsoever, and shall not claim automatic re-appointment to the said post after expiry of the tenure of your services and you will not be eligible for any retiral benefits.
- 6) You shall submit the certified true copies of relevant documents such as birth certificate, mark sheets, experience certificates, Approval Letters, reliving certificate, Aadhar Card, PAN card, Last Pay Slip from the previous Employer before joining the duties.
- 7) You will produce 2 passport size recent photographs.
- 8) You are required to give the correct mailing address as soon as you join your duties. It will be presumed that any letter sent by Registered Post Acknowledgement Due (RPAD) or Speed Post or E-Mail on the address given, shall be deemed to have been acknowledged duly signed by you.
- 9) You are entitled Casual Leave as per Rules & Regulation of DYPEECT, subject to changes from time to time.
- 10) You are entitled for Medical Leave only after completion of one-year regular services and as per Rules & Regulation of DYPEECT, subject to changes from time to time.
- 11) If you want to leave the service during the tenure of your appointment, you will have to give one month's notice in writing to the Management. A sum equal to your one months' salary will be deducted or you will need to deposit the same amount to employer in case you resign without serving a one months' notice period. It is desirable that being a teaching faculty, you do not leave the job when the academic session is in progress.
- 12) You will submit to the office the medical fitness certificate from the Registered Medical panel appointed by the DYPEECT before joining your duties.

Page 1 of 2

Received  
25/08/20



- 13) You will not conduct or engage yourself in private tuitions or private coaching classes.
- 14) You will not engage yourself in any other paid job, full time, part time, honorary or otherwise during the continuance of your service in this Institute/College. You will not undertake any R & D or consultancy work and not register for any degree / diploma / certificate course without approval of the competent authority of the Trust.
- 15) You will not appear for any examinations/Admission without prior permission of the management in service.
- 16) You will not take any active part in the politics, neither involved directly or indirectly in illegal financial matters.
- 17) Your services are transferable within the trust organization only.
- 18) You will not directly or indirectly get yourself involved in any of the anti-activities against the management which may cause any harm to the institute/college or the management.
- 19) Your behavior with colleagues and entire institute/college staff should be polite, co-operative and gentle.
- 20) You will not form any union or organization amongst yourself and colleagues.
- 21) You will not process any letters either signed by you or signed jointly on any issues against the Management/Authorities without prior permission of the Principal/Director. Also, you will not approach to any authorities connected to the Institute/ College / Trust without prior permission of the Principal / Director.
- 22) You will put your grievances to the Management through Principal / Director only.
- 23) You will have to carry out the duties / work assigned to you by the Principal / Director and the Management besides your teaching work / routine work.
- 24) If you found absent continuously for more than 15 days without prior written permission from the Principal/Director, your services will stand terminated automatically and no further correspondence will be entertained thereafter.
- 25) Any information given in the application form if found incorrect contradictory at any time after the appointment, your services will be terminated forthwith, and no further correspondence will be entertained thereafter.
- 26) Progress Report: You will submit your academic progress report and other activities, seminars, presentation of papers, workshop, Self Appraisal etc. twice every year in the months of April and November.
- 27) If it is observed that your performance is not satisfactory / your behavior is not in the interest of the institute or College or trust / you commit breach of terms and conditions as mentioned in your appointment / you are found medically unfit (physically/mentally), your services shall be terminated without giving any notice period.
- 28) You will have to communicate your acceptance in writing to the Management/Director/Principal **within two weeks** from the date of receipt of Order of Appointment, failing which your appointment is liable to be withdrawal / cancelled. However, in case you need an extension of time limit for joining the duties you will have to apply in writing for grant of extension stating the reasons for the same and indicating the date on which you intend to join the duties. The request for grant of extension of time limit for joining the duties for the post shall be considered and you will be informed in the matter. The decision of the management of the **Dr. D Y Patil School of Engineering** shall be final.
- 29) If you are found guilty of violation of any terms & conditions mentioned above you will be liable for disciplinary action and punishment decided by the Management/Director/ Principal as provided in the Rules & Regulations.
- 30) In view of this appointment order, the previous appointment order/s stands cancelled.
- 31) Any dispute arises in the service will be dealt legally in jurisdiction of Pune City only.

*For Dr. D Y Patil Educational Enterprises Charitable Trust*

*Hridaysh*  
**Hridaysh Deshpande**  
**Authorized Signatory**



**Copy to:**

- 1 Master File DYPEECT.
- 2 Principal, Dr. D Y Patil School of Engineering  
(Two Copies: [1] Personal File [2] Accounts Section).
- 3 Chief Financial Officer, DYPEECT.



D Y PATIL GROUP

**Dr D Y PATIL EDUCATIONAL ENTERPRISES CHARITABLE TRUST**

Ref. ADYPKC/SOE/AO/T/UK/2020-21/06

Date: 17.08.2020

To,  
Mr. Uday A. Kakde  
Tirupati Kashi Ganga,  
Apt, B1-303,  
Dhanori, Pune 15  
Email- udaykakde28@gmail.com  
Contact- 9096288102

**Appointment Order**

**Mr. Uday A. Kakde,**

Following your application and subsequent interview for the post of **Assistant Professor**, I am pleased to inform you that the Management has appointed you as **Assistant Professor** in **Civil Engineering Department** at **Dr. D Y Patil School of Engineering**. The terms & conditions of the appointment are as follows.

- 1) Your services are governed by the Maharashtra Universities Act, statues, ordinances, rules & regulations, code of conduct, laid down by the Savitribai Phule Pune University, Government of Maharashtra and service rules of the Trust and will be responsible to the Principal/Director of the Institute for discharge of your duties.
- 2) Your appointment is on **purely temporary basis** for a period of **Academic Year 2020-21 (i.e. upto 31<sup>st</sup> May 2021 only)** from the date of joining i.e. 17<sup>th</sup> August 2020.
- 3) You will be paid consolidated monthly salary of **Rs. 35,000 Only (Rs Thirty five Thousand Only)**. No other allowances will be admissible. The salary payment will be subject to statutory deduction of taxes as applicable.
- 4) Your appointment is subject to the minimum numbers of the students and the sufficient workload prescribed for the post.
- 5) Your appointment is on purely temporary basis and will automatically come to an end on the expiry of tenure and in any such event; you shall not claim any right to be continued in the services. You shall not claim to be a regular/permanent employee of the Institute/College. At any time during the tenure of your services or after termination thereof, in any manner whatsoever, and shall not claim automatic re-appointment to the said post after expiry of the tenure of your services and you will not be eligible for any retiral benefits.
- 6) You shall submit the certified true copies of relevant documents such as birth certificate, mark sheets, experience certificates, Approval Letters, reliving certificate, Aadhar Card, PAN card, Last Pay Slip from the previous Employer before joining the duties.
- 7) You will produce 2 passport size recent photographs.
- 8) You are required to give the correct mailing address as soon as you join your duties. It will be presumed that any letter sent by Registered Post Acknowledgement Due (RPAD) or Speed Post or E-Mail on the address given, shall be deemed to have been acknowledged duly signed by you.
- 9) You are entitled Casual Leave as per Rules & Regulation of DYPEECT, subject to changes from time to time.
- 10) You are entitled for Medical Leave only after completion of one-year regular services and as per Rules & Regulation of DYPEECT, subject to changes from time to time.
- 11) If you want to leave the service during the tenure of your appointment, you will have to give one month's notice in writing to the Management. A sum equal to your one months' salary will be deducted or you will need to deposit the same amount to employer in case you resign without serving a one months' notice period. It is desirable that being a teaching faculty, you do not leave the job when the academic session is in progress.
- 12) You will submit to the office the medical fitness certificate from the Registered Medical panel appointed by the DYPEECT before joining your duties.

Page 1 of 2

Received  
Uday Kakde  
25/08/20





**Dr D Y PATIL EDUCATIONAL ENTERPRISES CHARITABLE TRUST**

Ref.ADYPKC/SOE/AO/T/AI/2020-21/ 07

Date: 10.08.2020

To,  
Ms. Aakanksha Arun Ingle  
Flat No.708, D wing,  
Aura County society,  
Behind mapple Hotel,  
Ubale nagar, wagholi,  
Pune.  
Email- [aakankshaingle16@gmail.com](mailto:aakankshaingle16@gmail.com)  
Contact- 8888810569

**Appointment Order**

**Ms. Aakanksha Arun Ingle,**

Following your application and subsequent interview for the post of **Assistant Professor**, I am pleased to inform you that the Management has appointed you as **Assistant Professor in Civil Engineering Department at Dr. D Y Patil School of Engineering**. The terms & conditions of the appointment are as follows.

- 1) Your services are governed by the Maharashtra Universities Act, statues, ordinances, rules & regulations, code of conduct, laid down by the Savitribai Phule Pune University, Government of Maharashtra and service rules of the Trust and will be responsible to the Principal/Director of the Institute for discharge of your duties.
- 2) Your appointment is on **purely temporary basis** for a period of **Academic Year 2020-21 (i.e. upto 31<sup>st</sup> May 2021 only)** from the date of joining i.e.10<sup>th</sup> August 2020.
- 3) You will be paid consolidated monthly salary of **Rs. 35,000 Only (Rs Thirty five Thousand Only)**. No other allowances will be admissible. The salary payment will be subject to statutory deduction of taxes as applicable.
- 4) Your appointment is subject to the minimum numbers of the students and the sufficient workload prescribed for the post.
- 5) Your appointment is on purely temporary basis and will automatically come to an end on the expiry of tenure and in any such event; you shall not claim any right to be continued in the services. You shall not claim to be a regular/permanent employee of the Institute/College. At any time during the tenure of your services or after termination thereof, in any manner whatsoever, and shall not claim automatic re-appointment to the said post after expiry of the tenure of your services and you will not be eligible for any retiral benefits.
- 6) You shall submit the certified true copies of relevant documents such as birth certificate, mark sheets, experience certificates, Approval Letters, reliving certificate, Aadhar Card, PAN card, Last Pay Slip from the previous Employer before joining the duties.
- 7) You will produce 2 passport size recent photographs.
- 8) You are required to give the correct mailing address as soon as you join your duties. It will be presumed that any letter sent by Registered Post Acknowledgement Due (RPAD) or Speed Post or E-Mail on the address given, shall be deemed to have been acknowledged duly signed by you.
- 9) You are entitled Casual Leave as per Rules & Regulation of DYPEECT, subject to changes from time to time.
- 10) You are entitled for Medical Leave only after completion of one-year regular services and as per Rules & Regulation of DYPEECT, subject to changes from time to time.
- 11) If you want to leave the service during the tenure of your appointment, you will have to give one month's notice in writing to the Management. A sum equal to your one months' salary will be deducted or you will need to deposit the same amount to employer in case you resign without serving a one months' notice period. It is desirable that being a teaching faculty, you do not leave the job when the academic session is in progress.
- 12) You will submit to the office the medical fitness certificate from the Registered Medical panel appointed by the DYPEECT before joining your duties.

Page 1 of 2

*A. Y. Patil*  
21/8/20

- 13) You will not conduct or engage yourself in private tuitions or private coaching classes.
- 14) You will not engage yourself in any other paid job, full time, part time, honorary or otherwise during the continuance of your service in this Institute/College. You will not undertake any R & D or consultancy work and not register for any degree / diploma / certificate course without approval of the competent authority of the Trust.
- 15) You will not appear for any examinations/Admission without prior permission of the management in service.
- 16) You will not take any active part in the politics, neither involved directly or indirectly in illegal financial matters.
- 17) Your services are transferable within the trust organization only.
- 18) You will not directly or indirectly get yourself involved in any of the anti-activities against the management which may cause any harm to the institute/college or the management.
- 19) Your behavior with colleagues and entire institute/college staff should be polite, co-operative and gentle.
- 20) You will not form any union or organization amongst yourself and colleagues.
- 21) You will not process any letters either signed by you or signed jointly on any issues against the Management/Authorities without prior permission of the Principal/Director. Also, you will not approach to any authorities connected to the Institute/ College / Trust without prior permission of the Principal / Director.
- 22) You will put your grievances to the Management through Principal / Director only.
- 23) You will have to carry out the duties / work assigned to you by the Principal / Director and the Management besides your teaching work / routine work.
- 24) If you found absent continuously for more than 15 days without prior written permission from the Principal/Director, your services will stand terminated automatically and no further correspondence will be entertained thereafter.
- 25) Any information given in the application form if found incorrect contradictory at any time after the appointment, your services will be terminated forthwith, and no further correspondence will be entertained thereafter.
- 26) Progress Report: You will submit your academic progress report and other activities, seminars, presentation of papers, workshop, Self Appraisal etc. twice every year in the months of April and November.
- 27) If it is observed that your performance is not satisfactory / your behavior is not in the interest of the institute or College or trust / you commit breach of terms and conditions as mentioned in your appointment / you are found medically unfit (physically/mentally), your services shall be terminated without giving any notice period.
- 28) You will have to communicate your acceptance in writing to the Management/Director/Principal **within two weeks** from the date of receipt of Order of Appointment, failing which your appointment is liable to be withdrawal / cancelled. However, in case you need an extension of time limit for joining the duties you will have to apply in writing for grant of extension stating the reasons for the same and indicating the date on which you intend to join the duties. The request for grant of extension of time limit for joining the duties for the post shall be considered and you will be informed in the matter. The decision of the management of the **Dr. D Y Patil School of Engineering** shall be final.
- 29) If you are found guilty of violation of any terms & conditions mentioned above you will be liable for disciplinary action and punishment decided by the Management/Director/ Principal as provided in the Rules & Regulations.
- 30) In view of this appointment order, the previous appointment order/s stands cancelled.
- 31) Any dispute arises in the service will be dealt legally in jurisdiction of Pune City only.

*For Dr. D Y Patil Educational Enterprises Charitable Trust*

*Hridaysh*  
**Hridaysh Deshpande**  
**Authorized Signatory**



**Copy to:**

- 1 Master File DYPECT.
- 2 Principal, Dr. D Y Patil School of Engineering  
(Two Copies: [1] Personal File [2] Accounts Section).
- 3 Chief Financial Officer, DYPECT.



## Dr D Y PATIL EDUCATIONAL ENTERPRISES CHARITABLE TRUST

Ref.ADYPKC/SOE/AO/T/AG/2020-21/08

Date: 14.08.2020

To,  
Ms. Aradhna Ganvir  
A/204 Splendid Square  
Lohegaon, Dhanori Road,  
Pune-  
Email- aradhnaganvir@dypic.in  
Contact- 7219553980

### Appointment Order

**Ms. Aradhna Ganvir,**

Following your application and subsequent interview for the post of **Assistant Professor**, I am pleased to inform you that the Management has appointed you as **Assistant Professor in Civil Engineering Department at Dr. D Y Patil School of Engineering**. The terms & conditions of the appointment are as follows.

- 1) Your services are governed by the Maharashtra Universities Act, statues, ordinances, rules & regulations, code of conduct, laid down by the Savitribai Phule Pune University, Government of Maharashtra and service rules of the Trust and will be responsible to the Principal/Director of the Institute for discharge of your duties.
- 2) Your appointment is on **purely temporary basis** for a period of **Academic Year 2020-21 (i.e. upto 31<sup>st</sup> May 2021 only)** from the date of joining i.e.14<sup>th</sup> August 2020.
- 3) You will be paid consolidated monthly salary of **Rs. 35,000 Only (Rs Thirty five Thousand Only)**. No other allowances will be admissible. The salary payment will be subject to statutory deduction of taxes as applicable.
- 4) Your appointment is subject to the minimum numbers of the students and the sufficient workload prescribed for the post.
- 5) Your appointment is on purely temporary basis and will automatically come to an end on the expiry of tenure and in any such event; you shall not claim any right to be continued in the services. You shall not claim to be a regular/permanent employee of the Institute/College. At any time during the tenure of your services or after termination thereof, in any manner whatsoever, and shall not claim automatic re-appointment to the said post after expiry of the tenure of your services and you will not be eligible for any retiral benefits.
- 6) You shall submit the certified true copies of relevant documents such as birth certificate, mark sheets, experience certificates, Approval Letters, reliving certificate, Aadhar Card, PAN card, Last Pay Slip from the previous Employer before joining the duties.
- 7) You will produce 2 passport size recent photographs.
- 8) You are required to give the correct mailing address as soon as you join your duties. It will be presumed that any letter sent by Registered Post Acknowledgement Due (RPAD) or Speed Post or E-Mail on the address given, shall be deemed to have been acknowledged duly signed by you.
- 9) You are entitled Casual Leave as per Rules & Regulation of DYPEECT, subject to changes from time to time.
- 10) You are entitled for Medical Leave only after completion of one-year regular services and as per Rules & Regulation of DYPEECT, subject to changes from time to time.
- 11) If you want to leave the service during the tenure of your appointment, you will have to give one month's notice in writing to the Management. A sum equal to your one months' salary will be deducted or you will need to deposit the same amount to employer in case you resign without serving a one months' notice period. It is desirable that being a teaching faculty, you do not leave the job when the academic session is in progress.
- 12) You will submit to the office the medical fitness certificate from the Registered Medical panel appointed by the DYPEECT before joining your duties.

Page 1 of 2

*Aradhna*  
31/Aug/2020

- 13) You will not conduct or engage yourself in private tuitions or private coaching classes.
- 14) You will not engage yourself in any other paid job, full time, part time, honorary or otherwise during the continuance of your service in this Institute/College. You will not undertake any R & D or consultancy work and not register for any degree / diploma / certificate course without approval of the competent authority of the Trust.
- 15) You will not appear for any examinations/Admission without prior permission of the management in service.
- 16) You will not take any active part in the politics, neither involved directly or indirectly in illegal financial matters.
- 17) Your services are transferable within the trust organization only.
- 18) You will not directly or indirectly get yourself involved in any of the anti-activities against the management which may cause any harm to the institute/college or the management.
- 19) Your behavior with colleagues and entire institute/college staff should be polite, co-operative and gentle.
- 20) You will not form any union or organization amongst yourself and colleagues.
- 21) You will not process any letters either signed by you or signed jointly on any issues against the Management/Authorities without prior permission of the Principal/Director. Also, you will not approach to any authorities connected to the Institute/ College / Trust without prior permission of the Principal / Director.
- 22) You will put your grievances to the Management through Principal / Director only.
- 23) You will have to carry out the duties / work assigned to you by the Principal / Director and the Management besides your teaching work / routine work.
- 24) If you found absent continuously for more than 15 days without prior written permission from the Principal/Director, your services will stand terminated automatically and no further correspondence will be entertained thereafter.
- 25) Any information given in the application form if found incorrect contradictory at any time after the appointment, your services will be terminated forthwith, and no further correspondence will be entertained thereafter.
- 26) Progress Report: You will submit your academic progress report and other activities, seminars, presentation of papers, workshop, Self Appraisal etc. twice every year in the months of April and November.
- 27) If it is observed that your performance is not satisfactory / your behavior is not in the interest of the institute or College or trust / you commit breach of terms and conditions as mentioned in your appointment / you are found medically unfit (physically/mentally), your services shall be terminated without giving any notice period.
- 28) You will have to communicate your acceptance in writing to the Management/Director/Principal **within two weeks** from the date of receipt of Order of Appointment, failing which your appointment is liable to be withdrawal / cancelled. However, in case you need an extension of time limit for joining the duties you will have to apply in writing for grant of extension stating the reasons for the same and indicating the date on which you intend to join the duties. The request for grant of extension of time limit for joining the duties for the post shall be considered and you will be informed in the matter. The decision of the management of the **Dr. D Y Patil School of Engineering** shall be final.
- 29) If you are found guilty of violation of any terms & conditions mentioned above you will be liable for disciplinary action and punishment decided by the Management/Director/ Principal as provided in the Rules & Regulations.
- 30) In view of this appointment order, the previous appointment order/s stands cancelled.
- 31) Any dispute arises in the service will be dealt legally in jurisdiction of Pune City only.

*For Dr. D Y Patil Educational Enterprises Charitable Trust*

*Hridaysh*  
**Hridaysh Deshpande**  
**Authorized Signatory**



**Copy to:**

- 1 Master File DYPEECT.
- 2 Principal, Dr. D Y Patil School of Engineering  
(Two Copies: [1] Personal File [2] Accounts Section).
- 3 Chief Financial Officer, DYPEECT.



D Y PATIL GROUP

**Dr D Y PATIL EDUCATIONAL ENTERPRISES CHARITABLE TRUST**

Ref.ADYPKC/SOE/AO/T/PS/2020-21/09

Date: 10.08.2020

To,  
Ms. Pragya Sharma  
Flat No.03, Krishna Rang Regency,  
Ganesh Nagar, Bopkhel,  
Pune  
Email- pragyaad84@gmail.com  
Contact- 9783215981

**Appointment Order**

**Ms. Pragya Sharma,**

Following your application and subsequent interview for the post of **Assistant Professor**, I am pleased to inform you that the Management has appointed you as **Assistant Professor in Civil Engineering Department at Dr. D Y Patil School of Engineering**. The terms & conditions of the appointment are as follows.

- 1) Your services are governed by the Maharashtra Universities Act, statues, ordinances, rules & regulations, code of conduct, laid down by the Savitribai Phule Pune University, Government of Maharashtra and service rules of the Trust and will be responsible to the Principal/Director of the Institute for discharge of your duties.
- 2) Your appointment is on **purely temporary basis** for a period of **Academic Year 2020-21 (i.e. upto 31<sup>st</sup> May 2021 only)** from the date of joining i.e.10<sup>th</sup> August 2020.
- 3) You will be paid consolidated monthly salary of **Rs. 35,000 Only (Rs Thirty five Thousand Only)**. No other allowances will be admissible. The salary payment will be subject to statutory deduction of taxes as applicable.
- 4) Your appointment is subject to the minimum numbers of the students and the sufficient workload prescribed for the post.
- 5) Your appointment is on purely temporary basis and will automatically come to an end on the expiry of tenure and in any such event; you shall not claim any right to be continued in the services. You shall not claim to be a regular/permanent employee of the Institute/College. At any time during the tenure of your services or after termination thereof, in any manner whatsoever, and shall not claim automatic re-appointment to the said post after expiry of the tenure of your services and you will not be eligible for any retiral benefits.
- 6) You shall submit the certified true copies of relevant documents such as birth certificate, mark sheets, experience certificates, Approval Letters, reliving certificate, Aadhar Card, PAN card, Last Pay Slip from the previous Employer before joining the duties.
- 7) You will produce 2 passport size recent photographs.
- 8) You are required to give the correct mailing address as soon as you join your duties. It will be presumed that any letter sent by Registered Post Acknowledgement Due (RPAD) or Speed Post or E-Mail on the address given, shall be deemed to have been acknowledged duly signed by you.
- 9) You are entitled Casual Leave as per Rules & Regulation of DYPEECT, subject to changes from time to time.
- 10) You are entitled for Medical Leave only after completion of one-year regular services and as per Rules & Regulation of DYPEECT, subject to changes from time to time.
- 11) If you want to leave the service during the tenure of your appointment, you will have to give one month's notice in writing to the Management. A sum equal to your one months' salary will be deducted or you will need to deposit the same amount to employer in case you resign without serving a one months' notice period. It is desirable that being a teaching faculty, you do not leave the job when the academic session is in progress.
- 12) You will submit to the office the medical fitness certificate from the Registered Medical panel appointed by the DYPEECT before joining your duties.

Received  
Pragya Sharma  
26/08/20

Page 1 of 2



- 13) You will not conduct or engage yourself in private tuitions or private coaching classes.
- 14) You will not engage yourself in any other paid job, full time, part time, honorary or otherwise during the continuance of your service in this Institute/College. You will not undertake any R & D or consultancy work and not register for any degree / diploma / certificate course without approval of the competent authority of the Trust.
- 15) You will not appear for any examinations/Admission without prior permission of the management in service.
- 16) You will not take any active part in the politics, neither involved directly or indirectly in illegal financial matters.
- 17) Your services are transferable within the trust organization only.
- 18) You will not directly or indirectly get yourself involved in any of the anti-activities against the management which may cause any harm to the institute/college or the management.
- 19) Your behavior with colleagues and entire institute/college staff should be polite, co-operative and gentle.
- 20) You will not form any union or organization amongst yourself and colleagues.
- 21) You will not process any letters either signed by you or signed jointly on any issues against the Management/Authorities without prior permission of the Principal/Director. Also, you will not approach to any authorities connected to the Institute/ College / Trust without prior permission of the Principal / Director.
- 22) You will put your grievances to the Management through Principal / Director only.
- 23) You will have to carry out the duties / work assigned to you by the Principal / Director and the Management besides your teaching work / routine work.
- 24) If you found absent continuously for more than 15 days without prior written permission from the Principal/Director, your services will stand terminated automatically and no further correspondence will be entertained thereafter.
- 25) Any information given in the application form if found incorrect contradictory at any time after the appointment, your services will be terminated forthwith, and no further correspondence will be entertained thereafter.
- 26) Progress Report: You will submit your academic progress report and other activities, seminars, presentation of papers, workshop, Self Appraisal etc. twice every year in the months of April and November.
- 27) If it is observed that your performance is not satisfactory / your behavior is not in the interest of the institute or College or trust / you commit breach of terms and conditions as mentioned in your appointment / you are found medically unfit (physically/mentally), your services shall be terminated without giving any notice period.
- 28) You will have to communicate your acceptance in writing to the Management/Director/Principal **within two weeks** from the date of receipt of Order of Appointment, failing which your appointment is liable to be withdrawal / cancelled. However, in case you need an extension of time limit for joining the duties you will have to apply in writing for grant of extension stating the reasons for the same and indicating the date on which you intend to join the duties. The request for grant of extension of time limit for joining the duties for the post shall be considered and you will be informed in the matter. The decision of the management of the **Dr. D Y Patil School of Engineering** shall be final.
- 29) If you are found guilty of violation of any terms & conditions mentioned above you will be liable for disciplinary action and punishment decided by the Management/Director/ Principal as provided in the Rules & Regulations.
- 30) In view of this appointment order, the previous appointment order/s stands cancelled.
- 31) Any dispute arises in the service will be dealt legally in jurisdiction of Pune City only.

*For Dr. D Y Patil Educational Enterprises Charitable Trust*

*Hrridaysh*  
**Hrridaysh Deshpande**  
**Authorized Signatory**



**Copy to:**

- 1 Master File DYPEECT.
- 2 Principal, Dr. D Y Patil School of Engineering  
(Two Copies: [1] Personal File, [2] Accounts Section).
- 3 Chief Financial Officer, DYPEECT.



Dr D Y PATIL GROUP

Dr D Y PATIL EDUCATIONAL ENTERPRISES CHARITABLE TRUST

Ref.ADYPKC/SOE/AO/T/US/2020-21/ (D

Date: 11.08.2020

To,  
Ms. Uzma Shaikh  
Barshi road, Behind bajaj Showroom,  
Near Mehmoodiya Masjid,  
Chandhry Nagar,  
Latur-413531  
Email- 8962uzma@gmail.com  
Contact- 9168133310

Appointment Order

Ms. Uzma Shaikh,

Following your application and subsequent interview for the post of **Assistant Professor**, I am pleased to inform you that the Management has appointed you as **Assistant Professor in Civil Engineering Department at Dr. D Y Patil School of Engineering**. The terms & conditions of the appointment are as follows.

- 1) Your services are governed by the Maharashtra Universities Act, statues, ordinances, rules & regulations, code of conduct, laid down by the Savitribai Phule Pune University, Government of Maharashtra and service rules of the Trust and will be responsible to the Principal/Director of the Institute for discharge of your duties.
- 2) Your appointment is on **purely temporary basis** for a period of **Academic Year 2020-21 (i.e. upto 31<sup>st</sup> May 2021 only)** from the date of joining i.e.11<sup>th</sup> August 2020.
- 3) You will be paid consolidated monthly salary of **Rs. 35,000 Only (Rs Thirty five Thousand Only)**. No other allowances will be admissible. The salary payment will be subject to statutory deduction of taxes as applicable.
- 4) Your appointment is subject to the minimum numbers of the students and the sufficient workload prescribed for the post.
- 5) Your appointment is on purely temporary basis and will automatically come to an end on the expiry of tenure and in any such event; you shall not claim any right to be continued in the services. You shall not claim to be a regular/permanent employee of the Institute/College. At any time during the tenure of your services or after termination thereof, in any manner whatsoever, and shall not claim automatic re-appointment to the said post after expiry of the tenure of your services and you will not be eligible for any retiral benefits.
- 6) You shall submit the certified true copies of relevant documents such as birth certificate, mark sheets, experience certificates, Approval Letters, reliving certificate, Aadhar Card, PAN card, Last Pay Slip from the previous Employer before joining the duties.
- 7) You will produce 2 passport size recent photographs.
- 8) You are required to give the correct mailing address as soon as you join your duties. It will be presumed that any letter sent by Registered Post Acknowledgement Due (RPAD) or Speed Post or E-Mail on the address given, shall be deemed to have been acknowledged duly signed by you.
- 9) You are entitled Casual Leave as per Rules & Regulation of DYPEECT, subject to changes from time to time.
- 10) You are entitled for Medical Leave only after completion of one-year regular services and as per Rules & Regulation of DYPEECT, subject to changes from time to time.
- 11) If you want to leave the service during the tenure of your appointment, you will have to give one month's notice in writing to the Management. A sum equal to your one months' salary will be deducted or you will need to deposit the same amount to employer in case you resign without serving a one months' notice period. It is desirable that being a teaching faculty, you do not leave the job when the academic session is in progress.
- 12) You will submit to the office the medical fitness certificate from the Registered Medical panel appointed by the DYPEECT before joining your duties.

Uzma Shaikh  
28/8/20

Page 1 of 2

- 13) You will not conduct or engage yourself in private tuitions or private coaching classes.
- 14) You will not engage yourself in any other paid job, full time, part time, honorary or otherwise during the continuance of your service in this Institute/College. You will not undertake any R & D or consultancy work and not register for any degree / diploma / certificate course without approval of the competent authority of the Trust.
- 15) You will not appear for any examinations/Admission without prior permission of the management in service.
- 16) You will not take any active part in the politics, neither involved directly or indirectly in illegal financial matters.
- 17) Your services are transferable within the trust organization only.
- 18) You will not directly or indirectly get yourself involved in any of the anti-activities against the management which may cause any harm to the institute/college or the management.
- 19) Your behavior with colleagues and entire institute/college staff should be polite, co-operative and gentle.
- 20) You will not form any union or organization amongst yourself and colleagues.
- 21) You will not process any letters either signed by you or signed jointly on any issues against the Management/Authorities without prior permission of the Principal/Director. Also, you will not approach to any authorities connected to the Institute/ College / Trust without prior permission of the Principal / Director.
- 22) You will put your grievances to the Management through Principal / Director only.
- 23) You will have to carry out the duties / work assigned to you by the Principal / Director and the Management besides your teaching work / routine work.
- 24) If you found absent continuously for more than 15 days without prior written permission from the Principal/Director, your services will stand terminated automatically and no further correspondence will be entertained thereafter.
- 25) Any information given in the application form if found incorrect contradictory at any time after the appointment, your services will be terminated forthwith, and no further correspondence will be entertained thereafter.
- 26) Progress Report: You will submit your academic progress report and other activities, seminars, presentation of papers, workshop, Self Appraisal etc. twice every year in the months of April and November.
- 27) If it is observed that your performance is not satisfactory / your behavior is not in the interest of the institute or College or trust / you commit breach of terms and conditions as mentioned in your appointment / you are found medically unfit (physically/mentally), your services shall be terminated without giving any notice period.
- 28) You will have to communicate your acceptance in writing to the Management/Director/Principal **within two weeks** from the date of receipt of Order of Appointment, failing which your appointment is liable to be withdrawal / cancelled. However, in case you need an extension of time limit for joining the duties you will have to apply in writing for grant of extension stating the reasons for the same and indicating the date on which you intend to join the duties. The request for grant of extension of time limit for joining the duties for the post shall be considered and you will be informed in the matter. The decision of the management of the **Dr. D Y Patil School of Engineering** shall be final.
- 29) If you are found guilty of violation of any terms & conditions mentioned above you will be liable for disciplinary action and punishment decided by the Management/Director/ Principal as provided in the Rules & Regulations.
- 30) In view of this appointment order, the previous appointment order/s stands cancelled.
- 31) Any dispute arises in the service will be dealt legally in jurisdiction of Pune City only.

*For Dr. D Y Patil Educational Enterprises Charitable Trust*

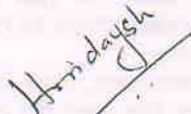
  
**Hridaysh Deshpande**  
**Authorized Signatory**



**Copy to:**

- 1 Master File DYPEECT.
- 2 Principal, Dr. D Y Patil School of Engineering  
(Two Copies: [1] Personal File [2] Accounts Section).
- 3 Chief Financial Officer, DYPEECT.



## Dr D Y PATIL EDUCATIONAL ENTERPRISES CHARITABLE TRUST

Ref.ADYPKC/SOE/AO/T/PG/2020-21/11

Date: 10.08.2020

To,  
Mr. Prasad Rangnath Gayake  
Flat No 2020, B Wing,  
Uttara Apartment,  
Shubham Tarangan  
Nashik Pune Highway, A/P- Alephata  
Tal- Junnar, Dist- Pune.

Email- [prasadcivilbe@gmail.com](mailto:prasadcivilbe@gmail.com)  
Contact- 9730717790

### Appointment Order

Mr. Prasad Rangnath Gayake,

Following your application and subsequent interview for the post of **Assistant Professor**, I am pleased to inform you that the Management has appointed you as **Assistant Professor in Civil Engineering Department at Dr. D Y Patil School of Engineering**. The terms & conditions of the appointment are as follows.

- 1) Your services are governed by the Maharashtra Universities Act, statues, ordinances, rules & regulations, code of conduct, laid down by the Savitribai Phule Pune University, Government of Maharashtra and service rules of the Trust and will be responsible to the Principal/Director of the Institute for discharge of your duties.
- 2) Your appointment is on **purely temporary basis** for a period of **Academic Year 2020-21 (i.e. upto 31<sup>st</sup> May 2021 only)** from the date of joining i.e.10<sup>th</sup> August 2020.
- 3) You will be paid consolidated monthly salary of **Rs. 35,000 Only (Rs Thirty five Thousand Only)**. No other allowances will be admissible. The salary payment will be subject to statutory deduction of taxes as applicable.
- 4) Your appointment is subject to the minimum numbers of the students and the sufficient workload prescribed for the post.
- 5) Your appointment is on purely temporary basis and will automatically come to an end on the expiry of tenure and in any such event; you shall not claim any right to be continued in the services. You shall not claim to be a regular/permanent employee of the Institute/College. At any time during the tenure of your services or after termination thereof, in any manner whatsoever, and shall not claim automatic re-appointment to the said post after expiry of the tenure of your services and you will not be eligible for any retiral benefits.
- 6) You shall submit the certified true copies of relevant documents such as birth certificate, mark sheets, experience certificates, Approval Letters, reliving certificate, Aadhar Card, PAN card, Last Pay Slip from the previous Employer before joining the duties.
- 7) You will produce 2 passport size recent photographs.
- 8) You are required to give the correct mailing address as soon as you join your duties. It will be presumed that any letter sent by Registered Post Acknowledgement Due (RPAD) or Speed Post or E-Mail on the address given, shall be deemed to have been acknowledged duly signed by you.
- 9) You are entitled Casual Leave as per Rules & Regulation of DYPEECT, subject to changes from time to time.
- 10) You are entitled for Medical Leave only after completion of one-year regular services and as per Rules & Regulation of DYPEECT, subject to changes from time to time.
- 11) If you want to leave the service during the tenure of your appointment, you will have to give one month's notice in writing to the Management. A sum equal to your one months' salary will be deducted or you will need to deposit the same amount to employer in case you resign without serving a one months' notice period. It is desirable that being a teaching faculty, you do not leave the job when the academic session is in progress.
- 12) You will submit to the office the medical fitness certificate from the Registered Medical panel appointed by the DYPEECT before joining your duties.

Page 1 of 2

*Handwritten signature and date: 10/08/2020*

- 13) You will not conduct or engage yourself in private tuitions or private coaching classes.
- 14) You will not engage yourself in any other paid job, full time, part time, honorary or otherwise during the continuance of your service in this Institute/College. You will not undertake any R & D or consultancy work and not register for any degree / diploma / certificate course without approval of the competent authority of the Trust.
- 15) You will not appear for any examinations/Admission without prior permission of the management in service.
- 16) You will not take any active part in the politics, neither involved directly or indirectly in illegal financial matters.
- 17) Your services are transferable within the trust organization only.
- 18) You will not directly or indirectly get yourself involved in any of the anti-activities against the management which may cause any harm to the institute/college or the management.
- 19) Your behavior with colleagues and entire institute/college staff should be polite, co-operative and gentle.
- 20) You will not form any union or organization amongst yourself and colleagues.
- 21) You will not process any letters either signed by you or signed jointly on any issues against the Management/Authorities without prior permission of the Principal/Director. Also, you will not approach to any authorities connected to the Institute/ College / Trust without prior permission of the Principal / Director.
- 22) You will put your grievances to the Management through Principal / Director only.
- 23) You will have to carry out the duties / work assigned to you by the Principal / Director and the Management besides your teaching work / routine work.
- 24) If you found absent continuously for more than 15 days without prior written permission from the Principal/Director, your services will stand terminated automatically and no further correspondence will be entertained thereafter.
- 25) Any information given in the application form if found incorrect contradictory at any time after the appointment, your services will be terminated forthwith, and no further correspondence will be entertained thereafter.
- 26) Progress Report: You will submit your academic progress report and other activities, seminars, presentation of papers, workshop, Self Appraisal etc. twice every year in the months of April and November.
- 27) If it is observed that your performance is not satisfactory / your behavior is not in the interest of the institute or College or trust / you commit breach of terms and conditions as mentioned in your appointment / you are found medically unfit (physically/mentally), your services shall be terminated without giving any notice period.
- 28) You will have to communicate your acceptance in writing to the Management/Director/Principal **within two weeks** from the date of receipt of Order of Appointment, failing which your appointment is liable to be withdrawal / cancelled. However, in case you need an extension of time limit for joining the duties you will have to apply in writing for grant of extension stating the reasons for the same and indicating the date on which you intend to join the duties. The request for grant of extension of time limit for joining the duties for the post shall be considered and you will be informed in the matter. The decision of the management of the **Dr. D Y Patil School of Engineering** shall be final.
- 29) If you are found guilty of violation of any terms & conditions mentioned above you will be liable for disciplinary action and punishment decided by the Management/Director/ Principal as provided in the Rules & Regulations.
- 30) In view of this appointment order, the previous appointment order/s stands cancelled.
- 31) Any dispute arises in the service will be dealt legally in jurisdiction of Pune City only.

*For Dr. D Y Patil Educational Enterprises Charitable Trust*

*Hrridaysh*  
**Hrridaysh Deshpande**  
**Authorized Signatory**



**Copy to:**

- 1 Master File DYPEECT.
- 2 Principal, Dr. D Y Patil School of Engineering  
(Two Copies: [1] Personal File [2] Accounts Section).
- 3 Chief Financial Officer, DYPEECT.



## Dr D Y PATIL EDUCATIONAL ENTERPRISES CHARITABLE TRUST

Ref.ADYPKC/SOE/AO/T/AN/2020-21/ 12

Date: 10.08.2020

To,  
Mr. Aniket Vilas Nemade  
10, Nirman Ratna Vise,  
Mala College Road,  
Nashik,  
Maharashtra  
Email- [aniketrupesh55@gmail.com](mailto:aniketrupesh55@gmail.com)  
Contact- 8956897795

### Appointment Order

Mr. Aniket Vilas Nemade,

Following your application and subsequent interview for the post of **Assistant Professor**, I am pleased to inform you that the Management has appointed you as **Assistant Professor in Civil Engineering Department at Dr. D Y Patil School of Engineering**. The terms & conditions of the appointment are as follows.

- 1) Your services are governed by the Maharashtra Universities Act, statues, ordinances, rules & regulations, code of conduct, laid down by the Savitribai Phule Pune University, Government of Maharashtra and service rules of the Trust and will be responsible to the Principal/Director of the Institute for discharge of your duties.
- 2) Your appointment is on **purely temporary basis** for a period of **Academic Year 2020-21 (i.e. upto 31<sup>st</sup> May 2021 only)** from the date of joining i.e.10<sup>th</sup> August 2020.
- 3) You will be paid consolidated monthly salary of **Rs. 35,000 Only (Rs Thirty five Thousand Only)**. No other allowances will be admissible. The salary payment will be subject to statutory deduction of taxes as applicable.
- 4) Your appointment is subject to the minimum numbers of the students and the sufficient workload prescribed for the post.
- 5) Your appointment is on purely temporary basis and will automatically come to an end on the expiry of tenure and in any such event; you shall not claim any right to be continued in the services. You shall not claim to be a regular/permanent employee of the Institute/College. At any time during the tenure of your services or after termination thereof, in any manner whatsoever, and shall not claim automatic re-appointment to the said post after expiry of the tenure of your services and you will not be eligible for any retiral benefits.
- 6) You shall submit the certified true copies of relevant documents such as birth certificate, mark sheets, experience certificates, Approval Letters, reliving certificate, Aadhar Card, PAN card, Last Pay Slip from the previous Employer before joining the duties.
- 7) You will produce 2 passport size recent photographs.
- 8) You are required to give the correct mailing address as soon as you join your duties. It will be presumed that any letter sent by Registered Post Acknowledgement Due (RPAD) or Speed Post or E-Mail on the address given, shall be deemed to have been acknowledged duly signed by you.
- 9) You are entitled Casual Leave as per Rules & Regulation of DYPEECT, subject to changes from time to time.
- 10) You are entitled for Medical Leave only after completion of one-year regular services and as per Rules & Regulation of DYPEECT, subject to changes from time to time.
- 11) If you want to leave the service during the tenure of your appointment, you will have to give one month's notice in writing to the Management. A sum equal to your one months' salary will be deducted or you will need to deposit the same amount to employer in case you resign without serving a one months' notice period. It is desirable that being a teaching faculty, you do not leave the job when the academic session is in progress.
- 12) You will submit to the office the medical fitness certificate from the Registered Medical panel appointed by the DYPEECT before joining your duties.

Page 1 of 2

Received  
R.V.  
30/8/20

- 13) You will not conduct or engage yourself in private tuitions or private coaching classes.
- 14) You will not engage yourself in any other paid job, full time, part time, honorary or otherwise during the continuance of your service in this Institute/College. You will not undertake any R & D or consultancy work and not register for any degree / diploma / certificate course without approval of the competent authority of the Trust.
- 15) You will not appear for any examinations/Admission without prior permission of the management in service.
- 16) You will not take any active part in the politics, neither involved directly or indirectly in illegal financial matters.
- 17) Your services are transferable within the trust organization only.
- 18) You will not directly or indirectly get yourself involved in any of the anti-activities against the management which may cause any harm to the institute/college or the management.
- 19) Your behavior with colleagues and entire institute/college staff should be polite, co-operative and gentle.
- 20) You will not form any union or organization amongst yourself and colleagues.
- 21) You will not process any letters either signed by you or signed jointly on any issues against the Management/Authorities without prior permission of the Principal/Director. Also, you will not approach to any authorities connected to the Institute/ College / Trust without prior permission of the Principal / Director.
- 22) You will put your grievances to the Management through Principal / Director only.
- 23) You will have to carry out the duties / work assigned to you by the Principal / Director and the Management besides your teaching work / routine work.
- 24) If you found absent continuously for more than 15 days without prior written permission from the Principal/Director, your services will stand terminated automatically and no further correspondence will be entertained thereafter.
- 25) Any information given in the application form if found incorrect contradictory at any time after the appointment, your services will be terminated forthwith, and no further correspondence will be entertained thereafter.
- 26) Progress Report: You will submit your academic progress report and other activities, seminars, presentation of papers, workshop, Self Appraisal etc. twice every year in the months of April and November.
- 27) If it is observed that your performance is not satisfactory / your behavior is not in the interest of the institute or College or trust / you commit breach of terms and conditions as mentioned in your appointment / you are found medically unfit (physically/mentally), your services shall be terminated without giving any notice period.
- 28) You will have to communicate your acceptance in writing to the Management/Director/Principal **within two weeks** from the date of receipt of Order of Appointment, failing which your appointment is liable to be withdrawal / cancelled. However, in case you need an extension of time limit for joining the duties you will have to apply in writing for grant of extension stating the reasons for the same and indicating the date on which you intend to join the duties. The request for grant of extension of time limit for joining the duties for the post shall be considered and you will be informed in the matter. The decision of the management of the **Dr. D Y Patil School of Engineering** shall be final.
- 29) If you are found guilty of violation of any terms & conditions mentioned above you will be liable for disciplinary action and punishment decided by the Management/Director/ Principal as provided in the Rules & Regulations.
- 30) In view of this appointment order, the previous appointment order/s stands cancelled.
- 31) Any dispute arises in the service will be dealt legally in jurisdiction of Pune City only.

For Dr. D Y Patil Educational Enterprises Charitable Trust

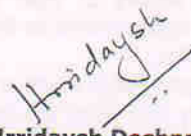
  
**Hridaysh Deshpande**  
**Authorized Signatory**



**Copy to:**

- 1 Master File DYPEECT.
- 2 Principal, Dr. D Y Patil School of Engineering  
(Two Copies: [1] Personal File [2] Accounts Section).
- 3 Chief Financial Officer, DYPEECT.



**Dr D Y PATIL GROUP**

Dr D Y PATIL GROUP OF INSTITUTIONS'S

Dr D Y PATIL TECHNICAL CAMPUS

**Dr D Y PATIL SCHOOL OF ENGINEERING**

No. DrDYP SOE/AL/SK/04042016

Date: 04/04/2016

**APPOINTMENT ORDER**

To:

**Lt Col Sanjay Karodpati**  
E Mail: [skaropati@yahoo.co.in](mailto:skaropati@yahoo.co.in)  
Mobile: +91 9923716868

Sub: Appointment to the Post of Associate Professor, Department of Civil Engineering at Dr D Y Patil School of Engineering, Pune

Sir,

With reference to the subject mentioned above, we have pleasure to inform you that you are appointed as **Associate Professor, Department of Civil Engineering** at Dr D Y Patil School of Engineering, Dr D Y Patil Knowledge City, Charholi Bk., Via Lohegaon, Pune 412 105. This appointment is subject to the following terms and conditions :

- 1) The appointment will be effective from the date of your joining the duties.
- 2) The appointment is on temporary ad-hoc basis. You will have to apply and appear for interview before a Selection Committee constituted as per norms of Pune University as and when the posts are advertised, for regularization of your appointment. The continuation of your appointment is subject to your performance, recommendations and decision of this committee.
- 3) You will be paid consolidated monthly salary of Rs 75,000 (Rs Seventy Five thousand Only). No other allowances will be admissible. The salary payment will be subject to statutory deduction of taxes as applicable.
- 4) You will have to perform duties as mentioned below:
  - a) To teach the subject/s assigned to you by the Principal/Director of the School (Theory as well as Practical) in accordance with the syllabus of the University.
  - b) To carry out any other duties as may be assigned to you from time to time by the Principal/Director of the School for smooth conduct of academic and allied co-curricular programmes and conduct of various institute and university examinations including assessment of papers.
  - c) To participate in various skill development /reorientation/ training programmes aimed at upgrading teaching capabilities of teaching faculty.

Received.  
*[Signature]*  
04 May 16



- 5) For discharge of your duties you will be responsible to the Principal/ Director of the School of Engineering and subject the rules and regulations as laid down by the University, AICTE and State Government & Trust.
- 6) While joining the duties, you will have to submit two sets of certified true copies of documents in support of your qualifications, experience, discharge certificate from previous employer and three recent passport size photographs and execute an agreement as prescribed by the Trust.
- 7) You will be required to undergo medical examination before Medical Officer attached to the Dr D Y Patil Knowledge City Campus when medical check up of staff of the Institutions in the Dr D Y Patil Knowledge City Campus is organized.
- 8) You will have to submit your correct mailing address on joining the duties and also keep the Director of the School informed about subsequent changes, if there be any. The communication sent by the institute by RPAD on the address given by you shall be deemed to have been received and acknowledged by you.
- 9) You will not conduct or engage yourself in any private tuitions or private coaching classes., will not engage yourself in any other job, paid or honorary, full time or part time while in the service of the this institute.
- 10) Your services are transferable to any other institute run by D Y Patil Group.
- 11) You will have to give three months' notice or pay/forgo three month's salary in lieu of the notice period while resigning the job. It is desirable that being a teaching faculty, you do not leave the job when the teaching session is in progress.
- 12) a) If it is observed that your performance is not satisfactory /your behavior is not in the interest of the institute/trust/ you commit breach of the terms and conditions governing your appointment/you are found medically unfit (physically/mentally), your services shall be terminated without giving any notice period.  
b) Your continuous unauthorized absence from duty for more than fifteen days shall lead to automatic termination of your services from the date from which you remain absent.  
c) If you are not selected and recommended for regularization by the Selection Committee constituted as per norms of the University, your services shall terminated with effect from the date on which the candidate selected by the said committee reports for duty.

**Yours faithfully,  
For Dr D Y Patil School of Engineering**



**Prof B G Bhandarkar  
Director Corporate Relations  
Authorised Signatory**

Copy to

1. Principal/Director Dr D Y Patil School of Engineering  
[2 copies 1. Personal File 2. Accounts Section]
2. Chief Financial Officer Head Office
3. DYPEECT Master File



DR. D. Y. PATIL GROUP

DR. D. Y. PATIL GROUP OF INSTITUTION'S  
DR. D. Y. PATIL TECHNICAL CAMPUS

## Dr D Y PATIL SCHOOL OF ENGINEERING

No. DrDYP SOE/AL/RK/01062015

Date: 01/06/2015

### APPOINTMENT ORDER

To:

**Mr Rajesh Katdare**

E Mail: kcraj1104@gmail.com

Mobile: +91 9421176868

Sub: Appointment to the Post of Assistant Professor, Department of Civil Engineering at Dr D Y Patil School of Engineering, Pune

Sir,

With reference to the subject mentioned above, we have pleasure to inform you that you are appointed as **Assistant Professor, Department of Civil Engineering** at Dr D Y Patil School of Engineering, Dr D Y Patil Knowledge City, Charholi Bk., Via Lohegaon, Pune 412 105. This appointment is subject to the following terms and conditions :

- 1) The appointment will be effective from the date of your joining the duties.
- 2) The appointment is on temporary ad-hoc basis. You will have to apply and appear for interview before a Selection Committee constituted as per norms of Pune University as and when the posts are advertised, for regularization of your appointment. The continuation of your appointment is subject to your performance, recommendations and decision of this committee.
- 3) You will be paid consolidated monthly salary of Rs 85000 (Rs Eighty Five Thousand Only). No other allowances will be admissible. The salary payment will be subject to statutory deduction of taxes as applicable.
- 4) You will have to perform duties as mentioned below:
  - a) To teach the subject/s assigned to you by the Principal/Director of the School (Theory as well as Practical) in accordance with the syllabus of the University.
  - b) To carry out any other duties as may be assigned to you from time to time by the Principal/Director of the School for smooth conduct of academic and allied co-curricular programmes and conduct of various institute and university examinations including assessment of papers.
  - c) To participate in various skill development /reorientation/ training programmes aimed at upgrading teaching capabilities of teaching faculty.
- 5) For discharge of your duties you will be responsible to the Principal/ Director of the School of Engineering and subject the rules and regulations as laid down by the University, AICTE and State Government & Trust.
- 6) While joining the duties, you will have to submit two sets of certified true copies of documents in support of your qualifications, experience, discharge certificate from previous employer and three recent passport size photographs and execute an agreement as prescribed by the Trust.

Received  
G. Patil  
11/7/15

Recd  
Att  
22/06/2015

- 7) You will be required to undergo medical examination before Medical Officer attached to the Dr D Y Patil Knowledge City Campus when medical check up of staff of the Institutions in the Dr D Y Patil Knowledge City Campus is organized.
- 8) You will have to submit your correct mailing address on joining the duties and also keep the Director of the School informed about subsequent changes, if there be any. The communication sent by the institute by RPAD on the address given by you shall be deemed to have been received and acknowledged by you.
- 9) You will not conduct or engage yourself in any private tuitions or private coaching classes., will not engage yourself in any other job, paid or honorary, full time or part time while in the service of the this institute.
- 10).Your services are transferable to any other institute run by D Y Patil Group.
- 11) You will have to give three months' notice or pay/forgo three month's salary in lieu of the notice period while resigning the job. It is desirable that being a teaching faculty, you do not leave the job when the teaching session is in progress.
- 12) a) If it is observed that your performance is not satisfactory /your behavior is not in the interest of the institute/trust/ you commit breach of the terms and conditions governing your appointment/you are found medically unfit (physically/mentally), your services shall be terminated without giving any notice period.  
b) Your continuous unauthorized absence from duty for more than fifteen days shall lead to automatic termination of your services from the date from which you remain absent.  
c) If you are not selected and recommended for regularization by the Selection Committee constituted as per norms of the University, your services shall terminated with effect from the date on which the candidate selected by the said committee reports for duty.

**Yours faithfully,  
For Dr D Y Patil School of Engineering**

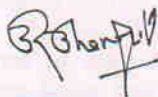

**Prof B G Bhandarkar  
Director Corporate Relations  
Authorised Signatory**

Copy to

1. Principal/Director Dr D Y Patil School of Engineering  
[2 copies 1. Personal File 2. Accounts Section]
2. Chief Financial Officer Head Office
3. DYPEECT Master File



**D Y PATIL GROUP**

**Dr D Y PATIL EDUCATIONAL ENTERPRISES CHARITABLE TRUST**

No.DrDYPEECT/IC/APP/SoE/ 13-023

Date : .01.02.2013

**APPOINTMENT ORDER**

To:

✓ **Shri.Ramakant Dagadu Koshti**  
Mobile : +91 9423938633  
E Mail : ramakantkoshti1975@gmail.com

**Sub : Appointment to the Post of Lecturer in Civil Engineering**  
at Dr.D.Y.Patil School of Engineering ,Pune

Sir,

With reference to the subject mentioned above, we have pleasure to inform you that you are appointed as **Lecturer in Civil Engineering** at Dr.D.Y.Patil School of Engineering at Dr.D.Y.Patil Knowledge City, Charholi Bk., Via Lohegaon, Pune 412 105. This appointment is subject to the following terms and conditions :

- 1) The appointment will be effective from the date of your joining the duties .
- 2) The appointment is on temporary ad-hoc basis .You will have to apply and appear for interview before a Selection Committee constituted as per norms of Pune University as and when the posts are advertised, for regularization of your appointment. The continuation of your appointment is subject to your performance , recommendations and decision of this committee.
- 3) You will be paid consolidated salary of Rs.40 ,000/-(RsForty thousand only )per month .No other allowances will be admissible.The salary payments will be subject to deduction of statutory taxes as applicable.
- 4) You will have to perform duties as mentioned below
  - a) To teach the subject/s assigned to you by the Director of the School (Theory as well as Practicals ) in accordance with the syllabus of the University.
  - b) To carry out any other duties as may be assigned to you from time to time by the Director of the School for smooth conduct of academic and allied co-curricular programmes and conduct of various institute and university examinations including assessment of papers.
  - c) To participate in various skill development /reorientation / training programmes aimed at upgrading teaching capabilities of teaching faculty.
- 5) For discharge of your duties you will be responsible to the Director of the School of Engineering and subject to the rules and regulations as laid down by the University, AICTE and State Government.
- 6) While joining the duties, you will have to submit two sets of certified true copies of documents in support of your qualifications , experience, discharge certificate from previous employer and three recent passport size photographs and execute an agreement as prescribed by the Trust..

- 7) You will be required to undergo medical examination before Medical Officer attached to the Technical Campus when medical check up of staff of the Institutions under Technical Campus is organized .
- 8) You will have to submit your correct mailing address on joining he duties and also keep the Director of the School informed about subsequent changes, if there be any. The communication sent by the institute by RPAD on the address given by you shall be deemed to have been received and acknowledged by you.
- 9) You will not conduct or engage yourself in any private tuitions or private coaching classes., will not engage yourself in any other job, paid or honorary, full time or part time while in the service of the this institute.
- 10) Your services are transferable to any other institute run by D.Y.Patil Group.
- 11) You will have to give one month's notice or pay/forgo one month's salary in lieu of the notice period while resigning the job.It is desirable that being a teaching faculty , you do not leave the job when the teaching session is in progress.
- 12) a) If it is observed that your performance is not satisfactory /your behaviour is not in the interest of the institute/trust/ you commit breach of the terms and conditions governing your appointment/you are found medically unfit (physically/mentally) ,your services shall be terminated without giving any notice period.  
b) Your continuous unauthorized absence from duty for more than fifteen days shall lead to automatic termination of your services from the date from which you remain absent.  
c) If you are not selected and recommended for regularization by the Selection Committee constituted as per norms of the University, your services shall terminated with effect from the date on which the candidate selected by the said committee reports for duty.

Yours faithfully,

**For Dr.D.Y.Patil Educational Enterprises Charitable Trust**

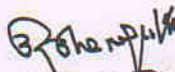
  
**Prof.B.G.Bhandarkar**  
**Director Corporate Relations**  
**Authorised Signatory**

Copy to

- 1 Director Dr.D.Y.Patil School of Engineering  
[ 2 copies 1 .Personal File 2.Accounts Section ]
- 2 Chief Financial Officer Head office
- 3 DYPEECT Master File



## DR D Y PATIL EDUCATIONAL ENTERPRISES CHARITABLE TRUST

Dr. D. Y. Patil Knowledge City, Charholi Bk, Via Lohegaon, Pune 412 105

[Mumbai Public Trust Registration No.E 4417 Pune : 11.10.2005]

Phone (020) 3061 2700 • Fax (020) 3061 2718

No.DrDYPEECT/SoE/APP/1131

Date : 25.7.2011

### D.Y.PATIL GROUP OF INSTITUTIONS APPOINTMENT ORDER

To:

**Shri.K.S.Bahubali**

Sub : Appointment to the Post of **Assistant Professor of Electronics & Telecom I Engineering**  
at Dr.D.Y.Patil School of Engineering Pune

Sir,

With reference to the subject mentioned above, we have pleasure to inform you that you are appointed as **Assistant Professor of Electronics & Telecom Engineering** at Dr.D.Y.Patil School of Engineering at Dr.D.Y.Patil Knowledge City, Charholi Bk.,Via Lohegaon, Pune 412 105.This appointment is subject to the following terms and conditions :

- 1) The appointment will be effective from the date of your joining the duties .
- 2) The appointment is on ad-hoc basis .You will have to apply and appear for interview before a Selection Committee constituted as per norms of Pune University as and when the posts are advertised, for regularization of your appointment. The continuation of your appointment is subject to your performance and recommendations & decision of this committee.
- 3) You will be paid pay of Rs.33150/- ( Rs. Thirty three thousand and one hundred fifty only ) plus Academic Grade Pay (AGP) of Rs. 6000/- ( Rs. six thousand only ) per month in Sixth Pay Commission Pay Band of Rs.15600-39100 and other allowances as prescribed by Government of Maharashtra / AICTE from time to time. The salary payments will be subject to deduction of statutory taxes as applicable.
- 4) You will have to perform duties as mentioned below :
  - a) To teach the subject/s assigned to you by Head of Department/ Director of the Institute ( theory as well as practicals ) in accordance with the syllabus of the University .
  - b) To carry out any other duties as may be assigned to you from time to time by Head of Department/Head of Institute for smooth conduct of academic and allied co-curriculum programmes as well as conduct of various institute and university examinations.
  - g) To participate in various skill development /reorientation / training programmes aimed at upgrading teaching capabilities of teaching faculty.
- 5) For discharge of your duties you will be responsible to the Director of the School of Engineering and subject to the rules and regulations as laid down by the University, AICTE and State Government.

Received  
Shri K.S. Bahubali  
2/8/2011

- 6) While joining the duties, you will have to submit two sets of certified true copies of documents in support of your qualifications , experience, discharge certificate from previous employer and three recent passport size photographs and execute an agreement as prescribed by the Trust..
- 7) You will be required to undergo medical examination before Medical Officer attached to the Integrated Campus when medical check up of staff of the Institutions under Technical Campus is organized .
- 8) You will have to submit your correct mailing address on joining he duties and also keep the Director of the institute informed about subsequent changes, if there be any. The communication sent by the institute by RPAD on the address given by you shall be deemed to have been received and acknowledged by you.
- 9) You will not conduct or engage yourself in any private tuitions or private coaching classes., will not engage yourself in any other job, paid or honorary, full time or part time while in the service of the this institute.
- 10) Your services are transferable to any other institute run by D.Y.Patil Group.
- 11) You will have to give one month's notice or pay/forgo one month's salary in lieu of the notice period while resigning the job. It is desirable that being a teaching faculty , you do not leave the job when the teaching session is in progress.
- 12) a) If it is observed that your performance is not satisfactory /your behaviour is not in the interest of the institute/trust/ you commit breach of the terms and conditions governing your appointment/you are found medically unfit (physically/mentally) ,your services shall be terminated without giving any notice period.  
b) Your continuous unauthorized absence from duty for more than fifteen days shall lead to automatic termination of your services from the date from which you remain absent.  
c) If you are not selected and recommended for regularization by the Selection Committee constituted as per norms of the University, your services shall terminated with effect from the date on which the candidate selected by the said committee reports for duty.

Yours faithfully,

For Dr.D.Y.Patil Educational Enterprises Charitable Trust



**Prof.B.G.Bhandarkar**  
**Director Corporate Relations**  
**Authorised Signatory**

Copy to

- 1 Director Dr.D.Y.Patil School of Engineering  
[ 2 copies ✓ Personal File 2.Accounts Section ]
- 2 Chief Financial Officer Head office
- 3 DYPEECT Master File



D Y PATIL GROUP

**Dr D Y PATIL EDUCATIONAL ENTERPRISES CHARITABLE TRUST**

No.DrDYPEECT/IC/APP/SoE/ 13-042

Date: 17.6.2013

**APPOINTMENT ORDER**

To:

**Mr.Riyaj latifuddin Kazi**  
E Mail : kajiriyaj@rediffmail.com  
Mobile : +91 98818 39335

**Sub : Appointment to the Post of Asstt Prof of Electronics & Telecommunications Engineering at Dr.D.Y.Patil School of Engineering , Pune**

Sir ,

With reference to the subject mentioned above, we have pleasure to inform you that you are appointed as **Asstt. Professor of Electronics & Telecommunications Engineering** at Dr.D.Y.Patil School of Engineering at Dr.D.Y.Patil Knowledge City, Charholi Bk., Via Lohegaon, Pune 412 105. This appointment is subject to the following terms and conditions :

- 1) The appointment will be effective from the date of your joining the duties .
- 2) The appointment is on temporary ad-hoc basis .You will have to apply and appear for interview before a Selection Committee constituted as per norms of Pune University as and when the posts are advertised, for regularization of your appointment. The continuation of your appointment is subject to your performance , recommendations and decision of this committee.
- 3) You will be paid pay of Rs.27,900/- ( Rs. Twenty seven thousand nine hundred only ) plus Academic Grade Pay (AGP) of Rs. 6000/- ( Rs. six thousand only ) per month in Sixth Pay Commission Pay Band of Rs.15600-39100 and other allowances as prescribed by the Trust from time to time. The salary payments will be subject to deduction of statutory taxes as applicable.
- 4) You will have to perform duties as mentioned below
  - a) To teach the subject/s assigned to you by the Principal/Director of the School (Theory as well as Practicals ) in accordance with the syllabus of the University.
  - b) To carry out any other duties as may be assigned to you from time to time by the Principal/Director of the School for smooth conduct of academic and allied co-curricular programmes and conduct of various institute and university examinations including assessment of papers.
  - c) To participate in various skill development /reorientation / training programmes aimed at upgrading teaching capabilities of teaching faculty.
- 5) For discharge of your duties you will be responsible to the Principal/ Director of the School of Engineering and subject the rules and regulations as laid down by the University, AICTE and State Government & Trust .
- 6) While joining the duties, you will have to submit two sets of certified true copies of documents in support of your qualifications , experience, discharge certificate from previous employer and three recent passport size photographs and execute an agreement as prescribed by the Trust..

Received  
@Luj  
(R.L.Kazi)  
01-07-2013

Received  
@Luj  
01/07/13



- 7) You will be required to undergo medical examination before Medical Officer attached to the Dr.D.Y.Patil Knowledge City Campus when medical check up of staff of the Institutions in the Dr.D.Y.Patil Knowledge City Campus is organized .
- 8) You will have to submit your correct mailing address on joining he duties and also keep the Director of the School informed about subsequent changes, if there be any. The communication sent by the institute by RPAD on the address given by you shall be deemed to have been received and acknowledged by you.
- 9) You will not conduct or engage yourself in any private tuitions or private coaching classes., will not engage yourself in any other job, paid or honorary, full time or part time while in the service of the this institute.
- 10) Your services are transferable to any other institute run by D.Y.Patil Group.
- 11) You will have to give one month's notice or pay/forgo one month's salary in lieu of the notice period while resigning the job.It is desirable that being a teaching faculty , you do not leave the job when the teaching session is in progress.
- 12) a) If it is observed that your performance is not satisfactory /your behaviour is not in the interest of the institute/trust/ you commit breach of the terms and conditions governing your appointment/you are found medically unfit (physically/mentally) ,your services shall be terminated without giving any notice period.  
b) Your continuous unauthorized absence from duty for more than fifteen days shall lead to automatic termination of your services from the date from which you remain absent.  
c) If you are not selected and recommended for regularization by the Selection Committee constituted as per norms of the University, your services shall terminated with effect from the date on which the candidate selected by the said committee reports for duty.

Yours faithfully,

For Dr.D.Y.Patil Educational Enterprises Charitable Trust

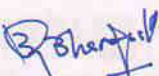
  
Prof.B.G.Bhandarkar  
Director Corporate Relations  
Authorised Signatory

Copy to

- 1 Principal/Director Dr.D.Y.Patil School of Engineering  
[ 2 copies ✓ Personal File 2.Accounts Section ]
- 2 Chief Financial Officer Head office
- 3 DYPEECT Master File

*Handwritten notes:*  
8/1/18

*Handwritten notes:*  
21/1/18



## DR D Y PATIL EDUCATIONAL ENTERPRISES CHARITABLE TRUST

Dr. D. Y. Patil Knowledge City, Charholi Bk, Via Lohegaon, Pune 412 105

[Mumbai Public Trust Registration No.E 4417 Pune : 11.10.2005]

Phone (020) 3061 2700 • Fax (020) 3061 2718

No.DrDYPEECT/SoE/APP/ 1132,

Date : 25.7.2011

### D.Y.PATIL GROUP OF INSTITUTIONS APPOINTMENT ORDER

To:

**Ms.Rashmi Mahajan**

Sub : Appointment to the Post of **Assistant Professor of Electronics & Telecom Engineering**  
at Dr.D.Y.Patil School of Engineering Pune

Madam,

With reference to the subject mentioned above, we have pleasure to inform you that you are appointed as **Assistant Professor of Electronics & Telecom Engineering** at Dr.D.Y.Patil School of Engineering at Dr.D.Y.Patil Knowledge City, Charholi Bk.,Via Lohegaon, Pune 412 105.This appointment is subject to the following terms and conditions :

- 1) The appointment will be effective from the date of your joining the duties .
- 2) The appointment is on ad-hoc basis .You will have to apply and appear for interview before a Selection Committee constituted as per norms of Pune University as and when the posts are advertised, for regularization of your appointment. The continuation of your appointment is subject to your performance and recommendations & decision of this committee.
- 3) You will be paid pay of Rs.20800 ( Rs. twenty thousand and eight hundred only ) plus Academic Grade Pay (AGP) of Rs. 6000/- ( Rs. six thousand only ) per month in Sixth Pay Commission Pay Band of Rs.15600-39100 and other allowances as prescribed by Government of Maharashtra / AICTE from time to time. The salary payments will be subject to deduction of statutory taxes as applicable.
- 4) You will have to perform duties as mentioned below :
  - a) To teach the subject/s assigned to you by Head of Department/ Director of the Institute ( theory as well as practicals ) in accordance with the syllabus of the University .
  - b) To carry out any other duties as may be assigned to you from time to time by Head of Department/Head of Institute for smooth conduct of academic and allied co-curriculum programmes as well as conduct of various institute and university examinations.
  - h) To participate in various skill development /reorientation / training programmes aimed at upgrading teaching capabilities of teaching faculty.
- 5) For discharge of your duties you will be responsible to the Director of the School of Engineering and subject to the rules and regulations as laid down by the University, AICTE and State Government.

Received  
@Rashmi

- 6) While joining the duties, you will have to submit two sets of certified true copies of documents in support of your qualifications , experience, discharge certificate from previous employer and three recent passport size photographs and execute an agreement as prescribed by the Trust..
- 7) You will be required to undergo medical examination before Medical Officer attached to the Integrated Campus when medical check up of staff of the Institutions under Technical Campus is organized .
- 8) You will have to submit your correct mailing address on joining he duties and also keep the Director of the institute informed about subsequent changes, if there be any. The communication sent by the institute by RPAD on the address given by you shall be deemed to have been received and acknowledged by you.
- 9) You will not conduct or engage yourself in any private tuitions or private coaching classes., will not engage yourself in any other job, paid or honorary, full time or part time while in the service of the this institute.
- 10) Your services are transferable to any other institute run by D.Y.Patil Group.
- 11) You will have to give one month's notice or pay/forgo one month's salary in lieu of the notice period while resigning the job. It is desirable that being a teaching faculty , you do not leave the job when the teaching session is in progress.
- 12) a) If it is observed that your performance is not satisfactory /your behaviour is not in the interest of the institute/trust/ you commit breach of the terms and conditions governing your appointment/you are found medically unfit (physically/mentally) ,your services shall be terminated without giving any notice period.  
b) Your continuous unauthorized absence from duty for more than fifteen days shall lead to automatic termination of your services from the date from which you remain absent.  
c) If you are not selected and recommended for regularization by the Selection Committee constituted as per norms of the University, your services shall terminated with effect from the date on which the candidate selected by the said committee reports for duty.

Yours faithfully,

**For Dr.D.Y.Patil Educational Enterprises Charitable Trust**

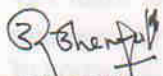

**Prof.B.G.Bhandarkar**  
**Director Corporate Relations**  
**Authorised Signatory**

Copy to

- 1 Director Dr.D.Y.Patil School of Engineering  
[ 2 copies ✓ 1. Personal File 2. Accounts Section ]
- 2 Chief Financial Officer Head office
- 3 DYPEECT Master File



**Dr D Y PATIL GROUP**  
Dr D Y PATIL GROUP OF INSTITUTIONS'S  
Dr D Y PATIL TECHNICAL CAMPUS

## Dr D Y PATIL SCHOOL OF ENGINEERING

No. DrDYPSOE/AL/SMK/19072016

Date: 19/07/2016

### APPOINTMENT ORDER

To:

**Dr Sanjay Mahadev Koli**

Flat No 302, Prithaviraj Resi, Near Rajas Society,

Katraj Kondhwa Road, Katraj Pune

E Mail: sanjyko12@yahoo.com

Mobile: +91 988 1045939

Sub: Appointment to the Post of Professor, Department of Electronics & Telecommunication Engineering at Dr D Y Patil School of Engineering, Pune

Sir,

With reference to the subject mentioned above, we have pleasure to inform you that you are appointed as **Professor, Department of Electronics & Telecommunication Engineering** at Dr D Y Patil School of Engineering, Dr D Y Patil Knowledge City, Charholi Bk., Via Lohegaon, Pune 412 105. This appointment is subject to the following terms and conditions :

- 1) The appointment will be effective from the date of your joining the duties.
- 2) The appointment is on temporary ad-hoc basis. You will have to apply and appear for interview before a Selection Committee constituted as per norms of Pune University as and when the posts are advertised, for regularization of your appointment. The continuation of your appointment is subject to your performance, recommendations and decision of this committee.
- 3) You will be paid consolidated monthly salary of Rs 1,20,000 (Rs One Lac Twenty Thousand Only). No other allowances will be admissible. The salary payment will be subject to statutory deduction of taxes as applicable.
- 4) You will have to perform duties as mentioned below:
  - a) To teach the subject/s assigned to you by the Principal/Director of the School (Theory as well as Practical) in accordance with the syllabus of the University.
  - b) To carry out any other duties as may be assigned to you from time to time by the Principal/Director of the School for smooth conduct of academic and allied co-curricular programmes and conduct of various institute and university examinations including assessment of papers.
  - c) To participate in various skill development /reorientation/ training programmes aimed at upgrading teaching capabilities of teaching faculty.

*Received  
Patil*

- 5) For discharge of your duties you will be responsible to the Principal/ Director of the School of Engineering and subject the rules and regulations as laid down by the University, AICTE and State Government & Trust.
- 6) While joining the duties, you will have to submit two sets of certified true copies of documents in support of your qualifications, experience, discharge certificate from previous employer and three recent passport size photographs and execute an agreement as prescribed by the Trust.
- 7) You will be required to undergo medical examination before Medical Officer attached to the Dr D Y Patil Knowledge City Campus when medical check up of staff of the Institutions in the Dr D Y Patil Knowledge City Campus is organized.
- 8) You will have to submit your correct mailing address on joining the duties and also keep the Director of the School informed about subsequent changes, if there be any. The communication sent by the institute by RPAD on the address given by you shall be deemed to have been received and acknowledged by you.
- 9) You will not conduct or engage yourself in any private tuitions or private coaching classes., will not engage yourself in any other job, paid or honorary, full time or part time while in the service of the this institute.
- 10) Your services are transferable to any other institute run by D Y Patil Group.
- 11) You will have to give one months' notice or pay/forgo one month's salary in lieu of the notice period while resigning the job. It is desirable that being a teaching faculty, you do not leave the job when the teaching session is in progress.
- 12) a) If it is observed that your performance is not satisfactory /your behavior is not in the interest of the institute/trust/ you commit breach of the terms and conditions governing your appointment/you are found medically unfit (physically/mentally), your services shall be terminated without giving any notice period.  
b) Your continuous unauthorized absence from duty for more than fifteen days shall lead to automatic termination of your services from the date from which you remain absent.  
c) If you are not selected and recommended for regularization by the Selection Committee constituted as per norms of the University, your services shall terminated with effect from the date on which the candidate selected by the said committee reports for duty.

**Yours faithfully,  
For Dr D Y Patil School of Engineering**

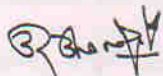

**Prof B G Bhandarkar  
Director Corporate Relations  
Authorised Signatory**

Copy to

1. Principal/Director Dr D Y Patil School of Engineering  
[2 copies 1. Personal File 2. Accounts Section]
2. Chief Financial Officer Head Office
3. DYPEECT Master File



**DR D Y PATIL EDUCATIONAL ENTERPRISES CHARITABLE TRUST**

No.DrDYPEECT/IC/APP/SoE/14-005

Date : 6.1.2014

**APPOINTMENT ORDER**

To:

**Mr.Nishikant Surwade**

E Mail : b nishikant@rediffmail.com

Mobile : +91 96899 07455

**Sub : Appointment to the Post of Asstt Prof of Electronics & Telecommunications Engineering at Dr.D.Y.Patil School of Engineering , Pune**

Sir ,

With reference to the subject mentioned above, we have pleasure to inform you that you are appointed as **Asstt. Professor of Electronics & Telecommunications Engineering** at Dr.D.Y.Patil School of Engineering at Dr.D.Y.Patil Knowledge City, Charholi Bk., Via Lohegaon, Pune 412 105. This appointment is subject to the following terms and conditions :

- 1) The appointment will be effective from the date of your joining the duties .
- 2) The appointment is on temporary ad-hoc basis .You will have to apply and appear for interview before a Selection Committee constituted as per norms of Pune University as and when the posts are advertised, for regularization of your appointment. The continuation of your appointment is subject to your performance , recommendations and decision of this committee.
- 3) You will be paid pay of Rs 20150 /-( Rs.Twenty thousand one hundred & fifty only ) plus Academic Grade Pay (AGP) of Rs. 6000/-( Rs. Six thousand only ) per month in Sixth Pay Commission Pay Band of Rs.15600-39100 and other allowances as prescribed by the Trust from time to time. Plus special pay of Rs.5,000/- (rs.five thousand only ) pm.The salary payments will be subject to deduction of statutory taxes as applicable.
- 4) You will have to perform duties as mentioned below
  - a) To teach the subject/s assigned to you by the Principal/Director of the School (Theory as well as Practicals ) in accordance with the syllabus of the University.
  - b) To carry out any other duties as may be assigned to you from time to time by the Principal/Director of the School for smooth conduct of academic and allied co-curricular programmes and conduct of various institute and university examinations including assessment of papers.
  - c) To participate in various skill development /reorientation / training programmes aimed at upgrading teaching capabilities of teaching faculty.
- 5) For discharge of your duties you will be responsible to the Principal/ Director of the School of Engineering and subject the rules and regulations as laid down by the University, AICTE and State Government & Trust .
- 6) While joining the duties, you will have to submit two sets of certified true copies of documents in support of your qualifications , experience, discharge certificate from previous employer and three recent passport size photographs and execute an agreement as prescribed by the Trust..

*Ravi*  
  
\_\_\_\_\_

- 7) You will be required to undergo medical examination before Medical Officer attached to the .Dr.D.Y.Patil Knowledge City Campus when medical check up of staff of the Institutions in the Dr.D.Y.Patil Knowledge City Campus is organized .
- 8) You will have to submit your correct mailing address on joining he duties and also keep the Director of the School informed about subsequent changes, if there be any. The communication sent by the institute by RPAD on the address given by you shall be deemed to have been received and acknowledged by you.
- 9) You will not conduct or engage yourself in any private tuitions or private coaching classes., will not engage yourself in any other job, paid or honorary, full time or part time while in the service of the this institute.
- 10) Your services are transferable to any other institute run by D.Y.Patil Group.
- 11) You will have to give one month's notice or pay/forgo one month's salary in lieu of the notice period while resigning the job.It is desirable that being a teaching faculty , you do not leave the job when the teaching session is in progress.
- 12) a) If it is observed that your performance is not satisfactory /your behaviour is not in the interest of the institute/trust/ you commit breach of the terms and conditions governing your appointment/you are found medically unfit (physically/mentally) ,your services shall be terminated without giving any notice period.  
b) Your continuous unauthorized absence from duty for more than fifteen days shall lead to automatic termination of your services from the date from which you remain absent.  
c) If you are not selected and recommended for regularization by the Selection Committee constituted as per norms of the University, your services shall terminated with effect from the date on which the candidate selected by the said committee reports for duty.

Yours faithfully,

**For Dr.D.Y.Patil Educational Enterprises Charitable Trust**

  
**Prof.B.G.Bhandarkar**  
**Director Corporate Relations**  
**Authorised Signatory**

Copy to

- ✓ 1 Principal/Director Dr.D.Y.Patil School of Engineering  
[ 2 copies ✓1 .Personal File ✓2.Accounts Section ]
- 2 Chief Financial Officer Head office
- 3 DYPEECT Master File



DR D Y PATIL GROUP OF INSTITUTION'S  
DR D Y PATIL TECHNICAL CAMPUS

## Dr D Y PATIL SCHOOL OF ENGINEERING

No. DrDYPSOE/AL/PK/01062015

Date: 01/06/2015

### APPOINTMENT ORDER

To:

**Mrs Prajakta Khairnar**

E Mail: khairnarprajakta@yahoo.co.in

Mobile: +91 9423022565

Sub: Appointment to the Post of Assistant Professor, Department of Electronics & Telecommunication Engineering at Dr D Y Patil School of Engineering, Pune

Madam  
Sir,

With reference to the subject mentioned above, we have pleasure to inform you that you are appointed as **Assistant Professor, Department of Electronics & Telecommunication Engineering** at Dr D Y Patil School of Engineering, Dr D Y Patil Knowledge City, Charholi Bk., Via Lohegaon, Pune 412 105. This appointment is subject to the following terms and conditions :

- 1) The appointment will be effective from the date of your joining the duties.
- 2) The appointment is on temporary ad-hoc basis. You will have to apply and appear for interview before a Selection Committee constituted as per norms of Pune University as and when the posts are advertised, for regularization of your appointment. The continuation of your appointment is subject to your performance, recommendations and decision of this committee.
- 3) You will be paid a monthly remuneration which includes basic pay of Rs 15600 (Rs Fifteen Thousand Six Hundred only) plus Academic Grade Pay (AGP) of Rs. 6,000 (Rs Six Thousand) in Sixth Pay Commission Pay Band of Rs 15,600 - 39100 and other allowances as prescribed by the Trust from time to time. The salary payments will be subject to deduction of statutory taxes as applicable.
- 4) You will have to perform duties as mentioned below:
  - a) To teach the subject/s assigned to you by the Principal/Director of the School (Theory as well as Practical) in accordance with the syllabus of the University.
  - b) To carry out any other duties as may be assigned to you from time to time by the Principal/Director of the School for smooth conduct of academic and allied co-curricular programmes and conduct of various institute and university examinations including assessment of papers.
  - c) To participate in various skill development /reorientation/ training programmes aimed at upgrading teaching capabilities of teaching faculty.
- 5) For discharge of your duties you will be responsible to the Principal/ Director of the School of Engineering and subject the rules and regulations as laid down by the University, AICTE and State Government & Trust.

Received  
Gyapal  
11/7/2015

Rhairnar



- 6) While joining the duties, you will have to submit two sets of certified true copies of documents in support of your qualifications, experience, discharge certificate from previous employer and three recent passport size photographs and execute an agreement as prescribed by the Trust.
- 7) You will be required to undergo medical examination before Medical Officer attached to the Dr D Y Patil Knowledge City Campus when medical check up of staff of the Institutions in the Dr D Y Patil Knowledge City Campus is organized.
- 8) You will have to submit your correct mailing address on joining the duties and also keep the Director of the School informed about subsequent changes, if there be any. The communication sent by the institute by RPAD on the address given by you shall be deemed to have been received and acknowledged by you.
- 9) You will not conduct or engage yourself in any private tuitions or private coaching classes., will not engage yourself in any other job, paid or honorary, full time or part time while in the service of the this institute.
- 10) Your services are transferable to any other institute run by D Y Patil Group.
- 11) You will have to give three months' notice or pay/forgo three month's salary in lieu of the notice period while resigning the job. It is desirable that being a teaching faculty, you do not leave the job when the teaching session is in progress.
- 12) a) If it is observed that your performance is not satisfactory /your behavior is not in the interest of the institute/trust/ you commit breach of the terms and conditions governing your appointment/you are found medically unfit (physically/mentally), your services shall be terminated without giving any notice period.  
b) Your continuous unauthorized absence from duty for more than fifteen days shall lead to automatic termination of your services from the date from which you remain absent.  
c) If you are not selected and recommended for regularization by the Selection Committee constituted as per norms of the University, your services shall terminated with effect from the date on which the candidate selected by the said committee reports for duty.

**Yours faithfully,  
For Dr D Y Patil School of Engineering**

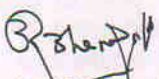
  
**Prof B G Bhandarkar  
Director Corporate Relations  
Authorised Signatory**

Copy to

1. Principal/Director Dr D Y Patil School of Engineering  
[2 copies 1. Personal File 2. Accounts Section]
2. Chief Financial Officer Head Office
3. DYPECT Master File



D Y PATIL GROUP

**Dr D Y PATIL EDUCATIONAL ENTERPRISES CHARITABLE TRUST**

No.DrDYPEECT/IC/APP/SoE/ 13-094

Date : . 20.8.2013

**APPOINTMENT ORDER**

To:

**Ms.Khawate Swati Shailesh**

E Mail : swati\_khawate@yahoo.co.in

Mobile : +91 98601 29848

**Sub : Appointment to the Post of Lecturer in E & TC Engineering**  
at Dr.D.Y.Patil School of Engineering Pune

Madam ,

With reference to the subject mentioned above, we have pleasure to inform you that you are appointed as **Lecturer in E & TC Engineering** at Dr.D.Y.Patil School of Engineering at Dr.D.Y.Patil Knowledge City, Charholi Bk., Via Lohegaon, Pune 412 105. This appointment is subject to the following terms and conditions :

- 1) The appointment will be effective from the date of your joining the duties .
- 2) The appointment is on temporary ad-hoc basis .You will have to apply and appear for interview before a Selection Committee constituted as per norms of Pune University as and when the posts are advertised, for regularization of your appointment. The continuation of your appointment is subject to your performance , recommendations and decision of this committee.
- 3) You will be paid basic salary of Rs.8,000- (Rs.Eight thousand only ) in the pay scale of Rs.8000-275-13500 and other allowances as prescribed by the Trust from time to time.. The salary payments will be subject to deduction of statutory taxes as applicable
- 4) You will have to perform duties as mentioned below
  - a) To teach the subject/s assigned to you by the Principal/ Director of the School (Theory as well as Practicals ) in accordance with the syllabus of the University.
  - b) To carry out any other duties as may be assigned to you from time to time by the Principal/Director of the School for smooth conduct of academic and allied co-curricular programmes and conduct of various institute and university examinations including assessment of papers.
  - c) To participate in various skill development /reorientation / training programmes aimed at upgrdaging teaching capabilities of teaching faculty.
- 5) For discharge of your duties you will be responsible to the Principal/ Director of the School of Engineering and subject the rules and regulations as laid down by the University, AICTE , State Government and the Trust.
- 6) While joining the duties, you will have to submit two sets of certified true copies of documents in support of your qualifications , experience, discharge certificate from previous employer and three recent passport size photographs and execute an agreement as prescribed by the Trust..

Received  
20/8/13

Swati Khawate

Received on  
21/9/2013

- 7) You will be required to undergo medical examination before Medical Officer attached to the Dr.D.Y.Patil Knowledge City when medical check up of staff of the Institutions under Dr.D.Y.Patil Knowledge City Campus is organized .
- 8) You will have to submit your correct mailing address on joining he duties and also keep the Principal/ Director of the School informed about subsequent changes, if there be any. The communication sent by the institute by RPAD on the address given by you shall be deemed to have been received and acknowledged by you.
- 9) You will not conduct or engage yourself in any private tuitions or private coaching classes., will not engage yourself in any other job, paid or honorary, full time or part time while in the service of the this institute.
- 10) Your services are transferable to any other institute run by D.Y.Patil Group.
- 11) You will have to give one month's notice or pay/forgo one month's salary in lieu of the notice period while resigning the job.It is desirable that being a teaching faculty , you do not leave the job when the teaching session is in progress.
- 12) a) If it is observed that your performance is not satisfactory /your behaviour is not in the interest of the institute/trust/ you commit breach of the terms and conditions governing your appointment/you are found medically unfit (physically/mentally) ,your services shall be terminated without giving any notice period.  
b) Your continuous unauthorized absence from duty for more than fifteen days shall lead to automatic termination of your services from the date from which you remain absent.  
c) If you are not selected and recommended for regularization by the Selection Committee constituted as per norms of the University, your services shall terminated with effect from the date on which the candidate selected by the said committee reports for duty.

Yours faithfully,

**For Dr.D.Y.Patil Educational Enterprises Charitable Trust**

  
**Prof.B.G.Bhandarkar**  
**Director Corporate Relations**  
**Authorised Signatory**

Copy to

- 1 Principal/Director Dr.D.Y.Patil School of Engineering  
[ 2 copies  .Personal File 2.Accounts Section ]
- 2 Chief Financial Officer Head office
- 3 DYPEECT Master File



D Y PATIL GROUP

Dr D Y PATIL EDUCATIONAL ENTERPRISES CHARITABLE TRUST

Ref.ADYPKC/SOE/AO/T/AB//2020-21/ 37

Date: 10.08.2020

To,  
Ms. Ashwini Adeshkumar Bagade  
AA1, RL-136,  
G Block, MIDC,  
Shahunagar, Chinchwad, Pune.  
Email- [ashwini.sakar127@gmail.com](mailto:ashwini.sakar127@gmail.com)  
Contact- 8007165625

Appointment Order

Ms. Ashwini Adeshkumar Bagade,

Following your application and subsequent interview for the post of **Assistant Professor**, I am pleased to inform you that the Management has appointed you as **Assistant Professor in Electronics and Telecommunication Engineering Department at Dr. D Y Patil School of Engineering**. The terms & conditions of the appointment are as follows.

- 1) Your services are governed by the Maharashtra Universities Act, statues, ordinances, rules & regulations, code of conduct, laid down by the Savitribai Phule Pune University, Government of Maharashtra and service rules of the Trust and will be responsible to the Principal/Director of the Institute for discharge of your duties.
- 2) Your appointment is on **purely temporary basis** for a period of **Academic Year 2020-21 (i.e. upto 31<sup>st</sup> May 2021 only)** from the date of joining i.e.10<sup>th</sup> August 2020.
- 3) You will be paid consolidated monthly salary of **Rs. 35000 (Rs Thirty Five Thousand Only)**. No other allowances will be admissible. The salary payment will be subject to statutory deduction of taxes as applicable.
- 4) Your appointment is subject to the minimum numbers of the students and the sufficient workload prescribed for the post.
- 5) Your appointment is on purely temporary basis and will automatically come to an end on the expiry of tenure and in any such event; you shall not claim any right to be continued in the services. You shall not claim to be a regular/permanent employee of the Institute/College. At any time during the tenure of your services or after termination thereof, in any manner whatsoever, and shall not claim automatic re-appointment to the said post after expiry of the tenure of your services and you will not be eligible for any retiral benefits.
- 6) You shall submit the certified true copies of relevant documents such as birth certificate, mark sheets, experience certificates, Approval Letters, reliving certificate, Aadhar Card, PAN card, Last Pay Slip from the previous Employer before joining the duties.
- 7) You will produce 2 passport size recent photographs.
- 8) You are required to give the correct mailing address as soon as you join your duties. It will be presumed that any letter sent by Registered Post Acknowledgement Due (RPAD) or Speed Post or E-Mail on the address given, shall be deemed to have been acknowledged duly signed by you.
- 9) You are entitled Casual Leave as per Rules & Regulation of DYPEECT, subject to changes from time to time.
- 10) You are entitled for Medical Leave only after completion of one-year regular services and as per Rules & Regulation of DYPEECT, subject to changes from time to time.
- 11) If you want to leave the service during the tenure of your appointment, you will have to give one month's notice in writing to the Management. A sum equal to your one months' salary will be deducted or you will need to deposit the same amount to employer in case you resign without serving a one months' notice period. It is desirable that being a teaching faculty, you do not leave the job when the academic session is in progress.
- 12) You will submit to the office the medical fitness certificate from the Registered Medical panel appointed by the DYPEECT before joining your duties.

Page 1 of 2

- 13) You will not conduct or engage yourself in private tuitions or private coaching classes.
- 14) You will not engage yourself in any other paid job, full time, part time, honorary or otherwise during the continuance of your service in this Institute/College. You will not undertake any R & D or consultancy work and not register for any degree / diploma / certificate course without approval of the competent authority of the Trust.
- 15) You will not appear for any examinations/Admission without prior permission of the management in service.
- 16) You will not take any active part in the politics, neither involved directly or indirectly in illegal financial matters.
- 17) Your services are transferable within the trust organization only.
- 18) You will not directly or indirectly get yourself involved in any of the anti-activities against the management which may cause any harm to the institute/college or the management.
- 19) Your behavior with colleagues and entire institute/college staff should be polite, co-operative and gentle.
- 20) You will not form any union or organization amongst yourself and colleagues.
- 21) You will not process any letters either signed by you or signed jointly on any issues against the Management/Authorities without prior permission of the Principal/Director. Also, you will not approach to any authorities connected to the Institute/ College / Trust without prior permission of the Principal / Director.
- 22) You will put your grievances to the Management through Principal / Director only.
- 23) You will have to carry out the duties / work assigned to you by the Principal / Director and the Management besides your teaching work / routine work.
- 24) If you found absent continuously for more than 15 days without prior written permission from the Principal/Director, your services will stand terminated automatically and no further correspondence will be entertained thereafter.
- 25) Any information given in the application form if found incorrect contradictory at any time after the appointment, your services will be terminated forthwith, and no further correspondence will be entertained thereafter.
- 26) Progress Report: You will submit your academic progress report and other activities, seminars, presentation of papers, workshop, Self Appraisal etc. twice every year in the months of April and November.
- 27) If it is observed that your performance is not satisfactory / your behavior is not in the interest of the institute or College or trust / you commit breach of terms and conditions as mentioned in your appointment / you are found medically unfit (physically/mentally), your services shall be terminated without giving any notice period.
- 28) You will have to communicate your acceptance in writing to the Management/Director/Principal **within two weeks** from the date of receipt of Order of Appointment, failing which your appointment is liable to be withdrawal / cancelled. However, in case you need an extension of time limit for joining the duties you will have to apply in writing for grant of extension stating the reasons for the same and indicating the date on which you intend to join the duties. The request for grant of extension of time limit for joining the duties for the post shall be considered and you will be informed in the matter. The decision of the management of the **Dr. D Y Patil School of Engineering** shall be final.
- 29) If you are found guilty of violation of any terms & conditions mentioned above you will be liable for disciplinary action and punishment decided by the Management/Director/ Principal as provided in the Rules & Regulations.
- 30) In view of this appointment order, the previous appointment order/s stands cancelled.
- 31) Any dispute arises in the service will be dealt legally in jurisdiction of Pune City only.

For Dr. D Y Patil Educational Enterprises Charitable Trust

  
**Hrridaysh Deshpande**  
Authorized Signatory



**Copy to:**

- 1 Master File DYPEECT.
- 2 Principal, Dr. D Y Patil School of Engineering  
(Two Copies: [1] Personal File [2] Accounts Section).
- 3 Chief Financial Officer, DYPEECT.



## Dr D Y PATIL EDUCATIONAL ENTERPRISES CHARITABLE TRUST

Ref.ADYPKC/SOE/AO/T/SM//2020-21/36

Date: 14.08.2020

To,  
**Ms. Sayali Sanket Mane**  
257, Lane No.06,  
Khese Park,  
Lohegaon,  
Pune-411032  
Email- [sayalismane@gmail.com](mailto:sayalismane@gmail.com)  
Contact- 9730084266

### Appointment Order

**Ms. Sayali Sanket Mane,**

Following your application and subsequent interview for the post of **Assistant Professor**, I am pleased to inform you that the Management has appointed you as **Assistant Professor in Electronics and Telecommunication Engineering Department at Dr. D Y Patil School of Engineering**. The terms & conditions of the appointment are as follows.

- 1) Your services are governed by the Maharashtra Universities Act, statues, ordinances, rules & regulations, code of conduct, laid down by the Savitribai Phule Pune University, Government of Maharashtra and service rules of the Trust and will be responsible to the Principal/Director of the Institute for discharge of your duties.
- 2) Your appointment is on **purely temporary basis** for a period of **Academic Year 2020-21 (i.e. upto 31<sup>st</sup> May 2021 only)** from the date of joining i.e.14<sup>th</sup> August 2020.
- 3) You will be paid consolidated monthly salary of **Rs. 35000 Only (Rs Thirty Five Thousand Only)**. No other allowances will be admissible. The salary payment will be subject to statutory deduction of taxes as applicable.
- 4) Your appointment is subject to the minimum numbers of the students and the sufficient workload prescribed for the post.
- 5) Your appointment is on purely temporary basis and will automatically come to an end on the expiry of tenure and in any such event; you shall not claim any right to be continued in the services. You shall not claim to be a regular/permanent employee of the Institute/College. At any time during the tenure of your services or after termination thereof, in any manner whatsoever, and shall not claim automatic re-appointment to the said post after expiry of the tenure of your services and you will not be eligible for any retiral benefits.
- 6) You shall submit the certified true copies of relevant documents such as birth certificate, mark sheets, experience certificates, Approval Letters, reliving certificate, Aadhar Card, PAN card, Last Pay Slip from the previous Employer before joining the duties.
- 7) You will produce 2 passport size recent photographs.
- 8) You are required to give the correct mailing address as soon as you join your duties. It will be presumed that any letter sent by Registered Post Acknowledgement Due (RPAD) or Speed Post or E-Mail on the address given, shall be deemed to have been acknowledged duly signed by you.
- 9) You are entitled Casual Leave as per Rules & Regulation of DYPEECT, subject to changes from time to time.
- 10) You are entitled for Medical Leave only after completion of one-year regular services and as per Rules & Regulation of DYPEECT, subject to changes from time to time.
- 11) If you want to leave the service during the tenure of your appointment, you will have to give one month's notice in writing to the Management. A sum equal to your one months' salary will be deducted or you will need to deposit the same amount to employer in case you resign without serving a one months' notice period. It is desirable that being a teaching faculty, you do not leave the job when the academic session is in progress.
- 12) You will submit to the office the medical fitness certificate from the Registered Medical panel appointed by the DYPEECT before joining your duties.

Page 1 of 2

Received  
25/8/2020

- 13) You will not conduct or engage yourself in private tuitions or private coaching classes.
- 14) You will not engage yourself in any other paid job, full time, part time, honorary or otherwise during the continuance of your service in this Institute/College. You will not undertake any R & D or consultancy work and not register for any degree / diploma / certificate course without approval of the competent authority of the Trust.
- 15) You will not appear for any examinations/Admission without prior permission of the management in service.
- 16) You will not take any active part in the politics, neither involved directly or indirectly in illegal financial matters.
- 17) Your services are transferable within the trust organization only.
- 18) You will not directly or indirectly get yourself involved in any of the anti-activities against the management which may cause any harm to the institute/college or the management.
- 19) Your behavior with colleagues and entire institute/college staff should be polite, co-operative and gentle.
- 20) You will not form any union or organization amongst yourself and colleagues.
- 21) You will not process any letters either signed by you or signed jointly on any issues against the Management/Authorities without prior permission of the Principal/Director. Also, you will not approach to any authorities connected to the Institute/ College / Trust without prior permission of the Principal / Director.
- 22) You will put your grievances to the Management through Principal / Director only.
- 23) You will have to carry out the duties / work assigned to you by the Principal / Director and the Management besides your teaching work / routine work.
- 24) If you found absent continuously for more than 15 days without prior written permission from the Principal/Director, your services will stand terminated automatically and no further correspondence will be entertained thereafter.
- 25) Any information given in the application form if found incorrect contradictory at any time after the appointment, your services will be terminated forthwith, and no further correspondence will be entertained thereafter.
- 26) Progress Report: You will submit your academic progress report and other activities, seminars, presentation of papers, workshop, Self Appraisal etc. twice every year in the months of April and November.
- 27) If it is observed that your performance is not satisfactory / your behavior is not in the interest of the institute or College or trust / you commit breach of terms and conditions as mentioned in your appointment / you are found medically unfit (physically/mentally), your services shall be terminated without giving any notice period.
- 28) You will have to communicate your acceptance in writing to the Management/Director/Principal **within two weeks** from the date of receipt of Order of Appointment, failing which your appointment is liable to be withdrawal / cancelled. However, in case you need an extension of time limit for joining the duties you will have to apply in writing for grant of extension stating the reasons for the same and indicating the date on which you intend to join the duties. The request for grant of extension of time limit for joining the duties for the post shall be considered and you will be informed in the matter. The decision of the management of the **Dr. D Y Patil School of Engineering** shall be final.
- 29) If you are found guilty of violation of any terms & conditions mentioned above you will be liable for disciplinary action and punishment decided by the Management/Director/ Principal as provided in the Rules & Regulations.
- 30) In view of this appointment order, the previous appointment order/s stands cancelled.
- 31) Any dispute arises in the service will be dealt legally in jurisdiction of Pune City only.

*For Dr. D Y Patil Educational Enterprises Charitable Trust*

*Hrridaysh*

**Hrridaysh Deshpande**  
**Authorized Signatory**



**Copy to:**

- 1 Master File DYPEECT.
- 2 Principal, Dr. D Y Patil School of Engineering  
(Two Copies: [1] Personal File, [2] Accounts Section).
- 3 Chief Financial Officer, DYPEECT.



## Dr D Y PATIL EDUCATIONAL ENTERPRISES CHARITABLE TRUST

Ref.ADYPKC/SOE/AO/T/GT/2020-21/ 35

Date: 10.08.2020

To,  
Mr. Gaurav Tiwari  
Tiwari medical Store,  
Vill+Pos- Wallipur,  
Tal+Dist UP-227812  
Email- gauravshyamjitiwari@gmail.com  
Contact- 9765281946

### Appointment order

Mr. Gaurav Tiwari,

Following your application and subsequent interview for the post of **Assistant Professor**, I am pleased to inform you that the Management has appointed you as **Assistant Professor in Electronics and Telecommunication Engineering Department at Dr. D Y Patil School of Engineering**. The terms & conditions of the appointment are as follows.

- 1) Your services are governed by the Maharashtra Universities Act, statutes, ordinances, rules & regulations, code of conduct, laid down by the Savitribai Phule Pune University, Government of Maharashtra and service rules of the Trust and will be responsible to the Principal/Director of the Institute for discharge of your duties.
- 2) Your appointment is on **purely temporary basis** for a period of **Academic Year 2020-21 (i.e. upto 31<sup>st</sup> May 2021 only)** from the date of joining i.e. 10<sup>th</sup> August 2020.
- 3) You will be paid consolidated monthly salary of **Rs. 35000 Only (Rs Thirty Five Thousand Only)**. No other allowances will be admissible. The salary payment will be subject to statutory deduction of taxes as applicable.
- 4) Your appointment is subject to the minimum numbers of the students and the sufficient workload prescribed for the post.
- 5) Your appointment is on purely temporary basis and will automatically come to an end on the expiry of tenure and in any such event; you shall not claim any right to be continued in the services. You shall not claim to be a regular/permanent employee of the Institute/College. At any time during the tenure of your services or after termination thereof, in any manner whatsoever, and shall not claim automatic re-appointment to the said post after expiry of the tenure of your services and you will not be eligible for any retiral benefits.
- 6) You shall submit the certified true copies of relevant documents such as birth certificate, mark sheets, experience certificates, Approval Letters, relieving certificate, Aadhar Card, PAN card, Last Pay Slip from the previous Employer before joining the duties.
- 7) You will produce 2 passport size recent photographs.
- 8) You are required to give the correct mailing address as soon as you join your duties. It will be presumed that any letter sent by Registered Post Acknowledgement Due (RPAD) or Speed Post or E-Mail on the address given, shall be deemed to have been acknowledged duly signed by you.
- 9) You are entitled Casual Leave as per Rules & Regulation of DYPEECT, subject to changes from time to time.
- 10) You are entitled for Medical Leave only after completion of one-year regular services and as per Rules & Regulation of DYPEECT, subject to changes from time to time.
- 11) If you want to leave the service during the tenure of your appointment, you will have to give one month's notice in writing to the Management. A sum equal to your one months' salary will be deducted or you will need to deposit the same amount to employer in case you resign without serving a one months' notice period. It is desirable that being a teaching faculty, you do not leave the job when the academic session is in progress.
- 12) You will submit to the office the medical fitness certificate from the Registered Medical panel appointed by the DYPEECT before joining your duties.

Page 1 of 2

Received  
25/8/2020



- 13) You will not conduct or engage yourself in private tuitions or private coaching classes.
- 14) You will not engage yourself in any other paid job, full time, part time, honorary or otherwise during the continuance of your service in this Institute/College. You will not undertake any R & D or consultancy work and not register for any degree / diploma / certificate course without approval of the competent authority of the Trust.
- 15) You will not appear for any examinations/Admission without prior permission of the management in service.
- 16) You will not take any active part in the politics, neither involved directly or indirectly in illegal financial matters.
- 17) Your services are transferable within the trust organization only.
- 18) You will not directly or indirectly get yourself involved in any of the anti-activities against the management which may cause any harm to the institute/college or the management.
- 19) Your behavior with colleagues and entire institute/college staff should be polite, co-operative and gentle.
- 20) You will not form any union or organization amongst yourself and colleagues.
- 21) You will not process any letters either signed by you or signed jointly on any issues against the Management/Authorities without prior permission of the Principal/Director. Also, you will not approach to any authorities connected to the Institute/ College / Trust without prior permission of the Principal / Director.
- 22) You will put your grievances to the Management through Principal / Director only.
- 23) You will have to carry out the duties / work assigned to you by the Principal / Director and the Management besides your teaching work / routine work.
- 24) If you found absent continuously for more than 15 days without prior written permission from the Principal/Director, your services will stand terminated automatically and no further correspondence will be entertained thereafter.
- 25) Any information given in the application form if found incorrect contradictory at any time after the appointment, your services will be terminated forthwith, and no further correspondence will be entertained thereafter.
- 26) Progress Report: You will submit your academic progress report and other activities, seminars, presentation of papers, workshop, Self Appraisal etc. twice every year in the months of April and November.
- 27) If it is observed that your performance is not satisfactory / your behavior is not in the interest of the institute or College or trust / you commit breach of terms and conditions as mentioned in your appointment / you are found medically unfit (physically/mentally), your services shall be terminated without giving any notice period.
- 28) You will have to communicate your acceptance in writing to the Management/Director/Principal **within two weeks** from the date of receipt of Order of Appointment, failing which your appointment is liable to be withdrawal / cancelled. However, in case you need an extension of time limit for joining the duties you will have to apply in writing for grant of extension stating the reasons for the same and indicating the date on which you intend to join the duties. The request for grant of extension of time limit for joining the duties for the post shall be considered and you will be informed in the matter. The decision of the management of the **Dr. D Y Patil School of Engineering** shall be final.
- 29) If you are found guilty of violation of any terms & conditions mentioned above you will be liable for disciplinary action and punishment decided by the Management/Director/ Principal as provided in the Rules & Regulations.
- 30) In view of this appointment order, the previous appointment order/s stands cancelled.
- 31) Any dispute arises in the service will be dealt legally in jurisdiction of Pune City only.

*For Dr. D Y Patil Educational Enterprises Charitable Trust*

*Hridaysh*  
**Hridaysh Deshpande**  
**Authorized Signatory**



**Copy to:**

- 1 Master File DYPEECT.
- 2 Principal, Dr. D Y Patil School of Engineering  
(Two Copies: [1] Personal File, [2] Accounts Section).
- 3 Chief Financial Officer, DYPEECT.



## Dr D Y PATIL EDUCATIONAL ENTERPRISES CHARITABLE TRUST

Ref.ADYPKC/SOE/AO/T/YS/2020-21/ 34

Date: 10.08.2020

Mr.Yogesh Y. Shinde  
Yash Niwas Opp Hp Petrol Pump  
Kalewadi  
Alandi Depo  
Pune (MH)  
Email- [yogeshshinde8189@gmail.com](mailto:yogeshshinde8189@gmail.com)  
Contact- 7387059404

### Appointment Order

Mr. Yogesh Y. Shinde,

Following your application and subsequent interview for the post of **Assistant Professor**, I am pleased to inform you that the Management has appointed you as **Assistant Professor in Electronics and Telecommunication Engineering Department at Dr. D Y Patil School of Engineering**. The terms & conditions of the appointment are as follows.

- 1) Your services are governed by the Maharashtra Universities Act, statues, ordinances, rules & regulations, code of conduct, laid down by the Savitribai Phule Pune University, Government of Maharashtra and service rules of the Trust and will be responsible to the Principal/Director of the Institute for discharge of your duties.
- 2) Your appointment is on **purely temporary basis** for a period of **Academic Year 2020-21 (i.e. upto 31<sup>st</sup> May 2021 only)** from the date of joining i.e.10<sup>th</sup> August 2020.
- 3) You will be paid consolidated monthly salary of **Rs. 35000 Only (Rs Thirty Five Thousand Only)**. No other allowances will be admissible. The salary payment will be subject to statutory deduction of taxes as applicable.
- 4) Your appointment is subject to the minimum numbers of the students and the sufficient workload prescribed for the post.
- 5) Your appointment is on purely temporary basis and will automatically come to an end on the expiry of tenure and in any such event; you shall not claim any right to be continued in the services. You shall not claim to be a regular/permanent employee of the Institute/College. At any time during the tenure of your services or after termination thereof, in any manner whatsoever, and shall not claim automatic re-appointment to the said post after expiry of the tenure of your services and you will not be eligible for any retiral benefits.
- 6) You shall submit the certified true copies of relevant documents such as birth certificate, mark sheets, experience certificates, Approval Letters, reliving certificate, Aadhar Card, PAN card, Last Pay Slip from the previous Employer before joining the duties.
- 7) You will produce 2 passport size recent photographs.
- 8) You are required to give the correct mailing address as soon as you join your duties. It will be presumed that any letter sent by Registered Post Acknowledgement Due (RPAD) or Speed Post or E-Mail on the address given, shall be deemed to have been acknowledged duly signed by you.
- 9) You are entitled Casual Leave as per Rules & Regulation of DYPEECT, subject to changes from time to time.
- 10) You are entitled for Medical Leave only after completion of one-year regular services and as per Rules & Regulation of DYPEECT, subject to changes from time to time.
- 11) If you want to leave the service during the tenure of your appointment, you will have to give one month's notice in writing to the Management. A sum equal to your one months' salary will be deducted or you will need to deposit the same amount to employer in case you resign without serving a one months' notice period. It is desirable that being a teaching faculty, you do not leave the job when the academic session is in progress.
- 12) You will submit to the office the medical fitness certificate from the Registered Medical panel appointed by the DYPEECT before joining your duties.

Page 1 of 2

Received  
[Signature]  
29/08/2020

- 13) You will not conduct or engage yourself in private tuitions or private coaching classes.
- 14) You will not engage yourself in any other paid job, full time, part time, honorary or otherwise during the continuance of your service in this Institute/College. You will not undertake any R & D or consultancy work and not register for any degree / diploma / certificate course without approval of the competent authority of the Trust.
- 15) You will not appear for any examinations/Admission without prior permission of the management in service.
- 16) You will not take any active part in the politics, neither involved directly or indirectly in illegal financial matters.
- 17) Your services are transferable within the trust organization only.
- 18) You will not directly or indirectly get yourself involved in any of the anti-activities against the management which may cause any harm to the institute/college or the management.
- 19) Your behavior with colleagues and entire institute/college staff should be polite, co-operative and gentle.
- 20) You will not form any union or organization amongst yourself and colleagues.
- 21) You will not process any letters either signed by you or signed jointly on any issues against the Management/Authorities without prior permission of the Principal/Director. Also, you will not approach to any authorities connected to the Institute/ College / Trust without prior permission of the Principal / Director.
- 22) You will put your grievances to the Management through Principal / Director only.
- 23) You will have to carry out the duties / work assigned to you by the Principal / Director and the Management besides your teaching work / routine work.
- 24) If you found absent continuously for more than 15 days without prior written permission from the Principal/Director, your services will stand terminated automatically and no further correspondence will be entertained thereafter.
- 25) Any information given in the application form if found incorrect contradictory at any time after the appointment, your services will be terminated forthwith, and no further correspondence will be entertained thereafter.
- 26) Progress Report: You will submit your academic progress report and other activities, seminars, presentation of papers, workshop, Self Appraisal etc. twice every year in the months of April and November.
- 27) If it is observed that your performance is not satisfactory / your behavior is not in the interest of the institute or College or trust / you commit breach of terms and conditions as mentioned in your appointment / you are found medically unfit (physically/mentally), your services shall be terminated without giving any notice period.
- 28) You will have to communicate your acceptance in writing to the Management/Director/Principal **within two weeks** from the date of receipt of Order of Appointment, failing which your appointment is liable to be withdrawal / cancelled. However, in case you need an extension of time limit for joining the duties you will have to apply in writing for grant of extension stating the reasons for the same and indicating the date on which you intend to join the duties. The request for grant of extension of time limit for joining the duties for the post shall be considered and you will be informed in the matter. The decision of the management of the **Dr. D Y Patil School of Engineering** shall be final.
- 29) If you are found guilty of violation of any terms & conditions mentioned above you will be liable for disciplinary action and punishment decided by the Management/Director/ Principal as provided in the Rules & Regulations.
- 30) In view of this appointment order, the previous appointment order/s stands cancelled.
- 31) Any dispute arises in the service will be dealt legally in jurisdiction of Pune City only.

*For Dr. D Y Patil Educational Enterprises Charitable Trust*

*Hrridaysh*  
**Hrridaysh Deshpande**  
 Authorized Signatory



**Copy to:**

- 1 Master File DYPEECT.
- 2 Principal, Dr. D Y Patil School of Engineering  
(Two Copies: [1] Personal File [2] Accounts Section).
- 3 Chief Financial Officer, DYPEECT.



**Dr D Y PATIL EDUCATIONAL ENTERPRISES CHARITABLE TRUST**

Ref.ADYPKC/ITC/T/LSSC/2020-21/017/04

Date: 15.06.2020

To,  
Dr.Saniya Ansari  
C/o Ansari M.B RMC Garden,  
Phase-1, Flat No 02,  
Building 3/B,  
Wagholi,Pune  
Email- ansari.saniya6@gmail.com  
Contact- 9730478086

**Appointment Order**

**Dr.Saniya Ansari,**

Following your application and subsequent interview for the post of **Assistant Professor**, I am pleased to inform you that the Management has appointed you as **Associate Professor** in **E&TC Engineering Department** at **Dr. D Y Patil School of Engineering**. The terms & conditions of the appointment are as follows.

- 1) Your services are governed by the Maharashtra Universities Act, statues, ordinances, rules & regulations, code of conduct, laid down by the Savitribai Phule Pune University, Government of Maharashtra and service rules of the Trust and will be responsible to the Principal/Director of the Institute for discharge of your duties.
- 2) Your appointment is on **purely temporary basis** for a period of **Academic Year 2020-21 (i.e. upto 31<sup>st</sup> May 2021 only)** from the date of joining i.e. **15<sup>th</sup> June 2020**.
- 3) You will be paid consolidated monthly salary of **Rs. 75,000 (Rs Seventy-Five Thousand Only)**. No other allowances will be admissible. The salary payment will be subject to statutory deduction of taxes as applicable
- 4) Your appointment is subject to the minimum numbers of the students and the sufficient workload prescribed for the post.
- 5) Your appointment is on purely temporary basis and will automatically come to an end on the expiry of tenure and in any such event; you shall not claim any right to be continued in the services. You shall not claim to be a regular/permanent employee of the Institute/College. At any time during the tenure of your services or after termination thereof, in any manner whatsoever, and shall not claim automatic re-appointment to the said post after expiry of the tenure of your services and you will not be eligible for any retiral benefits.
- 6) You shall submit the certified true copies of relevant documents such as birth certificate, mark sheets, experience certificates, Approval Letters, reliving certificate, Aadhar Card, PAN card, Last Pay Slip from the previous Employer before joining the duties.
- 7) You will produce 2 passport size recent photographs.
- 8) You are required to give the correct mailing address as soon as you join your duties. It will be presumed that any letter sent by Registered Post Acknowledgement Due (RPAD) or Speed Post or E-Mail on the address given, shall be deemed to have been acknowledged duly signed by you.
- 9) You are entitled Casual Leave as per Rules & Regulation of DYPEECT, subject to changes from time to time.
- 10) You are entitled for Medical Leave only after completion of one-year regular services and as per Rules & Regulation of DYPEECT, subject to changes from time to time.
- 11) If you want to leave the service during the tenure of your appointment, you will have to give one month's notice in writing to the Management. A sum equal to your one months' salary will be deducted or you will need to deposit the same amount to employer in case you resign without serving a one months' notice period. It is desirable that being a teaching faculty, you do not leave the job when the academic session is in progress.
- 12) You will submit to the office the medical fitness certificate from the Registered Medical panel appointed by the DYPEECT before joining your duties.



*Saniya Ansari*  
*Reverend*

Page 1 of 2

- 13) You will not conduct or engage yourself in private tuitions or private coaching classes.
- 14) You will not engage yourself in any other paid job, full time, part time, honorary or otherwise during the continuance of your service in this Institute/College. You will not undertake any R & D or consultancy work and not register for any degree / diploma / certificate course without approval of the competent authority of the Trust.
- 15) You will not appear for any examinations/Admission without prior permission of the management in service.
- 16) You will not take any active part in the politics, neither involved directly or indirectly in illegal financial matters.
- 17) Your services are transferable within the trust organization only.
- 18) You will not directly or indirectly get yourself involved in any of the anti-activities against the management which may cause any harm to the institute/college or the management.
- 19) Your behavior with colleagues and entire institute/college staff should be polite, co-operative and gentle.
- 20) You will not form any union or organization amongst yourself and colleagues.
- 21) You will not process any letters either signed by you or signed jointly on any issues against the Management/Authorities without prior permission of the Principal/Director. Also, you will not approach to any authorities connected to the Institute/ College / Trust without prior permission of the Principal / Director.
- 22) You will put your grievances to the Management through Principal / Director only.
- 23) You will have to carry out the duties / work assigned to you by the Principal / Director and the Management besides your teaching work / routine work.
- 24) If you found absent continuously for more than 15 days without prior written permission from the Principal/Director, your services will stand terminated automatically and no further correspondence will be entertained thereafter.
- 25) Any information given in the application form if found incorrect contradictory at any time after the appointment, your services will be terminated forthwith, and no further correspondence will be entertained thereafter.
- 26) Progress Report: You will submit your academic progress report and other activities, seminars, presentation of papers, workshop, Self Appraisal etc. twice every year in the months of April and November.
- 27) If it is observed that your performance is not satisfactory / your behavior is not in the interest of the institute or College or trust / you commit breach of terms and conditions as mentioned in your appointment / you are found medically unfit (physically/mentally), your services shall be terminated without giving any notice period.
- 28) You will have to communicate your acceptance in writing to the Management/Director/Principal **within two weeks** from the date of receipt of Order of Appointment, failing which your appointment is liable to be withdrawal / cancelled. However, in case you need an extension of time limit for joining the duties you will have to apply in writing for grant of extension stating the reasons for the same and indicating the date on which you intend to join the duties. The request for grant of extension of time limit for joining the duties for the post shall be considered and you will be informed in the matter. The decision of the management of the **Dr. D Y Patil School of Engineering** shall be final.
- 29) If you are found guilty of violation of any terms & conditions mentioned above you will be liable for disciplinary action and punishment decided by the Management/Director/ Principal as provided in the Rules & Regulations.
- 30) In view of this appointment order, the previous appointment order/s stands cancelled.
- 31) Any dispute arises in the service will be dealt legally in jurisdiction of Pune City only.

*For Dr. D Y Patil Educational Enterprises Charitable Trust*

*Hrridaysh*  
**Hrridaysh Deshpande**  
**Authorized Signatory**



**Copy to:**

- 1 Master File DYPEECT.
- 2 Principal, Dr. D Y Patil School of Engineering  
(Two Copies: [1] Personal File [2] Accounts Section).
- 3 Chief Financial Officer, DYPEECT.



D Y PATIL GROUP

DR D Y PATIL GROUP OF INSTITUTION'S  
DR D Y PATIL TECHNICAL CAMPUS

## Dr D Y PATIL SCHOOL OF ENGINEERING

No.DrDYPSOE/KRS/22062015

Date: 22/06/2015

### APPOINTMENT ORDER

To:  
Mr Kundan R Saraf  
**E Mail:** kundansaraf@gmail.com  
**Mobile:** +91 9226967072

**Sub:** Appointment to the Post of Assistant Professor in Department of Electronics & Telecommunication Engineering at Dr D Y Patil School of Engineering, Pune

Sir,

With reference to the subject mentioned above, we have pleasure to inform you that you are appointed as **Assistant Professor in Department of Electronics & Telecommunication Engineering** at Dr D Y Patil School of Engineering at Dr D Y Patil Knowledge City, Charholi Bk., Via Lohegaon, Pune 412 105. This appointment is subject to the following terms and conditions:

- 1) The appointment will be effective from the date of your joining the duties.
- 2) The appointment is on temporary ad-hoc basis. You will have to apply and appear for interview before a Selection Committee constituted as per norms of Pune University as and when the posts are advertised, for regularization of your appointment. The continuation of your appointment is subject to your performance, recommendations and decision of this committee.
- 3) You will be paid a monthly remuneration which includes basic pay of Rs 17550 (Rs Seventeen Thousand Five Hundred and Fifty Only) plus Academic Grade Pay (AGP) of Rs. 6,000 (Rs Six Thousand) in Sixth Pay Commission Pay Band of Rs 15,600 - 39100 and other allowances as prescribed by the Trust from time to time. The salary payments will be subject to deduction of statutory taxes as applicable.
- 4) You will have to perform duties as mentioned below
  - a) To teach the subject/s assigned to you by the Principal/Director of the School (Theory as well as Practical) in accordance with the syllabus of the University.
  - b) To carry out any other duties as may be assigned to you from time to time by the Principal/Director of the School for smooth conduct of academic and allied co-curricular programmes and conduct of various institute and university examinations including assessment of papers.
  - c) To participate in various skill development /reorientation / training programmes aimed at upgrading teaching capabilities of teaching faculty.

- 5) For discharge of your duties you will be responsible to the Principal/ Director of the School of Engineering and subject the rules and regulations as laid down by the University, AICTE and State Government & Trust.
- 6) While joining the duties, you will have to submit two sets of certified true copies of documents in support of your qualifications, experience, discharge certificate from previous employer and three recent passport size photographs and execute an agreement as prescribed by the Trust.
- 7) You will be required to undergo medical examination before Medical Officer attached to the Dr D Y Patil Knowledge City Campus when medical check up of staff of the Institutions in the Dr D Y Patil Knowledge City Campus is organized.
- 8) You will have to submit your correct mailing address on joining the duties and also keep the Director of the School informed about subsequent changes, if there be any. The communication sent by the institute by RPAD on the address given by you shall be deemed to have been received and acknowledged by you.
- 9) You will not conduct or engage yourself in any private tuitions or private coaching classes., will not engage yourself in any other job, paid or honorary, full time or part time while in the service of the this institute.
- 10) Your services are transferable to any other institute run by D Y Patil Group.
- 11) You will have to give three months' notice or pay/forgo three month's salary in lieu of the notice period while resigning the job. It is desirable that being a teaching faculty, you do not leave the job when the teaching session is in progress.
- 12) a) If it is observed that your performance is not satisfactory /your behavior is not in the interest of the institute/trust/ you commit breach of the terms and conditions governing your appointment/you are found medically unfit (physically/mentally), your services shall be terminated without giving any notice period.  
b) Your continuous unauthorized absence from duty for more than fifteen days shall lead to automatic termination of your services from the date from which you remain absent.  
c) If you are not selected and recommended for regularization by the Selection Committee constituted as per norms of the University, your services shall terminated with effect from the date on which the candidate selected by the said committee reports for duty.

Yours faithfully,

**For Dr D Y Patil School of Engineering**



**Prof B G Bhandarkar**  
**Director Corporate Relations**  
**Authorised Signatory**

Copy to

1. Principal/Director Dr D Y Patil School of Engineering  
[2 copies 1. Personal File 2. Accounts Section]
2. Chief Financial Officer Head Office
3. DYPEECT Master File



D.Y. PATIL GROUP

## Dr.D.Y.PATIL EDUCATIONAL ENTERPRISES CHARITABLE TRUST

502, Blue Hills CHS, Pune-Nagar Road, Yeravada, Pune 411 006.

[ Mumbai Public Trust Registration No. E 4417 Pune : 11.10.2005 ]

No.DrDYPEECT/IC/APP/ 1057

Date : 31.7.2010

### D.Y.PATIL GROUP OF INSTITUTIONS APPOINTMENT ORDER

To:

**Ms.Rohini S.Gadgil Sastakar,  
Flat No.4, Building No.17 C,  
Vishrant CHS, Vishrantwadi,Alandi Road,  
Pune 411 015**

Sub : Appointment to the Post of **Assistant Professor of Electrical Engineering**  
at Dr.D.Y.Patil Integrated Campus, Pune

Sir/Madam,

With reference to the subject mentioned above, we have pleasure to inform you that you are appointed as **Assistant Professor of Electrical Engineering** at Dr.D.Y.Patil Integrated Campus [ Dr.D.Y.Patil School of Engineering ] at Dr.D.Y.Patil Knowledge City, Charholi Bk.,Via Lohegaon, Pune 412 105.This appointment is subject to the following terms and conditions :

- 1) The appointment will be effective from the date of your joining the duties, however not later than 16<sup>th</sup> August 2010.If you fail to join the duties by this date, the appointment order shall stand cancelled automatically ,unless extension for joining the duties is requested by you and granted by the Trust.
- 2) The appointment is on temporary ad-hoc basis .You will have to apply and appear for interview before a Selection Committee constituted as per norms of Pune University as and when the posts are advertised, for regularization of your appointment. The continuation of your appointment is subject to recommendations and decision of this committee.
- 3) You will be paid pay of Rs.33150/- (Rs.Thirty three thousand one hundred fifty only ) plus Academic Grade Pay (AGP) of Rs.6000/-(Rs,six thousand only ) per month in Sixth Pay Commission Pay Band of Rs.15600-39100 and other allowances as prescribed by Government of Maharashtra / AICTE from time to time.The salary payments will be subject to deduction of statutory taxes as applicable.
- 4) You will have to perform duties as mentioned below :
  - a) To teach the subject/s assigned to you by Head of Department/ Director of the Institute ( theory as well as practicals ) in accordance with the syllabus of the University .
  - b) To carry out any other duties as may be assigned to you from time to time by Head of Department/Head of Institute for smooth conduct of academic and allied co-curriculum programmes as well as conduct of various institute and university examinations.
  - c) To participate in various skill development /reorientation / training programmes aimed at upgrading teaching capabilities of teaching faculty.



- 5) For discharge of your duties you will be responsible to the Director of the Integrated Campus and subject to the rules and regulations as laid down by the University, AICTE and State Government.
- 6) While joining the duties, you will have to submit two sets of certified true copies of documents in support of your qualifications, experience, discharge certificate from previous employer and three recent passport size photographs.
- 7) You will be required to undergo medical examination before Medical Officer attached to the Integrated Campus when medical check up of staff of the Institutions under Integrated Campus is organized.
- 8) You will have to submit your correct mailing address on joining the duties and also keep the Director of the institute informed about subsequent changes, if there be any. The communication sent by the institute by RPAD on the address given by you shall be deemed to have been received and acknowledged by you.
- 9) You will not conduct or engage yourself in any private tuitions or private coaching classes., will not engage yourself in any other job, paid or honorary, full time or part time while in the service of the this institute.
- 10) Your services are transferable to any other institute run by D.Y.Patil Group.
- 11) While joining the duties you will have give an undertaking that you have read and understood the terms and conditions governing your appointment and that you will abide by them.
- 12) You will have to give one month's notice or pay/forgo one month's salary in lieu of the notice period while resigning the job. It is desirable that being a teaching faculty, you do not leave the job when the teaching session is in progress.
- 13) a) If it is observed that your performance is not satisfactory /your behaviour is not in the interest of the institute/trust/ you commit breach of the terms and conditions governing your appointment/you are found medically unfit (physically/mentally) ,your services shall be terminated without giving any notice period.  
b) Your continuous unauthorized absence from duty for more than fifteen days shall lead to automatic termination of your services from the date from which you remain absent.  
c) If you are not selected and recommended for regularization by the Selection Committee constituted as per norms of the University, your services shall terminated with effect from the date on which the candidate selected by the said committee reports for duty.
- 14) You will have to convey your acceptance within 10 days from the date of this appointment order by E mail on E Mail Id dypeect@gmail.com, failing which the appointment order is liable to be cancelled.

Yours faithfully,

**For Dr.D.Y.Patil Educational Enterprises Charitable Trust**

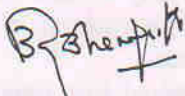

**Prof.B.G.Bhandarkar**  
**Director Corporate Relations**  
**Authorised Signatory**

Copy to

- 1 Director Dr.D.Y.Patil Group of Institutions :Integrated Campus ,  
[ 2 copies ✓.Personal File 2.Accounts Section ]
- 2 Chief Financial Officer Head office
- 3 DYPEECT Master File



D Y PATIL GROUP

**Dr D Y PATIL EDUCATIONAL ENTERPRISES CHARITABLE TRUST**

No.DrDYPEECT/IC/APP/SoE/15-022

Date : 16.2.2015

**APPOINTMENT ORDER**

To:

**Mr. Tirupati Solanke**

E Mail : tirupati\_11@rediffmail.com

Mobile : +91 72767 27008

**Sub : Appointment to the Post of Asstt Prof of Electronics & Telecommunications Engineering at Dr.D.Y.Patil School of Engineering Pune**

Sir ,

With reference to the subject mentioned above, we have pleasure to inform you that you are appointed as **Asstt. Professor of Electronics & Telecommunication Engineering** at Dr.D.Y.Patil School of Engineering at Dr.D.Y.Patil Knowledge City, Charholi Bk., Via Lohegaon, Pune 412 105. This appointment is subject to the following terms and conditions :

- 1) The appointment will be effective from the date of your joining the duties .
- 2) The appointment is on temporary ad-hoc basis .You will have to apply and appear for interview before a Selection Committee constituted as per norms of Pune University as and when the posts are advertised, for regularization of your appointment. The continuation of your appointment is subject to your performance , recommendations and decision of this committee.
- 3) You will be paid basic pay of Rs 17,550/- ( Rs. Seventeen thousand & five hundred fifty only ) plus Academic Grade Pay (AGP) of Rs. 6000/- ( Rs. Six thousand only ) per month in Sixth Pay Commission Pay Band of Rs.15600-39100 and other allowances as prescribed by the Trust from time to time. In addition to this you will be entitled to personal pay of Rs.4000/- (Rs.Four thousand only ) per month which will be suitably adjusted in the event of increase in DA. The salary payments will be subject to deduction of statutory taxes as applicable.
- 4) You will have to perform duties as mentioned below
  - a) To teach the subject/s assigned to you by the Principal/Director of the School (Theory as well as Practicals ) in accordance with the syllabus of the University.
  - b) To carry out any other duties as may be assigned to you from time to time by the Principal/Director of the School for smooth conduct of academic and allied co-curricular programmes and conduct of various institute and university examinations including assessment of papers.
  - c) To participate in various skill development /reorientation / training programmes aimed at upgrading teaching capabilities of teaching faculty.
- 5) For discharge of your duties you will be responsible to the Principal/ Director of the School of Engineering and subject the rules and regulations as laid down by the University, AICTE and State Government & Trust .
- 6) While joining the duties, you will have to submit two sets of certified true copies of documents in support of your qualifications , experience, discharge certificate from previous employer and three recent passport size photographs and execute an agreement as prescribed by the Trust..

Received  
Tirupati  
27/2/15

J  
24/02/15

- 7) You will be required to undergo medical examination before Medical Officer attached to the .Dr.D.Y.Patil Knowledge City Campus when medical check up of staff of the Institutions in the Dr.D.Y.Patil Knowledge City Campus is organized .
- 8) You will have to submit your correct mailing address on joining he duties and also keep the Director of the School informed about subsequent changes, if there be any. The communication sent by the institute by RPAD on the address given by you shall be deemed to have been received and acknowledged by you.
- 9) You will not conduct or engage yourself in any private tuitions or private coaching classes., will not engage yourself in any other job, paid or honorary, full time or part time while in the service of the this institute.
- 10) Your services are transferable to any other institute run by D.Y.Patil Group.
- 11) You will have to give one month's notice or pay/forgo one month's salary in lieu of the notice period while resigning the job.It is desirable that being a teaching faculty , you do not leave the job when the teaching session is in progress.
- 12) a) If it is observed that your performance is not satisfactory /your behaviour is not in the interest of the institute/trust/ you commit breach of the terms and conditions governing your appointment/you are found medically unfit (physically/mentally) ,your services shall be terminated without giving any notice period.  
b) Your continuous unauthorized absence from duty for more than fifteen days shall lead to automatic termination of your services from the date from which you remain absent.  
c) If you are not selected and recommended for regularization by the Selection Committee constituted as per norms of the University, your services shall terminated with effect from the date on which the candidate selected by the said committee reports for duty.

Yours faithfully,

**For Dr.D.Y.Patil Educational Enterprises Charitable Trust**

  
**Prof.B.G.Bhandarkar**  
**Director Corporate Relations**  
**Authorised Signatory**

Copy to

- ✓ 1 Principal/Director Dr.D.Y.Patil School of Engineering  
[ 2 copies ✓.Personal File 2.Accounts Section ]
- 2 Chief Administrative Officer
- 3 DYPEECT Master File



D.Y. PATIL GROUP

## Dr.D.Y.PATIL EDUCATIONAL ENTERPRISES CHARITABLE TRUST

502, Blue Hills CHS, Pune-Nagar Road, Yeravada, Pune 411 006.

[ Mumbai Public Trust Registration No. E 4417 Pune : 11.10.2005 ]

No.DrDYPEECT/IC/APP/ 1058

Date: 31.7.2010

### D.Y.PATIL GROUP OF INSTITUTIONS APPOINTMENT ORDER

To:

**Ms.Soma Cyriac,  
A 37, Mont Vert, Phase II,  
Pashan-Sus Road, Pune 411 021**

Sub : Appointment to the Post of **Assistant Professor of Applied Physics**  
at Dr.D.Y.Patil Integrated Campus, Pune

Sir/Madam,

With reference to the subject mentioned above, we have pleasure to inform you that you are appointed as **Assistant Professor of Applied Physics** at Dr.D.Y.Patil Integrated Campus [ Dr.D.Y.Patil School of Engineering ] at Dr.D.Y.Patil Knowledge City, Charholi Bk., Via Lohegaon, Pune 412 105. This appointment is subject to the following terms and conditions :

- 1) The appointment will be effective from the date of your joining the duties, however not later than 16<sup>th</sup> August 2010. If you fail to join the duties by this date, the appointment order shall stand cancelled automatically, unless extension for joining the duties is requested by you and granted by the Trust.
- 2) The appointment is on temporary ad-hoc basis. You will have to apply and appear for interview before a Selection Committee constituted as per norms of Pune University as and when the posts are advertised, for regularization of your appointment. The continuation of your appointment is subject to recommendations and decision of this committee.
- 3) You will be paid pay of Rs.34450/- (Rs.Thirty four thousand four hundred fifty only ) plus Academic Grade Pay (AGP) of Rs.6000/- (Rs,six thousand only ) per month in Sixth Pay Commission Pay Band of Rs.15600-39100 and other allowances as prescribed by Government of Maharashtra / AICTE from time to time. The salary payments will be subject to deduction of statutory taxes as applicable.
- 4) You will have to perform duties as mentioned below :
  - a) To teach the subject/s assigned to you by Head of Department/Director of the Institute (theory as well as practicals ) in accordance with the syllabus of the University
  - b) To carry out any other duties as may be assigned to you from time to time by Head of Department/Head of Institute for smooth conduct of academic and allied co-curriculum programmes as well as conduct of various institute and university examinations.
  - c) To participate in various skill development /reorientation / training programmes aimed at upgrading teaching capabilities of teaching faculty.

- 5) For discharge of your duties you will be responsible to the Director of the Integrated Campus and subject to the rules and regulations as laid down by the University, AICTE and State Government.
- 6) While joining the duties, you will have to submit two sets of certified true copies of documents in support of your qualifications, experience, discharge certificate from previous employer and three recent passport size photographs.
- 7) You will be required to undergo medical examination before Medical Officer attached to the Integrated Campus when medical check up of staff of the Institutions under Integrated Campus is organized.
- 8) You will have to submit your correct mailing address on joining the duties and also keep the Director of the institute informed about subsequent changes, if there be any. The communication sent by the institute by RPAD on the address given by you shall be deemed to have been received and acknowledged by you.
- 9) You will not conduct or engage yourself in any private tuitions or private coaching classes., will not engage yourself in any other job, paid or honorary, full time or part time while in the service of the this institute.
- 10) Your services are transferable to any other institute run by D.Y.Patil Group.
- 11) While joining the duties you will have give an undertaking that you have read and understood the terms and conditions governing your appointment and that you will abide by them.
- 12) You will have to give one month's notice or pay/forgo one month's salary in lieu of the notice period while resigning the job. It is desirable that being a teaching faculty, you do not leave the job when the teaching session is in progress.
- 13) a) If it is observed that your performance is not satisfactory /your behaviour is not in the interest of the institute/trust/ you commit breach of the terms and conditions governing your appointment/you are found medically unfit (physically/mentally) ,your services shall be terminated without giving any notice period.  
b) Your continuous unauthorized absence from duty for more than fifteen days shall lead to automatic termination of your services from the date from which you remain absent.  
c) If you are not selected and recommended for regularization by the Selection Committee constituted as per norms of the University, your services shall terminated with effect from the date on which the candidate selected by the said committee reports for duty.
- 14) You will have to convey your acceptance within 10 days from the date of this appointment order by E mail on E Mail Id dypeect@gmail.com, failing which the appointment order is liable to be cancelled.

Yours faithfully,

**For Dr.D.Y.Patil Educational Enterprises Charitable Trust**

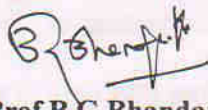

**Prof.B.G.Bhandarkar**  
**Director Corporate Relations**  
**Authorised Signatory**

Copy to

- 1 Director Dr.D.Y.Patil Group of Institutions :Integrated Campus ,  
[ 2 copies ✓ 1. Personal File 2.Accounts Section ]
- 2 Chief Financial Officer Head office
- 3 DYPEECT Master File



**D Y PATIL GROUP**

**Dr D Y PATIL EDUCATIONAL ENTERPRISES CHARITABLE TRUST**

No.DrDYPEECT/SoE/US/APP/ 12- 219

Date: 26.12.2012

**D.Y PATIL GROUP OF INSTITUTIONS  
APPOINTMENT ORDER**

To

**Mr. Niraj Kumar Jadhav**

Assistant Professor, - Applied Chemistry

Dr. D.Y.Patil. School Of Engineering

Charholi (Bk), Lohegaon, Pune.

**Subject: Appointment letter for the Post of Assistant Professor at Dr. D.Y Patil School of Engineering, Charholi (Bk), Lohegaon, Pune.**

With reference of your application of post of Assistant Professor in Applied Chemistry in response to advertisement on 8/8/2012 Subsequent interview on 30/11/2012. We have pleasure to informing you that you are appointed as **Assistant Professor** at Dr. D. Y. Patil School of Engineering, Dr. D. Y Patil Knowledge City Charholi (Bk), Via Lohegaon, Pune - 412105. Appointment is subject to the following terms & conditions:

1. This appointment is effective from **01/12/2012**
2. You will be governed by the Maharashtra universities Act 1994, Statues, Code of conduct, ordinances, rules and regulations laid down by the University of Pune, State government and service rules of Trust and will be responsible to Head of the institute for discharge of your duties.
3. The post is reserved for **Open** category and since you belong to **Open** category you are appointed in clear vacancy on fulltime, you will be on probation for a period of two years, subject to approval by University of Pune. The continuation beyond probation period will be subject to your satisfactory completion of probation.
4. You will be paid basic salary of Rs. 15600/- (Rs Fifteen Thousand and Six Hundred only) plus Academic Grade Pay of Rs. 6000/- (Rs. Six Thousand Only) in the pay scale of 15600-39100.
5. You will have to perform duties as mentioned below :
  - a. To teach the subject/s assigned to you by the Head of Department/ Institute (theory as well as practical) in accordance with syllabus of Pune University.
  - b. To carry out any other as may be assigned to you from time to time by the Head of Department / Institute for smooth conduct of academic and allied co-curricular activities as well as conduct of various institute level and university.
  - c. To participate in various skill development/reorientation/training programmes

*Qudlow*  
27/12/12

6. You shall undergo medical examination by the approval Medical Officer attached with Dr. D. Y. Patil Knowledge City within three month from the date of joining the duties the appointments shall be provisional and conditional, pending submission of Medical Certificate stating that you are free from any contagious disease and you are physically and mentally fit for employment as the staff of the college.
7. You will not engage yourself in any private tuitions or private coaching classes, will not engage yourself in any of the job, paid or honorary, full time or part time, while in the service of the institute. You will not undertake any R & D or Consultancy work and not register for any degree/diploma/certificate course without of the competent authority of the Trust.
8. You will submit your correct mailing address while joining the duties and also inform in writing to Head of the institute about subsequent changes, if there be any .The communication sent by RPAD on the address given by you shall be deemed to have been received by you.
9. You will have to give one month notice or pay/forgo one month's salary in lieu of notice period while resigning the job. It is desirable that being a teaching faculty, you do not leave the job when the academic session is in process.
10.
  - a. If it is observed that you performance is not satisfactory/your behavior is not interest of the institute /trust/you committ breach of terms and conditions governing you appointment /you are found medically unfit (Physically/mentally), your service shall be terminated without giving any notice period
  - b. Your continuous unauthorized absences from duty for more than fifteen days shall lead to automatic termination of your services from the date you remain absent from duties.
  - c. In view of this appointment order, the pervious order stands cancelled
  - d. While joining the duties you will have to give an undertaking that you have read and understood the terms & condition governing your appointment and you will abide by them.

Yours faithfully,  
For Dr. D Y Patil Educational Enterprises Charitable Trust.

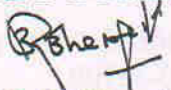
  
Prof. B. G. Bhandarkar  
Director Corporate Relations  
Authorized Signatory

Copy to: 1. Director Dr. D Y Patil School of Engineering  
(2 Copies 1. Personal File 2. Accounts Section)  
2. Head Accounts and Finance.

Received  
  
27/12/12

  
27/12/2012



DR D Y PATIL GROUP

DR D Y PATIL GROUP OF INSTITUTION'S  
DR D Y PATIL TECHNICAL CAMPUS

## Dr D Y PATIL SCHOOL OF ENGINEERING

No. DrDYPSOE/AL/TCP/01122014

Date : 01/12/2014

### APPOINTMENT ORDER

To:

Mr. Tirupati Solanke

E Mail: tirupati\_11@rediffmail.com

Mobile: +91 7276727008

Sub: Appointment to the Post of Assistant Professor, Electronics & Telecommunication Engineering Department at Dr D Y Patil School of Engineering, Pune

Sir,

With reference to the subject mentioned above, we have pleasure to inform you that you are appointed as **Assistant Professor, Electronics & Telecommunication Engineering Department** at Dr D Y Patil School of Engineering at Dr D Y Patil Knowledge City, Charholi Bk., Via Lohegaon, Pune 412 105. This appointment is subject to the following terms and conditions :

- 1) The appointment will be effective from the date of your joining the duties.
- 2) The appointment is on temporary ad-hoc basis. You will have to apply and appear for interview before a Selection Committee constituted as per norms of Pune University as and when the posts are advertised, for regularization of your appointment. The continuation of your appointment is subject to your performance, recommendations and decision of this committee.
- 3) You will be paid basic pay of Rs 17,550 (Rs Seventeen Thousand Five Hundred and Fifty only) per month plus special pay of Rs 4000 (Rs Four Thousand) per month and other allowances as prescribed by the Trust from time to time. The special pay to be adjusted in the event of increase of DA. The salary payments will be subject to deduction of statutory taxes as applicable.
- 4) You will have to perform duties as mentioned below

*29/12/15 Prof. Tirupati Solanke*

*Rec  
Gmpati  
1/12/14*



- a) To teach the subject/s assigned to you by the Principal/Director of the School (Theory as well as Practical) in accordance with the syllabus of the University.
  - b) To carry out any other duties as may be assigned to you from time to time by the Principal/Director of the School for smooth conduct of academic and allied co-curricular programmes and conduct of various institute and university examinations including assessment of papers.
  - c) To participate in various skill development /reorientation / training programmes aimed at upgrading teaching capabilities of teaching faculty.
- 5) For discharge of your duties you will be responsible to the Principal/ Director of the School of Engineering and subject the rules and regulations as laid down by the University, AICTE and State Government & Trust.
  - 6) While joining the duties, you will have to submit two sets of certified true copies of documents in support of your qualifications, experience, discharge certificate from previous employer and three recent passport size photographs and execute an agreement as prescribed by the Trust.
  - 7) You will be required to undergo medical examination before Medical Officer attached to the Dr D Y Patil Knowledge City Campus when medical check up of staff of the Institutions in the Dr.D.Y.Patil Knowledge City Campus is organized.
  - 8) You will have to submit your correct mailing address on joining the duties and also keep the Director of the School informed about subsequent changes, if there be any. The communication sent by the institute by RPAD on the address given by you shall be deemed to have been received and acknowledged by you.
  - 9) You will not conduct or engage yourself in any private tuitions or private coaching classes., will not engage yourself in any other job, paid or honorary, full time or part time while in the service of the this institute.
  - 10) Your services are transferable to any other institute run by D Y Patil Group.
  - 11) You will have to give three month's notice or pay/forgo three month's salary in lieu of the notice period while resigning the job. It is desirable that being a teaching faculty, you do not leave the job when the teaching session is in progress.
  - 12) a) If it is observed that your performance is not satisfactory /your behavior is not in the interest of the institute/trust/ you commit breach of the terms and conditions governing your appointment/you are found medically unfit (physically/mentally) ,your services shall be terminated without giving any notice period.  
b) Your continuous unauthorized absence from duty for more than fifteen days shall lead to automatic termination of your services from the date from which you remain absent.

- c) If you are not selected and recommended for regularization by the Selection Committee constituted as per norms of the University, your services shall terminated with effect from the date on which the candidate selected by the said committee reports for duty.

Yours faithfully,

**For Dr D Y Patil School of Engineering**

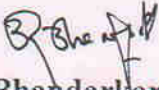

**Prof. B. G. Bhandarkar**  
**Director Corporate Relations**  
**Authorised Signatory**

Copy to

- 1 Principal/Director Dr.D.Y.Patil School of Engineering  
[2 copies 1 .Personal File 2.Accounts Section]
- 2 Chief Financial Officer Head Office
- 3 DYPEECT Master File



**Dr D Y PATIL EDUCATIONAL ENTERPRISES CHARITABLE TRUST**

No.DrDYPEECT /DYPSOE/US/APP/2017/586-55

Date: 29.03.2017

**APPOINTMENT ORDER**

To,  
Dr S. M. Khairnar  
Sanjay park, Pune .

**Subject:** Appointment to the Post of **Professor** at **Dr. D Y Patil School of Engineering.**

Sir,

With reference to your application for the post of **Professor** in **Dr. D Y Patil School of Engineering**, in response to advertisement on 6<sup>th</sup> Februarys, 2017 in Indian Express and Loksatta and subsequent interview on 26<sup>th</sup> March, 2017 before Selection Committee constituted by Savitribai Phule Pune University. We have pleasure in informing you that you are selected by the committee and appointed as **Professor** at Dr. D Y Patil School of Engineering, Dr. D. Y. Patil Knowledge City, Charholi Bk, Via Lohegaon, Pune 412 105. The Appointment is subject to the following terms & conditions;

1. This appointment is effective from the date of your joining the duties. You will have to join the duties within **15 days** from the date of this appointment order *i.e.* **by 15<sup>th</sup> May, 2017**. In the event you do not join the duties within this time limit it will be assumed that you do not intend to join the duties and the appointment order issued in your favour will stand automatically cancelled on **15<sup>th</sup> May, 2017**.

However in case you need an extension of time limit for joining the duties you will have to apply in writing for grant of extension stating the reasons for the same and indicating the date on which you intend to join the duties. The request for grant of extension of time limit for joining the duties of the post shall be considered and you will be informed in the matter. The decision of the management of the Dr. D Y Patil School of Management shall be final.

2. You will be governed by the Maharashtra Universities Act , statues, ordinances, rules & regulations , code of conduct, laid down by the Savitribai Phule Pune University, Government of Maharashtra and service rules of the Trust and will be responsible to the Director of the Institute for discharge of your duties.

3. The post is for **Open** category and since you belong to **Open** category you are appointed in clear vacancy on fulltime basis and you will be on probation for a period of two years from the date of joining the duties subject to approval by Savitribai Phule Pune University. The continuation beyond probation period will be subject to your satisfactory completion of probation.

4. You will be paid basic salary of **Rs. 58900/-** (in words Rs. Fifty Eight Thousand Nine Hundred Only) plus Academic Grade Pay of **Rs. 10,000/-** (Rs. Ten Thousand Only) per month in the pay scale of **Rs. 37400-67000**.plus personal pay **Rs. 35275/-** (Rs. Thirty Five Thousand Two Seventy Five Only)

The Salary payment will be subject to deduction of statutory taxes as applicable.

*Postelash*  
*125517*

[PTO]

*Received*  
*24/5/2017*

*Kemp*

5. You will have to perform duties as mentioned below:

- a) To teach the subject/s assigned to you by the Head of Department/ Institute (theory as well as practicals) in accordance with syllabus of the Savitribai Phule Pune University.
- b) To carry out any other duties as may be assigned to you from time to time by the Head of Department / Institute for smooth conduct of academic and allied co-curricular activities as well as conduct of various institute level and university examinations.
- c) To participate in various skill development / reorientation / training programmes.

6. You shall undergo medical examination before Medical Officer attached with Dr. D Y Patil Knowledge City within three months from the date of joining the duties. The appointment shall be provisional and conditional, pending submission of Medical Certificate stating that you are free from any contagious disease and you are physically fit for employment as the staff of the Institute.

7. You will not engage yourself in any private tuitions or private coaching classes, will not engage yourself in any other job, paid or honorary, full time or part time, while in the service of the institute . You will not undertake any R & D or consultancy work and not register for any degree / diploma / certificate course without approval of the competent authority of the Trust.

8. While joining the duties you will have to submit a) Last Pay Slip from the previous Employer b) Two recent pass-post size photographs c) Two copies of the certificates in support of your qualifications & experience.

9. You will have to submit your correct mailing address while joining the duties and also inform in writing to the Head of the Institute about subsequent changes, if there be any. The communication sent by RPAD on the address given by you shall be deemed to have been received by you.

10. You will have to give one months notice or pay / forgo one month's salary in lieu of notice period while resigning the job. It is desirable that being a teaching faculty, you do not leave the job when the academic session is in progress.

11. a) If it is observed that your performance is not satisfactory / your behavior is not in the interest of the institute / trust / you commit breach of terms and conditions governing your appointment / you are found medically unfit (physically/mentally), your services shall be terminated without giving any notice period.

b) Your continuous unauthorized absence from duty for more than **fifteen days** shall lead to automatic termination of your services from the date you remain absent from duties.

**c) In view of this appointment order, the previous order stands cancelled.**

d) While joining the duties you will have to give an undertaking that you have read and understood the terms & conditions governing your appointment and that you will abide by them.

Yours faithfully,

*For Dr. D. Y. Patil Educational Enterprises Charitable Trust*

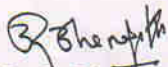

**(Prof. B. G. Bhandarkar)**  
**Secretary, DYPEECT.**  
Authorized Signatory

**Copy to:**

1. Director, Dr. D Y Patil School of Engineering  
(2 copies - 1. Personal File 2. Accounts Section)
2. Chief Administrative Officer 3. Chief Financial Officer.



**D Y PATIL GROUP**

**Dr D Y PATIL EDUCATIONAL ENTERPRISES CHARITABLE TRUST**

Ref.ADYPKC/SOE/AO/T/BG/2020-21/38

Date: 01.09.2020

To,  
Mr. Bhagwat Gidhad,  
A/P Kelewadi,  
Tal- Rahata,  
Dist- Ahmednagar-423107  
Email- [gidhaddb@gmail.com](mailto:gidhaddb@gmail.com)  
Contact- 9156963912

**Appointment Order**

**Mr. Bhagwat Gidhad,**

Following your application and subsequent interview for the post of **Assistant Professor-Mathematics**, I am pleased to inform you that the Management has appointed you as **Assistant Professor in Engineering Science Department at Dr. D Y Patil School of Engineering**. The terms & conditions of the appointment are as follows.

- 1) Your services are governed by the Maharashtra Universities Act, statues, ordinances, rules & regulations, code of conduct, laid down by the Savitribai Phule Pune University, Government of Maharashtra and service rules of the Trust and will be responsible to the Principal/Director of the Institute for discharge of your duties.
- 2) Your appointment is on **purely temporary basis** for a period of **Academic Year 2020-21 (i.e. upto 31<sup>st</sup> May 2021 only)** from the date of joining i.e. 01<sup>st</sup> September 2020.
- 3) You will be paid consolidated monthly salary of **Rs. 35,650 only (Rs Thirty Five Thousand Six Hundred Fifty Only)**. No other allowances will be admissible. The salary payment will be subject to statutory deduction of taxes as applicable.
- 4) Your appointment is subject to the minimum numbers of the students and the sufficient workload prescribed for the post.
- 5) Your appointment is on purely temporary basis and will automatically come to an end on the expiry of tenure and in any such event; you shall not claim any right to be continued in the services. You shall not claim to be a regular/permanent employee of the Institute/College. At any time during the tenure of your services or after termination thereof, in any manner whatsoever, and shall not claim automatic re-appointment to the said post after expiry of the tenure of your services and you will not be eligible for any retiral benefits.
- 6) You shall submit the certified true copies of relevant documents such as birth certificate, mark sheets, experience certificates, Approval Letters, reliving certificate, Aadhar Card, PAN card, Last Pay Slip from the previous Employer before joining the duties.
- 7) You will produce 2 passport size recent photographs.
- 8) You are required to give the correct mailing address as soon as you join your duties. It will be presumed that any letter sent by Registered Post Acknowledgement Due (RPAD) or Speed Post or E-Mail on the address given, shall be deemed to have been acknowledged duly signed by you.
- 9) You are entitled Casual Leave as per Rules & Regulation of DYPEECT, subject to changes from time to time.
- 10) You are entitled for Medical Leave only after completion of one-year regular services and as per Rules & Regulation of DYPEECT, subject to changes from time to time.
- 11) If you want to leave the service during the tenure of your appointment, you will have to give one month's notice in writing to the Management. A sum equal to your one months' salary will be deducted or you will need to deposit the same amount to employer in case you resign without serving a one months' notice period. It is desirable that being a teaching faculty, you do not leave the job when the academic session is in progress.
- 12) You will submit to the office the medical fitness certificate from the Registered Medical panel appointed by the DYPEECT before joining your duties.

Page 1 of 2

*Bhagwat*  
22/9/2020  
Due to joined on  
2/9/2020

- 13) You will not conduct or engage yourself in private tuitions or private coaching classes.
- 14) You will not engage yourself in any other paid job, full time, part time, honorary or otherwise during the continuance of your service in this Institute/College. You will not undertake any R & D or consultancy work and not register for any degree / diploma / certificate course without approval of the competent authority of the Trust.
- 15) You will not appear for any examinations/Admission without prior permission of the management in service.
- 16) You will not take any active part in the politics, neither involved directly or indirectly in illegal financial matters.
- 17) Your services are transferable within the trust organization only.
- 18) You will not directly or indirectly get yourself involved in any of the anti-activities against the management which may cause any harm to the institute/college or the management.
- 19) Your behavior with colleagues and entire institute/college staff should be polite, co-operative and gentle.
- 20) You will not form any union or organization amongst yourself and colleagues.
- 21) You will not process any letters either signed by you or signed jointly on any issues against the Management/Authorities without prior permission of the Principal/Director. Also, you will not approach to any authorities connected to the Institute/ College / Trust without prior permission of the Principal / Director.
- 22) You will put your grievances to the Management through Principal / Director only.
- 23) You will have to carry out the duties / work assigned to you by the Principal / Director and the Management besides your teaching work / routine work.
- 24) If you found absent continuously for more than 15 days without prior written permission from the Principal/Director, your services will stand terminated automatically and no further correspondence will be entertained thereafter.
- 25) Any information given in the application form if found incorrect contradictory at any time after the appointment, your services will be terminated forthwith, and no further correspondence will be entertained thereafter.
- 26) Progress Report: You will submit your academic progress report and other activities, seminars, presentation of papers, workshop, Self Appraisal etc. twice every year in the months of April and November.
- 27) If it is observed that your performance is not satisfactory / your behavior is not in the interest of the institute or College or trust / you commit breach of terms and conditions as mentioned in your appointment / you are found medically unfit (physically/mentally), your services shall be terminated without giving any notice period.
- 28) You will have to communicate your acceptance in writing to the Management/Director/Principal **within two weeks** from the date of receipt of Order of Appointment, failing which your appointment is liable to be withdrawal / cancelled. However, in case you need an extension of time limit for joining the duties you will have to apply in writing for grant of extension stating the reasons for the same and indicating the date on which you intend to join the duties. The request for grant of extension of time limit for joining the duties for the post shall be considered and you will be informed in the matter. The decision of the management of the **Dr. D Y Patil School of Engineering** shall be final.
- 29) If you are found guilty of violation of any terms & conditions mentioned above you will be liable for disciplinary action and punishment decided by the Management/Director/ Principal as provided in the Rules & Regulations.
- 30) In view of this appointment order, the previous appointment order/s stands cancelled.
- 31) Any dispute arises in the service will be dealt legally in jurisdiction of Pune City only.

*For Dr. D Y Patil Educational Enterprises Charitable Trust*

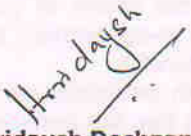
  
**Hrridaysh Deshpande**  
**Authorized Signatory**



**Copy to:**

- 1 Master File DYPEECT.
- 2 Principal, Dr. D Y Patil School of Engineering  
(Two Copies: [1] Personal File [2] Accounts Section).
- 3 Chief Financial Officer, DYPEECT.



**D Y PATIL GROUP**

**Dr D Y PATIL EDUCATIONAL ENTERPRISES CHARITABLE TRUST**

Ref. ADYPKC/SOE/AO/T/AU/2020-21/ 39

Date: 24.08.2020

To,  
Mr. Amit Uphad  
At post Ner  
Tq Dist Jalna  
Email- [amituphad143@gmail.com](mailto:amituphad143@gmail.com)  
Contact- 7798902221

**Appointment Order**

**Mr. Amit Uphad,**

Following your application and subsequent interview for the post of **Assistant Professor-Physics**, I am pleased to inform you that the Management has appointed you as **Assistant Professor in Engineering Science Department at Dr. D Y Patil School of Engineering**. The terms & conditions of the appointment are as follows.

- 1) Your services are governed by the Maharashtra Universities Act, statues, ordinances, rules & regulations, code of conduct, laid down by the Savitribai Phule Pune University, Government of Maharashtra and service rules of the Trust and will be responsible to the Principal/Director of the Institute for discharge of your duties.
- 2) Your appointment is on **purely temporary basis** for a period of **Academic Year 2020-21 (i.e. upto 31<sup>st</sup> May 2021 only)** from the date of joining i.e. 24<sup>th</sup> August 2020.
- 3) You will be paid consolidated monthly salary of **Rs. 35,000 only (Rs Thirty five Thousand Only)**. No other allowances will be admissible. The salary payment will be subject to statutory deduction of taxes as applicable.
- 4) Your appointment is subject to the minimum numbers of the students and the sufficient workload prescribed for the post.
- 5) Your appointment is on purely temporary basis and will automatically come to an end on the expiry of tenure and in any such event; you shall not claim any right to be continued in the services. You shall not claim to be a regular/permanent employee of the Institute/College. At any time during the tenure of your services or after termination thereof, in any manner whatsoever, and shall not claim automatic re-appointment to the said post after expiry of the tenure of your services and you will not be eligible for any retiral benefits.
- 6) You shall submit the certified true copies of relevant documents such as birth certificate, mark sheets, experience certificates, Approval Letters, reliving certificate, Aadhar Card, PAN card, Last Pay Slip from the previous Employer before joining the duties.
- 7) You will produce 2 passport size recent photographs.
- 8) You are required to give the correct mailing address as soon as you join your duties. It will be presumed that any letter sent by Registered Post Acknowledgement Due (RPAD) or Speed Post or E-Mail on the address given, shall be deemed to have been acknowledged duly signed by you.
- 9) You are entitled Casual Leave as per Rules & Regulation of DYPEECT, subject to changes from time to time.
- 10) You are entitled for Medical Leave only after completion of one-year regular services and as per Rules & Regulation of DYPEECT, subject to changes from time to time.
- 11) If you want to leave the service during the tenure of your appointment, you will have to give one month's notice in writing to the Management. A sum equal to your one months' salary will be deducted or you will need to deposit the same amount to employer in case you resign without serving a one months' notice period. It is desirable that being a teaching faculty, you do not leave the job when the academic session is in progress.
- 12) You will submit to the office the medical fitness certificate from the Registered Medical panel appointed by the DYPEECT before joining your duties.

Page 1 of 2

*for*  
*Received*  
*26/08/2020*

- 13) You will not conduct or engage yourself in private tuitions or private coaching classes.
- 14) You will not engage yourself in any other paid job, full time, part time, honorary or otherwise during the continuance of your service in this Institute/College. You will not undertake any R & D or consultancy work and not register for any degree / diploma / certificate course without approval of the competent authority of the Trust.
- 15) You will not appear for any examinations/Admission without prior permission of the management in service.
- 16) You will not take any active part in the politics, neither involved directly or indirectly in illegal financial matters.
- 17) Your services are transferable within the trust organization only.
- 18) You will not directly or indirectly get yourself involved in any of the anti-activities against the management which may cause any harm to the institute/college or the management.
- 19) Your behavior with colleagues and entire institute/college staff should be polite, co-operative and gentle.
- 20) You will not form any union or organization amongst yourself and colleagues.
- 21) You will not process any letters either signed by you or signed jointly on any issues against the Management/Authorities without prior permission of the Principal/Director. Also, you will not approach to any authorities connected to the Institute/ College / Trust without prior permission of the Principal / Director.
- 22) You will put your grievances to the Management through Principal / Director only.
- 23) You will have to carry out the duties / work assigned to you by the Principal / Director and the Management besides your teaching work / routine work.
- 24) If you found absent continuously for more than 15 days without prior written permission from the Principal/Director, your services will stand terminated automatically and no further correspondence will be entertained thereafter.
- 25) Any information given in the application form if found incorrect contradictory at any time after the appointment, your services will be terminated forthwith, and no further correspondence will be entertained thereafter.
- 26) Progress Report: You will submit your academic progress report and other activities, seminars, presentation of papers, workshop, Self Appraisal etc. twice every year in the months of April and November.
- 27) If it is observed that your performance is not satisfactory / your behavior is not in the interest of the institute or College or trust / you commit breach of terms and conditions as mentioned in your appointment / you are found medically unfit (physically/mentally), your services shall be terminated without giving any notice period.
- 28) You will have to communicate your acceptance in writing to the Management/Director/Principal **within two weeks** from the date of receipt of Order of Appointment, failing which your appointment is liable to be withdrawal / cancelled. However, in case you need an extension of time limit for joining the duties you will have to apply in writing for grant of extension stating the reasons for the same and indicating the date on which you intend to join the duties. The request for grant of extension of time limit for joining the duties for the post shall be considered and you will be informed in the matter. The decision of the management of the **Dr. D Y Patil School of Engineering** shall be final.
- 29) If you are found guilty of violation of any terms & conditions mentioned above you will be liable for disciplinary action and punishment decided by the Management/Director/ Principal as provided in the Rules & Regulations.
- 30) In view of this appointment order, the previous appointment order/s stands cancelled.
- 31) Any dispute arises in the service will be dealt legally in jurisdiction of Pune City only.

*For Dr. D Y Patil Educational Enterprises Charitable Trust*

*Hrridaysh*  
**Hrridaysh Deshpande**  
**Authorized Signatory**



**Copy to:**

- 1 Master File DYPEECT.
- 2 Principal, Dr. D Y Patil School of Engineering  
(Two Copies: [1] Personal File [2] Accounts Section).
- 3 Chief Financial Officer, DYPEECT.





**D Y PATIL GROUP**

**Dr D Y PATIL EDUCATIONAL ENTERPRISES CHARITABLE TRUST**

Ref.ADYPKC/SOE/AO/T/RK/2020-21/ 40

Date: 10.08.2020

To,  
**Dr.Rahul Kumar D Katkade**  
Sai Colony, B/H Man-Dhan,  
Fulari Mala,  
Savadi,  
Ahmednagar-414003  
Email- rkdtkatka@gmail.com  
Contact- 7755907799

**Appointment Order**

**Dr.Rahul Kumar D Katkade,**

Following your application and subsequent interview for the post of **Assistant Professor-Mathematics**, I am pleased to inform you that the Management has appointed you as **Assistant Professor in Engineering Science Department at Dr. D Y Patil School of Engineering**. The terms & conditions of the appointment are as follows.

- 1) Your services are governed by the Maharashtra Universities Act, statues, ordinances, rules & regulations, code of conduct, laid down by the Savitribai Phule Pune University, Government of Maharashtra and service rules of the Trust and will be responsible to the Principal/Director of the Institute for discharge of your duties.
- 2) Your appointment is on **purely temporary basis** for a period of **Academic Year 2020-21 (i.e. upto 31<sup>st</sup> May 2021 only)** from the date of joining i.e.10<sup>th</sup> August 2020.
- 3) You will be paid consolidated monthly salary of **Rs. 35,000 only (Rs Thirty five Thousand Only)**. No other allowances will be admissible. The salary payment will be subject to statutory deduction of taxes as applicable.
- 4) Your appointment is subject to the minimum numbers of the students and the sufficient workload prescribed for the post.
- 5) Your appointment is on purely temporary basis and will automatically come to an end on the expiry of tenure and in any such event; you shall not claim any right to be continued in the services. You shall not claim to be a regular/permanent employee of the Institute/College. At any time during the tenure of your services or after termination thereof, in any manner whatsoever, and shall not claim automatic re-appointment to the said post after expiry of the tenure of your services and you will not be eligible for any retiral benefits.
- 6) You shall submit the certified true copies of relevant documents such as birth certificate, mark sheets, experience certificates, Approval Letters, reliving certificate, Aadhar Card, PAN card, Last Pay Slip from the previous Employer before joining the duties.
- 7) You will produce 2 passport size recent photographs.
- 8) You are required to give the correct mailing address as soon as you join your duties. It will be presumed that any letter sent by Registered Post Acknowledgement Due (RPAD) or Speed Post or E-Mail on the address given, shall be deemed to have been acknowledged duly signed by you.
- 9) You are entitled Casual Leave as per Rules & Regulation of DYPEECT, subject to changes from time to time.
- 10) You are entitled for Medical Leave only after completion of one-year regular services and as per Rules & Regulation of DYPEECT, subject to changes from time to time.
- 11) If you want to leave the service during the tenure of your appointment, you will have to give one month's notice in writing to the Management. A sum equal to your one months' salary will be deducted or you will need to deposit the same amount to employer in case you resign without serving a one months' notice period. It is desirable that being a teaching faculty, you do not leave the job when the academic session is in progress.
- 12) You will submit to the office the medical fitness certificate from the Registered Medical panel appointed by the DYPEECT before joining your duties.

Page 1 of 2

Received by /  
25/08/2020

- 13) You will not conduct or engage yourself in private tuitions or private coaching classes.
- 14) You will not engage yourself in any other paid job, full time, part time, honorary or otherwise during the continuance of your service in this Institute/College. You will not undertake any R & D or consultancy work and not register for any degree / diploma / certificate course without approval of the competent authority of the Trust.
- 15) You will not appear for any examinations/Admission without prior permission of the management in service.
- 16) You will not take any active part in the politics, neither involved directly or indirectly in illegal financial matters.
- 17) Your services are transferable within the trust organization only.
- 18) You will not directly or indirectly get yourself involved in any of the anti-activities against the management which may cause any harm to the institute/college or the management.
- 19) Your behavior with colleagues and entire institute/college staff should be polite, co-operative and gentle.
- 20) You will not form any union or organization amongst yourself and colleagues.
- 21) You will not process any letters either signed by you or signed jointly on any issues against the Management/Authorities without prior permission of the Principal/Director. Also, you will not approach to any authorities connected to the Institute/ College / Trust without prior permission of the Principal / Director.
- 22) You will put your grievances to the Management through Principal / Director only.
- 23) You will have to carry out the duties / work assigned to you by the Principal / Director and the Management besides your teaching work / routine work.
- 24) If you found absent continuously for more than 15 days without prior written permission from the Principal/Director, your services will stand terminated automatically and no further correspondence will be entertained thereafter.
- 25) Any information given in the application form if found incorrect contradictory at any time after the appointment, your services will be terminated forthwith, and no further correspondence will be entertained thereafter.
- 26) Progress Report: You will submit your academic progress report and other activities, seminars, presentation of papers, workshop, Self Appraisal etc. twice every year in the months of April and November.
- 27) If it is observed that your performance is not satisfactory / your behavior is not in the interest of the institute or College or trust / you commit breach of terms and conditions as mentioned in your appointment / you are found medically unfit (physically/mentally), your services shall be terminated without giving any notice period.
- 28) You will have to communicate your acceptance in writing to the Management/Director/Principal **within two weeks** from the date of receipt of Order of Appointment, failing which your appointment is liable to be withdrawal / cancelled. However, in case you need an extension of time limit for joining the duties you will have to apply in writing for grant of extension stating the reasons for the same and indicating the date on which you intend to join the duties. The request for grant of extension of time limit for joining the duties for the post shall be considered and you will be informed in the matter. The decision of the management of the **Dr. D Y Patil School of Engineering** shall be final.
- 29) If you are found guilty of violation of any terms & conditions mentioned above you will be liable for disciplinary action and punishment decided by the Management/Director/ Principal as provided in the Rules & Regulations.
- 30) In view of this appointment order, the previous appointment order/s stands cancelled.
- 31) Any dispute arises in the service will be dealt legally in jurisdiction of Pune City only.

For Dr. D Y Patil Educational Enterprises Charitable Trust

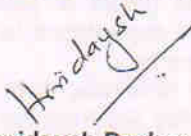
  
**Hridaysh Deshpande**  
**Authorized Signatory**



**Copy to:**

- 1 Master File DYPECT.
- 2 Principal, Dr. D Y Patil School of Engineering  
(Two Copies: [1] Personal File [2] Accounts Section).
- 3 Chief Financial Officer, DYPECT.



"Empowerment through quality technical education"  
Dr D Y Patil Educational Enterprises Charitable Trust's

**Ajeenkya D Y Patil Group of Institution's Technical Campus**  
**Dr D Y PATIL SCHOOL OF ENGINEERING**

(Approved by AICTE, New Delhi Recognized by Govt. of Maharashtra, Affiliated to Savitribai Phule Pune University)  
AISHE Code: C-46648 DTE Code: EN6732 SPPU PUN Code: CEGP015720  
**(Accredited by NAAC)**

**A.Y. 2020-21**

**Copy of PAN Cards of Teachers**

(Criteria 2.4.1)

<b>Program Name</b>	<b>Number of Teachers</b>
First Year Engg.	08 (01 copy is not available)
Civil Engg.	13
Computer Engg.	23
Mechanical Engg.	34
E&TC Engg	13
<b>Total</b>	<b>91</b> (01 copy is not available)

**Dr. F. B. Sayyad**





**Principal**

Enclosed: Copy of PAN Cards of Teachers.

## Dr. D Y Patil School of Engineering

Branch wise Staff List AY-2020-21

PAN Card Copy





Sr. No	Name of the Full-time teacher	PAN	Designation	PAN Card Copy
1.	Dr. S. M. Khairnar	AGQPK1277K	Professor & HOD	
2.	Prof. Rohini Gadgil	BFOPS0517J	Assistant Professor	
3.	Dr. Shobha Vasant Rupnar	ARPPR1012F	Assistant Professor	
4.	Prof. Niraj Jadhav	AVSPJ9767G	Assistant Professor	
5.	Prof. Soma Cyriac	ATCPC6831D	Assistant Professor	Not Available



# Dr. D Y Patil School of Engineering

Branch wise Staff List AY-2020-21

PAN Card Copy







Sr. No	Name of the Full-time teacher	PAN	Designation	PAN Card Copy
1	Dr. S. M. Khairnar	AGQPK1277K	Professor & HOD	
2	Prof. Rohini Gadgil	BFOP50517J	Assistant Professor	
3	Dr. Shobha Vasant Rupnar	ARPPR1012F	Assistant Professor	
4	Prof. Niraj Jadhav	AVSPJ9767G	Assistant Professor	
5	Prof. Soma Cyriac	AICPC6831D	Assistant Professor	Not Available





6	Dr.Rahul Kumar D Kattkade	CEVPK1676P	Assistant Professor	
7	Prof. Amit Uphad	AIYPU7777J	Assistant Professor	
8	Prof. Bhagwat Gidhad	CEZPG6333M	Assistant Professor	
9	Prof. Tirupati U Solanke	DKKPS2464F	Assistant Professor	
10	Lt.col. Sanjay Karodpati	ABXPK0188R	Assistant Professor	
11	Prof. Rajesh Kaldare	ACMPK9817F	Assistant Professor	
12	Prof. Ramakant Koshtri	AYNPK7736N	Assistant Professor	









13.	Prof. Swapnil Bijwe	FBGPS0962H	Assistant Professor	
14.	Prof. Uday A. Kakde	BKWPK7830F	Assistant Professor	
15.	Prof. Aakanksha Arun Ingle	AEDPI5052F	Assistant Professor	
16.	Prof. Pragya Sharma	GOSPS7201F	Assistant Professor	
17.	Prof. Uzma Shaikh	GOGPS6550F	Assistant Professor	
18.	Prof. Prasad Rangnath Gayake	BKKPG4681G	Assistant Professor	
19.	Prof. Aniket Vilas Nemade	AMQPN2843N	Assistant Professor	









20	Prof. Ahinsak B Taksande	BARPT6892B	Assistant Professor	
21	Prof. Jitendra Dattatray Dalvi	AENPD7780F	Assistant Professor	











22	Prof. Aradhana Ganvir	ARTPG4847K	Assistant Professor	
23	Dr. Pankaj Agarkar	AEKPA6791G	Assistant Professor	
24	Dr. Sunil Rathod	BPCPR1778C	Assistant Professor	
25	Prof. Pallavi Shirpi	DFYP59955C	Assistant Professor	
26	Prof. Jayashree Chaudhari	AQIPK3377I	Assistant Professor	
27	Prof. Amruta Chitani	AKBPA4100E	Assistant Professor	
28	Prof. Vandana Chavan	AJCPC7271Q	Assistant Professor	









29	Prof. Yogesh Mali	BZOPM5652C	Assistant Professor	
30	Prof. Chaitanya Bhosale	BBTPB6252L	Assistant Professor	
31	Prof. Ashwini Pandagale	BKCPP5467M	Assistant Professor	
32	Prof. Monika Yograj Dengore	BBOPD3099L	Assistant Professor	
33	Prof. Prashant Prabhakar Saqare	CVKPS4325R	Assistant Professor	
34	Prof. Vishal Kisan Borate	ARKPB6037F	Assistant Professor	
35	Prof. Faraz Aarif Bagwan	CBTPB4731M	Assistant Professor	









36	Prof. Prashant L. Mandale	CLKPM4975M	Assistant Professor	
37	Prof. Nilesh Mali	AOOPM7312P	Assistant Professor	
38	Prof. Niyamat Irfan Ujloomiwale	ACIPU1531D	Assistant Professor	
39	Prof. Pooja Dinker Shinde	EXNPS9534K	Assistant Professor	
40	Prof. Ajita Arvind Mahapadi	BZIPM7067D	Assistant Professor	
41	Prof. Manali Shimpi	DLJPS1412R	Assistant Professor	
42	Prof. Divyarani P Babar	BZVPB6502K	Assistant Professor	







43	Prof. Rutuja G. Rokade	CCHPR2349A	Assistant Professor	
44	Prof. Rekha S. Kotwal	CFEPK2795F	Assistant Professor	
45	Prof. Girisha Ramhari Bombale	AYKPB3636K	Assistant Professor	
46	Dr. Farook Bashir Sayyad	AYNPS9126L	Professor	
47	Prof. Rohit Nagesh Garad	ALIPG6426H	Assistant Professor	
48	Prof. Amol Baburao Gaikwad	BANPG1908B	Assistant Professor	
49	Prof. Sachin S. Jadhav	APRPJ7007G	Assistant Professor	









50	Prof.Yogesh S. Gandal	AQDPG1399P	Assistant Professor	
51	Dr. Dileep S. More	ATJPM2263P	Assistant Professor	
52	Prof.Prashant Gurushantappa Karajagi	AOXPK1159B	Assistant Professor	
53	Prof. Santosh Baburao Jadhav	AFCPJ9153L	Assistant Professor	
54	Prof. Amol Nanaji Patil	AXPPP3384G	Assistant Professor	
55	Prof.Yogesh Shankarrao Danekar	APOPD5502P	Assistant Professor	
56	Prof.Ghule Vikram M.	ARXPG0889M	Assistant Professor	









57	Prof.Parag Babu Marathe	AYHPM503ZF	Assistant Professor	
58	Prof.Jagruti C. Nimgulkar	AKXPN2356B	Assistant Professor	
59	Prof.Tejaswini Suhas Kulkarni	DNXPK3146J	Assistant Professor	
60	Prof. Paresh Pravin Khairnar	DAHPK3946K	Assistant Professor	
61	Pooja Nawathe	BFVFN3688C	Assistant Professor	
62	Prof. Umaji Kolekar	CORPK1961H	Assistant Professor	
63	Prof. Vinod Gopal Patil	BYOPP9441B	Assistant Professor	









64	Prof. Sandeep Bhaskar	AIJWP81943M	Assistant Professor	
65	Dr. Mohd. Imran Ansari	ANAPA1673Q	Assistant Professor	
66	Prof. Nitin More	BBOPM6487K	Assistant Professor	
67	Prof. Vinod Deoraaji Tirpude	ADJPT1707G	Assistant Professor	
68	Prof. Kunal Shriramprakash Marathe	BGFPM2678J	Assistant Professor	
69	Prof. Dipak D. Shelke	DDRPS6298M	Assistant Professor	
70	Prof. Amit Shinde	DEUPS5415A	Assistant Professor	









71	Prof. Awes Ansari	ARKPAS553F	Assistant Professor	
72	Prof. Anil Bavache	CGIPB1141D	Assistant Professor	
73	Prof. Kundan Suresh Kolambe	DPMPK7220A	Assistant Professor	
74	Prof. Rajabhau Housalmal	AEAPH9760G	Assistant Professor	
75	Prof. Avinash, R. Kulkarni	AMBPK7578C	Assistant Professor	
76	Prof. Santosh R. Thorat	ALRPT2853L	Assistant Professor	
77	Prof. Mayun Sanjay Mhaske	BKWPM3206R	Assistant Professor	





78	Prof. Meghasham Jagadish Joshi	AKOPJ7912N	Assistant Professor	
79	Prof. Himani Kadam	ALKPK5188L	Assistant Professor	
80	Dr. Sanjay Koli	ALSPK7778A	HOD & Professor	
81	Dr. Rashmi Mahajan	AMHPP2562P	Assistant Professor	
82	Prof. Riyaj L. Kazi	ARVPK8357J	Assistant Professor	
83	Dr. Bahubali Shirgarpur	BGNPS5767E	Assistant Professor	
84	Prof. Kundankumar Saraf	CPYPS1104N	Assistant Professor	



85	Prof. Swati Khawate	BMMPK6304E	Assistant Professor	
86	Prof. Nishikant B Surwade	CEBPS6783M	Assistant Professor	
87	Prof. Prajakta Khairnar	AWAPG7877P	Assistant Professor	
88	Dr. Saniya Ansari	AJQPG2834D	Associate Professor	
89	Prof. Gaurav Tiwari	ASLPT2103Q	Assistant Professor	
90	Prof. Sayali Sanket Manie	CDCPM8976J	Assistant Professor	
91	Prof. Ashwini Adeshkumar Bagade	ESVPS4216P	Assistant Professor	



92	Prof. Yogesh Y. Shinde	BNIPS2444G	Assistant Professor	
----	------------------------	------------	---------------------	---



*Dr. D. Y. Patil*

**Principal**  
Dr. D. Y. Patil School of Engineering  
Lohegaon, Pune.



17001247

Savitribai Phule Pune University  
(formerly University of Pune)

Telephone Nos. :  
020-25691233  
25601257  
25601258  
25601259



ACADEMIC SECTION  
Ganeshkhind, Pune-411 007,  
INDIA  
Telegraph : 'UNIPUNE'  
Fax: 020-25691233  
Website : www.unipune.ac.in  
Email : approval@unipune.ac.in

Ref.No. CC0/2258

Date: 10/11/17







To,

The Principal/Director,  
Dr. D.Y. Patil School of Engineering  
Dr. D.Y. Patil School of Engineering  
Addr: Dr. D.Y. Patil Knowledge city, Charol  
Bk, Via Lohegaon Pune -412105  
Ta: Pimpri Chinchwad (corporation Area)  
Dist: Pune

Subject : Approval to the Appointment of Teachers...

Sir/Madam

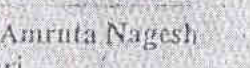
With reference to the Selection Committee report of teacher submitted by the college authorities to the Academic Section of the University and your subsequent letter No. DYPTC/SOE/2016-17/154, Dated : 23/08/2016 regarding the proposal for seeking teacher approval, I am directed to inform you that the appointment of following teachers are hereby approved with following particular:-

Sr.No	Name of the teacher	Post	Subject	Date and period of approval
1	Shri. Soumitra Sibsankar Das  170500233	Assistant Professor (Full Time)	Computer Engineering	W.e.f 29.03.2017
2	Shri. Pankaj M Agarkar  170500234	Assistant Professor (Full Time)	Computer Engineering	W.e.f 29.03.2017
3	Shri. Sunil Damodar Rathod  170500235	Assistant Professor (Full Time)	Computer Engineering	W.e.f 29.03.2017
4	Smt. Jayashree Lalit Chaudhari  170500236	Assistant Professor (Full Time)	Computer Engineering	W.e.f 29.03.2017
5	Smt. Amruta Nagesh Chitari  170500237	Assistant Professor (Full Time)	Computer Engineering	W.e.f 29.03.2017
6	Smt. Ashwini Govind Sagade  170500238	Assistant Professor (Full Time)	Computer Engineering	W.e.f 29.03.2017





170500237

7. Shri. Vaibhav Bhagwan  
Kate



170500230

Assistant Professor  
(Full Time)

Computer Engineering

W.e.f 29.03.2017

8

Smt. Pallavi Madhukarrao  
Shimpi



170500240

Assistant Professor  
(Full Time)

Computer Engineering

W.e.f 29.03.2017

9

Shri. Yogesh Anil Thorat



170500241

Assistant Professor  
(Full Time)

Computer Engineering

W.e.f 29.03.2017

At

The above said approval is issued on the basis of the certificate issued by the college authorities regarding fulfillment of all prescribed eligibility criteria, such as qualifications, experience (if essential), etc. by the candidate's before calling them for interview and the recommendations made by the Selection Committee to the University for according approval to the appointment of candidate's recommended by it.

If any suggestion / correction in the content of this approval letter, then please notify the same in writing within a period of three months from the date of issuance of this letter to the undersigned. No communication will be entertained thereafter.

In the event of any information or document submitted by the college authorities being found false or incorrect at any stage, an appropriate action will be initiated against the college authorities and the candidate concerned.

Yours Sincerely

  
for Deputy Registrar  
(Academic Section)



Dr. D. Y. Patil Technical Campus

# **Dr. D. Y. Patil School of Engineering**

Dr. D. Y. Patil Knowledge City, Charholi (Bk), Lohegaon, Pune – 412 105

## **4. CIE**

**(Continuous Internal  
Evaluation)**



**Dr. D. Y. Patil Technical Campus**  
**Dr. D. Y. Patil School of Engineering**  
 Dr. D. Y. Patil Knowledge City, Chhatkoti (Bk), Lohangraon, Pune - 412 105  
 Department of Computer Engineering  
 TE Computer Div. A & B Sem - I, AY 2020-21  
 TW Mark Assessment Sheet

Roll No.	PRN NO.	ERP No/ Application No	Students Name	DBMSL (TW 25 Marks)					CNL (TW 25 Marks)					SDL (TW 50 Marks)				
				UT-I	UT-II	UT-III	Att./ Assgn	Total (25)	UT-I	UT-II	UT-III	Att./ Assgn	Total (25)	UT-I	UT-II	UT-III	Att./ Assgn	Total (50)
1	71920021M	EN18157726	SIDDHANT ADASKAR	4	3	4	9	20	4	4	4	8	20	7	8	7	18	40
2	71920024D	EN18127458	ANIRUDH MHASKE	4	4	5	8	21	4	4	5	8	21	9	8	9	18	44
3	71920038F	EN18195233	ASHWINI PATIL	4	4	4	9	21	5	5	4	9	23	9	9	8	18	44
4	71920058L	EN18148257	ANKUSH BHANDARI	4	4	5	10	23	4	4	4	9	21	8	8	8	20	44
5	71920067K	EN18115097	CHANDANI KUMARI	4	5	5	10	24	4	5	5	10	24	8	8	8	20	44
6	71920069F	EN18132011	ABHISHEK CHATTAR	4	4	0	10	18	3	3	4	9	19	8	8	8	20	44
7	71920071H	EN18214036	KAUSTUBH CHAUDHARI	4	4	5	8	21	4	4	4	8	20	8	9	9	18	44
8	71920079C	EN18161727	ANKITA CHAVHAN	3	3	5	9	20	4	4	4	8	20	9	9	8	18	44
9	71920056D	EN18263250	DEVAKSH BHAGAT	3	3	5	10	21	4	5	4	9	22	8	8	8	20	44
10	71920101C	EN18120303	FIZA AZAM	4	5	5	10	24	5	5	4	9	23	8	8	8	20	44
11	71920102M	EN18166433	KARAN GADALE	4	4	4	9	21	4	4	5	9	22	8	8	8	20	44
12	71920105F	EN18116364	SAMARTH GARKVAD	4	3	4	7	18	3	3	4	7	17	7	7	8	12	34
13	71920106D	EN18169490	SIDDHESH GARKVAD	4	4	5	9	22	3	3	4	8	18	6	6	6	18	36
14	71920108L	EN18208737	PRASHANT GALPHADE	4	3	3	5	15	3	3	4*	6	16	6	6	6	12	30
15	71920119F	EN18132459	OMKAR GODHAM	4	3	4	9	20	2	3	4	8	17	6	6	6	18	36
16	71920136F	EN18139867	HUSSAIN RANGWALA	4	3	5	10	22	3	4	4	8	19	8	8	8	20	44
17	71920138B	EN18161401	ABHISHEK JADHAV	5	5	5	8	23	4	4	4	7	19	7	8	7	12	34
18	71920140D	EN18180131	ADITYA JADHAVAR	4	4	4	9	21	5	4	4	7	20	9	9	8	18	44
19	71920144G	EN18256573	VAIBHAV JOGDAAND	3	0	2	7	12	2	0	2	8	12	6	6	6	14	32
20	71920146C		ATHARV JOSHI	3	4	3	2	12	2	3	4	4	13	6	6	5	8	25
21	71920149H	EN18195546	RUTURAJ JCGDAR	4	4	4	8	20	4	4	4	8	20	8	8	8	16	40
22	71920151K	EN18207598	JYOTIPRAKASH SINGH	4	5	5	10	24	5	4	4	9	22	8	8	8	20	44
23	71920153H	EN18177891	DATTARAJ KAJREKAR	4	4	5	8	21	3	4	4	7	18	5	6	5	16	32
24	71920154D	EN18175992	DIPTI KALE	3	4	4	10	21	4	5	4	9	22	8	9	9	18	44
25	71920155B	EN18253665	KALPANA KUMARI	4	4	5	10	23	5	4	4	10	23	8	8	8	20	44
26	71920156L	EN18162568	KALYANI CHOPADE	3	5	5	10	23	4	5	5	9	23	8	8	8	20	44

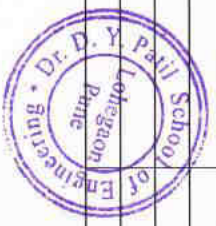

27	71920160J	EN18213861	SANKET KANBLE	4	4	5	4	8	21	4	4	4	8	20	6	6	6	18	36
28	71920162E	EN18124200	MANOJ KAMTHE	4	3	5	5	9	21	4	4	4	10	22	8	8	8	20	44
29	71920163C	EN18174301	SOHAM KAMTHE	4	4	4	5	9	22	3	4	4	8	19	8	8	8	20	44
30	71920168D	EN18205719	SAVREEN KARAJGI	3	4	5	5	9	21	4	4	4	9	22	8	8	8	20	44
31	71920172B	EN18263253	AJAYKUNAR KHAMBHAYTA	4	4	5	5	10	23	5	4	4	9	22	8	8	8	20	44
32	71920320B	EN18168794	SWARAJ KOKATE	4	5	5	5	10	24	4	4	4	8	20	8	8	8	20	44
33	71920190L	EN18160014	RUSHIKESH LOKHANDE	4	4	4	5	10	22	3	4	4	8	20	8	8	8	20	44
34	71920206L	EN18133856	NITIN MISHRA	3	4	4	5	10	23	3	4	4	8	19	8	8	8	20	44
35	71920195M	EN18138970	RAHUL MALI	4	4	5	5	10	23	4	4	4	8	19	8	8	8	20	44
36	71920211G	EN18133869	FAISAL MOMIN	4	4	5	5	10	23	4	4	4	8	20	7	7	6	20	40
37	71920309N	EN18201161	SOHAIL MUGAWAR	4	4	4	5	9	22	3	4	4	7	18	9	8	9	18	44
38	71920224J	EN18233349	NAMRATA HARKE	4	4	4	4	10	22	3	3	4	8	18	6	7	7	20	40
39	71920225G	EN18126441	ANAND NANDINI	5	4	5	5	10	24	4	4	4	9	21	8	8	8	20	44
40	71920227C	EN18127287	NAZIA	4	5	5	5	9	23	4	4	4	8	20	7	7	6	20	40
41	71920229K	EN18108246	YASH NIMBAKAR	4	4	4	5	10	23	3	4	4	9	20	8	8	8	20	44
42	71920231M	EN18119741	OMKAR UTTEKAR	4	4	4	4	9	21	4	4	4	8	20	8	8	8	20	44
43	71920242G	EN18150676	AISHWARYA PATIL	4	5	5	5	10	24	3	4	4	9	20	7	7	8	20	44
44	71920248F	71920248F	BHAVESH PAWAR	5	4	5	5	10	24	4	4	5	8	21	8	8	8	20	44
45	71920250H	EN18213456	MANSI PAWAR	3	4	5	5	10	22	4	4	4	10	22	8	8	8	20	44
46	71920253B	EN18146050	PRAYIN PAVGHAN	4	4	5	5	9	22	5	4	4	10	23	7	6	6	14	32
47	71920256G	EN18115910	ABHIJEET PITTEWAD	4	4	4	4	6	18	2	4	4	7	17	6	6	6	14	32
48	71920259M	EN18136321	PRATIMA GAIRKAWAD	3	5	4	4	10	22	4	5	4	9	22	8	8	8	20	44
49	71920261C	EN18103190	PUSHKAR MAHAMAN	4	4	5	5	10	23	5	4	4	10	23	8	7	7	20	42
50	71920262m	EN18193210	PUSHKAR RAHANE	3	4	4	5	9	21	4	4	4	8	20	8	8	8	20	44
51	71920269J	EN18248768	RISHA BARBERA	4	4	4	4	10	22	4	4	4	9	21	7	6	7	20	40
52	71920272J	EN18122043	ANKITA RODE	4	4	4	4	9	21	4	4	4	9	21	7	7	7	18	40
53	71920176E	EN18136733	SANDESH KHORE	5	4	5	5	8	22	4	4	4	8	20	6	6	6	14	32
54	71920280K	EN18126461	SHUBHAM SARODE	4	5	5	5	10	24	4	4	4	10	22	8	9	8	20	45
55	71920284B	EN18157333	ZOHA SAYYED	4	4	4	5	8	21	4	4	4	9	21	9	8	9	18	44
56	71920053K	EN18168911	SAKSHI BAYVE	4	4	5	5	10	23	4	5	4	9	22	8	8	8	20	44
57	71723582D		PARIKSHIT AHER	4	4	4	4	10	23	4	4	5	8	21	7	6	7	20	40
58	71845636L	SOE1704647	ANNIOL KUNAR SRIVASTAVA	4	4	4	6	6	14	3	0	4	6	13	7	6	7	10	30
59	71723602B	SOE1603586	AYUSH THAKKAR	4	4	4	9	9	21	4	4	4	7	19	6	6	6	18	36
60	71723606E	SOE1603305	ASHVIN BALL	3	5	5	8	8	21	4	4	4	8	20	9	9	8	16	42
61	71627610M	SOE1502548	AJIT CHOCHAN	0	2	3	8	13	13	3	3	4	5	15	6	5	6	8	25
62	71845818E	71845818E	UDDHAV KENDRE	4	4	5	10	23	23	3	3	4	8	18	7	7	6	20	40
63	71937416	SOE1805173	DAKSHIT MAHADESHWAR	4	4	4	8	14	14	0	0	4	8	12	7	8	8	0	23





Roll No.	PRN NO.	ERP No / Application No	Students Name	DBMSL (TW 25 Marks)					CNL (TW 25 Marks)					SDL (TW 50 Marks)				
				UT-I	UT-II	UT-III	Att./ Assgn	Total (25)	UT-I	UT-II	UT-III	Att./ Assgn	Total (25)	UT-I	UT-II	UT-III	Att./ Assgn	Total (50)
64	71845907F	SOE1603346	HENANTKUNAR NIKOLE	0	3	3	6	12	0	3	3	6	12	8	7	8	0	23
65	71845907F	SOE1704148	NISHID WALDE	4	3	5	8	20	4	4	4	9	21	7	8	7	18	40
66	71627825B	SOE1502555	SOHAN SURALKAR	4	5	5	8	22	5	4	4	8	21	7	7	8	16	38
67	71846122D	SOE1704124	VEENISH MOURYA MOURYA	4	4	4	10	22	4	4	4	8	20	8	7	7	20	42
68	71723881E	EN16220072	KARTIK YAMGAR	3	3	3	6	15	2	3	2	6	13	7	7	6	10	30
69	71845879G	SOE1704236	ABHAY MATKAR	4	5	5	10	24	5	4	4	9	22	8	8	8	20	44
72		SOE1704332	BALAJI KAKU	3	3	5	5	16	4	4	4	6	18	6	6	6	12	30
TE-B																		
B-1	71920260	EN18128865	PRIVANKA SAGAR	4	4	5	10	23	5	4	4	10	23	8	8	8	20	44
B-2	71920284L	EN18152043	SHABAZ SHAIKH	4	4	5	5	18	3	4	4	6	17	7	7	6	10	30
B-3	71920287G	EN18184810	ALLAUDIN SHAIKH	3	3	3	9	18	3	3	4	8	18	5	5	5	18	33
B-4	71920289C	EN18146966	AZIM SHAIKH	4	4	4	10	22	4	4	4	9	21	6	6	6	20	38
B-5	71920290G	EN18108236	SHAIKAZ KHAN	4	4	5	8	21	3	4	4	9	20	6	6	6	18	36
B-6	71920297D	EN18221127	RUSHIKESH SHINDE	3	3	4	10	20	3	4	4	9	20	6	6	6	20	37
B-7	71920299L	EN1817499	SHIVANGI SINGH	4	4	5	8	21	4	4	4	9	21	6	5	6	20	35
B-8	71920300H	EN18114484	SHRADHA DHORE	3	4	5	10	22	4	4	4	9	21	6	6	6	20	38
B-9	71845688C	SOE1704323	SHREYA CHAUDHRI	4	5	4	10	23	5	4	5	10	24	8	8	8	20	44
B-10	71920304L	EN18194659	SIDDHARTH CHINCHANKAR	3	3	4	10	20	4	4	4	8	20	6	5	5	20	36
B-11	71920305I	EN18129064	SIDDHARTH RAGHUVANSI	4	4	4	5	17	0	4	4	8	16	7	6	7	10	30
B-12	71920307E	EN18135405	KARAN SINGHASANE	3	3	3	3	12	3	3	4	4	14	6	6	6	8	26
B-13	71845658M	SOE1704330	SINJAN BASU	4	4	4	9	21	5	4	4	9	22	8	8	8	20	44
B-14	71845725M	SOE1704062	SNEHAL DHOLE	3	4	0	8	15	4	4	4	7	19	8	9	8	18	43
B-15	71920308C	EN18102166	SNEHAL KARALE	4	4	5	9	22	4	4	4	9	21	6	6	5	20	37
B-16	71920315F	EN18200888	SUMANT SANKURVAR	5	5	4	10	24	4	5	4	10	23	5	6	6	20	43
B-17	71920046G	EN18115459	TEJAS BAFNA	4	4	5	9	22	4	4	4	9	21	6	6	6	20	37
B-18	71920323C	EN18217533	RUTUDA THOKALE	3	4	4	10	24	4	5	4	10	23	8	8	8	20	44
B-19	71845704J	SOE1704088	UTKARSHA DALVI	4	4	4	8	19	3	4	4	9	22	8	8	7	20	43
B-20	71720303K	EN18108318	DHANASHREE VAIDYA	5	4	5	10	24	5	4	4	9	22	8	5	6	18	35
B-21	71920303H	EN18213818	VARUN PATIL	4	4	5	10	24	5	4	4	9	22	8	8	8	20	44
B-22	71920335L	EN18121038	VINAYAK THUBE	3	3	4	9	19	3	4	4	8	19	6	5	5	18	34
B-23	71920342C	EN18162793	SANGHARATN WAGHMARE	4	4	4	6	18	4	4	4	6	18	10	9	9	10	38
B-24	71920213c	EN18211357	MRTYUNJAY MISHRA	4	3	4	6	17	4	4	4	6	18	8	8	8	10	35



B-25	71920180C	EN18102093	KSHITIZ KUMAR	4	4	4	10	22	4	4	5	9	22	8	8	8	20	44
B-26	71920197H	EN18100982	MANAS JHA	4	4	5	10	23	4	4	4	9	21	7	8	8	20	43
B-27	71920207J	EN18125829	RAFE MOHAMMAD	4	4	5	9	22	4	4	4	8	20	8	8	8	20	44
B-28	71920218D	EN18163314	SHWETA NAIKAWADI	4	3	4	9	20	4	4	4	8	20	7	8	7	20	42
B-29	71920181M	EN18214539	MANSI KULKARNI	3	3	4	9	19	4	3	4	8	19	8	7	8	18	41
B-30	71920192G	EN18189058	RIVA LUNKAD	4	4	5	9	22	5	4	4	8	21	8	8	7	18	41
B-31	71845880L	SOE1704654	NEVIL MEHTA	4	4	5	8	21	3	4	4	8	19	8	8	8	14	38
B-32	7192016D	EN18127934	SURAJ KATORE	3	4	4	10	21	3	4	4	9	20	5	5	5	20	35
B-33	71920184F	EN18169541	YASH KUMBHAR	4	4	5	9	22	3	4	4	8	19	8	8	8	20	44
B-34	71920183K	EN18158858	KULWANT SINGH	2	2	4	5	13	3	4	4	6	17	6	6	6	10	28
B-35	71920276M	EN18129671	SAHL PAWAR	5	5	5	10	25	4	4	5	9	22	7	8	8	20	43
B-36	71920123D	EN18106522	GAURI GOTMARE	4	4	5	10	23	4	4	4	10	22	9	8	8	20	45
B-37	71845734L	SOE1704683	SATYAM DUBE	4	3	4	10	21	3	4	4	9	20	8	7	8	20	43
B-38	71920020C	EN18115453	ADARSH MASKAR	4	4	5	10	23	4	5	4	9	22	8	8	8	20	44
B-39	71920019K	EN18157133	ADARSH MANDALE	3	3	4	10	20	3	3	4	9	19	7	8	8	20	43
B-41	71920265F	EN18106626	PRAITHAMESH RANGNENIWAR	5	3	4	8	20	4	3	4	8	19	6	6	5	18	35
B-42	71845787M	SOE1704092	ABHINAV JAGTAP	2	3	5	9	19	4	4	4	9	21	7	8	7	20	42
B-43	71920165K	EN18197240	RAHUL KANTHI	4	4	4	10	22	4	4	4	8	20	6	5	6	20	37
B-44	71846065M	SOE1704114	ROHIT SONAVANE	4	4	4	9	21	4	4	4	8	20	7	7	7	20	41
B-45	71920288E	EN18102914	ASHRAF SHAIKH	5	4	5	10	24	4	5	4	9	22	8	8	7	20	43
B-46	71920202H	EN18242671	MANVI MOZA	5	4	5	10	24	4	5	5	9	23	8	8	8	20	44
B-47	71920039D	EN18134488	PUSHYARAJ ASNANI	4	4	5	9	22	4	4	4	8	20	8	7	7	20	42
B-48	71920236B	EN18219558	RUTUJA PANDIT	4	4	4	5	17	4	3	4	7	18	10	10	10	40	
B-49	71920230C	EN18109826	NUPUR SHAH	5	4	5	10	24	4	5	4	10	23	8	8	8	20	44
B-50	71920321L	EN18220513	GANESH TAK	4	5	5	10	24	4	4	*4	9	21	7	7	8	20	42
B-51	72008999K	SOE1600619	TRUPTI GAIKWAD	4	4	5	7	20	4	4	4	7	19	8	9	9	16	42
B-52	72008999K	19021011BE182	PRACHI TEKADE	3	4	4	10	21	3	4	4	9	20	8	7	8	20	43
B-53	72008986H	19021011BE180	KUNAL CHAVARE	3	3	4	7	17	4	3	4	7	18	5	6	5	14	30
B-54	72008988D	19021011BE179	HARSHAL GITE	4	4	5	7	20	4	4	4	7	19	6	5	5	14	30
B-55	72008991D	19031011BE287	SHRADDDHA KARANDE	4	4	4	10	22	4	4	4	10	22	8	7	7	20	42
B-56	72008989B	19021101ME4	KAJAL JAGTAP	5	4	5	10	24	4	4	4	8	20	8	8	8	20	44
B-57	72008998M	190101011BE183	SNEHAL POL	5	5	5	10	25	4	5	4	8	21	7	7	8	20	42
B-58	72008993L	190101011BE184	NIKITA LAHANE	5	5	5	9	24	4	4	4	10	22	8	8	8	18	42
B-59	72008985K	19071011BE194	RUTUJA CHAKOR	3	3	4	9	19	3	4	4	8	19	7	8	8	18	41
B-60	72008996E	19021011BE189	SHIVAM DESALE	5	5	5	10	25	4	4	4	10	22	8	7	8	20	43
B-61	72008990F	19061011BE188	DHEERAJ KACHI	3	4	4	10	21	4	4	4	8	20	8	8	8	20	44
B-62	72008992B	19011011BE192	ANURAG KULKARNI	5	5	5	10	25	4	3	4	8	19	7	7	8	20	42



B-63	72008995G	190101011BE191	AKSHATA PAWAR	3	4	4	9	20	4	3	4	4	7	18	8	8	7	18	41
B-64	72008994J	190111011BE193	PALLAVI OPALKAR	3	4	4	10	21	3	4	4	4	9	20	7	7	7	20	41
B-65	72008997C	19051011BE195	SHUBHAM PAKAL	4	4	5	7	20	0	4	4	4	9	17	5	5	4	14	28
B-66	717236181	SOE1603378	ADVAIT BHUBAL	4	4	5	10	23	4	4	4	4	8	20	8	8	8	20	44
B-67	71845724C	SOE1704177	SWAPNA DHOBALE	3	3	3	5	14	4	3	4	4	6	17	5	5	5	10	25
B-68	71845962J	SOE1704186	ANANDKUMAR RAI	3	4	5	7	19	4	4	4	4	7	19	6	5	5	16	32
B-69	71845622L	SOE1704643	AGRAWAL GAURAV KHEMCHAND	4	3	5	7	19	3	3	4	4	7	17	9	8	9	16	42
B-70	71845891F	SOE1704103	BHAGYASHREE SIDDARAM MUDDADAGI	4	5	4	9	22	4	4	4	4	10	22	8	8	7	20	43
B-71	71846062G	SOE1704108	SONALVIJAY MORE	4	4	4	10	22	4	4	4	4	10	22	7	7	8	20	42
B-72		SOE1502784	WAGH ANIKET RAJENDRA	3	3	5	4	15	3	4	4	4	6	17	5	6	5	12	28



Dr. D. Y. Patil Technical Campus

# **Dr. D. Y. Patil School of Engineering**

Dr. D. Y. Patil Knowledge City, Charholi (Bk), Lohegaon, Pune – 412 105

## **5. List of Non-working days and Holidays.**

# सावित्रीबाई फुले पुणे विद्यापीठ

(पूर्वीचे पुणे विद्यापीठ)



परिपत्रक क्र. ३.६२/२०२०

विषय : सन २०२१ च्या सार्वजनिक सुट्या...

महाराष्ट्र शासन, अधिसूचना क्रमांक सार्वसु. ११२०/प्र.क्र.८२/कार्या-२९.-परक्राम्य संलेख अधिनियम, १८८१ (सन १८८१ चा अधिनियम २६) कलम २५ करीता जे अधिकार भारत सरकारच्या गृह मंत्रालयाची अधिसूचना क्रमांक: ३९/१/६८, जेयूडीएल/तीन, दिनांक ८ मे, १९६८ अन्वये महाराष्ट्र शासनास सोपविण्यात आल्या आहेत, त्या अधिकारांचा वापर करून, महाराष्ट्र शासनाने दिनांक ०१ डिसेंबर, २०२० च्या अधिसूचनेद्वारे महाराष्ट्र राज्यात शासकीय कार्यालयांना सन २०२१ साठी खाली नमूद केलेल्या सार्वजनिक सुट्या जाहीर केल्या आहेत. सदर सार्वजनिक सुट्या सावित्रीबाई फुले पुणे विद्यापीठ शिक्षकेतर सेवकांना व सावित्रीबाई फुले पुणे विद्यापीठाशी संलग्न महाविद्यालये/मान्यताप्राप्त संस्थेतील शिक्षकेतर सेवकांना जाहीर केलेल्या आहेत.

अ.क्र.	सुट्टीचा दिवस	इंग्रजी तारीख	वार
१.	प्रजासत्ताक दिन	२६ जानेवारी, २०२१	मंगळवार
२.	छत्रपती शिवाजी महाराज जयंती	१९ फेब्रुवारी, २०२१	शुक्रवार
३.	महाशिवरात्री	११ मार्च, २०२१	गुरुवार
४.	होळी (दुसरा दिवस)	२९ मार्च, २०२१	सोमवार
५.	गुड फ्रायडे	०२ एप्रिल, २०२१	शुक्रवार
६.	गुढीपाडवा	१३ एप्रिल, २०२१	मंगळवार
७.	डॉ.बाबासाहेब आंबेडकर जयंती	१४ एप्रिल, २०२१	बुधवार
८.	रामनवमी	२१ एप्रिल, २०२१	बुधवार
९.	रमझान ईद (ईद-उल-फितर) (शब्बल-१)	१३ मे, २०२१	गुरुवार
१०.	बुध्द पौर्णिमा	२६ मे, २०२१	बुधवार
११.	बकरी ईद (ईद-उल-झुआ)	२१ जुलै, २०२१	बुधवार
१२.	पारशी नववर्ष दिन (शहेनशाही)	१६ ऑगस्ट, २०२१	सोमवार
१३.	मोहरम	१९ ऑगस्ट, २०२१	गुरुवार
१४.	गणेश चतुर्थी	१० सप्टेंबर, २०२१	शुक्रवार
१५.	दसरा	१५ ऑक्टोबर, २०२१	शुक्रवार
१६.	ईद-ए-मिलाद	१९ ऑक्टोबर, २०२१	मंगळवार
१७.	दिवाळी अमावस्या (लक्ष्मीपूजन)	०४ नोव्हेंबर, २०२१	गुरुवार
१८.	दिवाळी (बलिप्रतिपदा)	०५ नोव्हेंबर, २०२१	शुक्रवार
१९.	गुरुनानक जयंती	१९ नोव्हेंबर, २०२१	शुक्रवार
२०.	ख्रिसमस	२५ डिसेंबर, २०२१	शनिवार

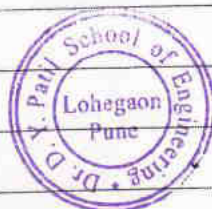

शासनाने जाहीर केलेल्या अधिसूचनान्वये पाच सुट्ट्या (क) या शनिवारी तसेच रविवारी आलेल्या आहेत. शासनास पाच दिवसांचा आठवडा त्याचप्रमाणे राज्य शासकीय, निमशासकीय कार्यालये, संघटना, शासनाचे उपक्रम तसेच राज्य शासनाच्या प्रशासकीय विभागांच्या नियंत्रणाखालील कार्यालये यांच्यासाठी खालील अतिरिक्त सुट्टी जाहीर केलेली आहे.

अ.क्र.	सुट्टीचा दिवस	इंग्रजी तारीख	वार
१	भाऊबीज	०६ नोव्हेंबर, २०२१	शनिवार

- टीप :- १. मा.विभागीय आयुक्त, पुणे विभाग, पुणे हे ज्या स्थानिक सुट्ट्या जाहीर करतील, त्या स्थानिक सुट्ट्या विद्यापीठ कार्यालयास आणि पुणे जिल्ह्यातील संलग्न महाविद्यालये व मान्यताप्राप्त संस्था यांना देण्यात येतील. तसेच मा.विभागीय आयुक्त, नाशिक व अहमदनगर विभाग यांनी वेळोवेळी जाहीर केलेल्या स्थानिक सुट्ट्या नाशिक व अहमदनगर जिल्ह्यातील सावित्रीबाई फुले पुणे विद्यापीठाची उपकेंद्रे, संलग्न महाविद्यालये व मान्यताप्राप्त संस्थांसाठी लागू होतील.
२. संलग्न महाविद्यालये/मान्यताप्राप्त संस्थेतील शिक्षकेतर सेवकांना जाहीर केलेल्या सुट्ट्यांमधील काही सुट्ट्या देता येणे शक्य नसल्यास त्यांना त्या बदल्यात कार्यालयीन सोयीनुसार पर्यायी सुट्टी देय होईल.

  
(डॉ.प्रफुल्ल पवार)  
कुलसचिव

गणेशखिंड, पुणे - ४११ ००७  
जा.क्र. : एएन/५४/२५  
दिनांक : ३० DEC २०२०

प्रत माहिती व योग्य त्या कार्यवाहीसाठी :-

१. मा.विभागप्रमुख, सर्व शैक्षणिक विभाग
२. मा.शाखाप्रमुख, सर्व प्रशासकीय शाखा
३. मा.प्राचार्य, विद्यापीठाशी संलग्न सर्व महाविद्यालये
४. मा.संचालक, विद्यापीठाच्या मान्यताप्राप्त सर्व संस्था
५. मा.कुलसचिव, महाराष्ट्रातील सर्व अकृषि विद्यापीठे

यांना विनंती की वरील परिपत्रकाचा आशय सर्व संबंधितांच्या निदर्शनास आणून द्यावा.

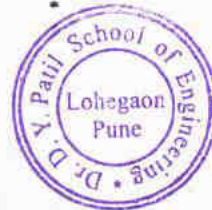

Dr. D. Y. Patil Technical Campus

# **Dr. D. Y. Patil School of Engineering**

Dr. D. Y. Patil Knowledge City, Charholi (Bk), Lohegaon, Pune – 412 105

## 1) Departmental Time Table



Dr. D. Y. Patil Technical Campus  
Dr. D. Y. Patil School of Engineering  
Dr. D. Y. Patil Knowledge City, Charholi (Bk), Lohgaon, Pune - 412 105  
Website: [www.dypic.in](http://www.dypic.in)

Form No.: IQAC3

Revision: 01  
Date: 08/03/2021

Marks-30

**Department of Engineering Sciences(FE)**

Platform : Microsoft teams/LMS

**Time Table For Online Class Test -I, Semi-I, 2020-21**

Syllabus - Unit- I, II

Day	DATE	TIME	FE-A	FE-B	FE-C	FE-D
Monday	15/03/2021	3:30 pm to 4:30 pm	M-I	M-I	M-I	M-I
Tuesday	16/03/2021	3:30 pm to 4:30 pm	SME	SME	SME	SME
Wednesday	17/03/2021	3:30 pm to 4:30 pm	EP	EP	EC	EC
Thursday	18/03/2021	3:30 pm to 4:30 pm	BEE	BEE	BXE	BXE
Friday	19/03/2021	3:30 pm to 4:30 pm	PPS	PPS	EM	EM

Prof. V D Tirpude  
Prof. A M Uphad  
Exam coordinators



Dr. S M Khairnar  
Head of Dept. (FE)

Dr. Ashok Kasnale  
Principal





Dr. D. Y. Patil Technical Campus  
Dr. D. Y. Patil School of Engineering  
Dr. D. Y. Patil Knowledge City, Charholi (Bk), Lohgaon, Pune - 412 105  
Website: [www.dypic.in](http://www.dypic.in)

Form No.: IQAC3

Revision: 01  
Date: 01/04/2021

Platform : Microsoft Team

Syllabus - Unit- I, II, III & IV

Max. Questions : 60

### Department of Engineering Sciences(FE)

Time Table For Mock Test (Unit Test-II) for End Sem Exam, Semester-I, A.Y. 2020-21

DAY	DATE	TIME	FE-A	FE-B	FE-C	FE-D
Tuesday	06/04/2021	10:00 am To 11:00 am	M-I	M-I	M-I	M-I
Wednesday	07/04/2021	10:00 am To 11:00 am	BEE	BEE	BXE	BXE
Thursday	08/04/2021	10:00 am To 11:00 am	SME	SME	SME	SME
Friday	09/04/2021	10:00 am To 11:00 am	EP	EP	EC	EC
Saturday	10/04/2021	10:00 am To 11:00 am	PPS	PPS	EM	EM

Prof. V D Tirpude  
Exam coordinator



Dr. S M Khairnar  
Head of Dept. (FE)

Dr. Ashok Kasnale  
Principal



Dr. D. Y. Patil Technical Campus  
 Dr. D. Y. Patil School of Engineering  
 Dr. D. Y. Patil Knowledge City, Charholi (Bk), Lohgaon, Pune – 412 105  
 Website: [www.dypic.in](http://www.dypic.in)

Form No.: IQAC3  
 Revision:01  
 Date: 22/07/2021  
 Platform:  
 Microsoft Team/LMS

**Department of Engineering Sciences(FE)**  
**Time Table For FE Dept. Class Test-III, Semester -II,**  
**AY : 2020-21 , FE (2019 Pattern)**

Marks-30	Duration: 40 Min	Syllabus -Unit- V & VI						
Day	DATE	TIME SLOT	SUBJECT	SUBJECT CODE	DIVISION	SUBJECT	SUBJECT CODE	DIVISION
Monday	26/07/2021	11:00 AM - 11:40 AM (40 Minutes)	Engineering Mathematics-II	107008	FE-A & FE-B	Engineering Mathematics-II	107008	FE-C
Tuesday	27/07/2021	11:00 AM - 11:40 AM (40 Minutes)	Engineering Chemistry	107009		Engineering Physics	107002	FE-C
Wednesday	28/07/2021	11:00 AM - 11:40 AM (40 Minutes)	Basic Electronics Engineering	104010	FE-B & FE-D	Basic Electrical Engineering	103004	&
Thursday	29/07/2021	11:00 AM - 11:40 AM (40 Minutes)	Engineering Graphics	102012		Engineering Graphics	102012	FE-D
Friday	30/07/2021	11:00 AM - 11:40 AM (40 Minutes)	Engineering Mechanics	101011		Programming & Problem Solving	110005	

Prof. V D Tirpude  
 FE Exam coordinator



Dr. S M Khairnar  
 Head of Dept. (FE)

Dr. F.B.Sayad  
 Principal

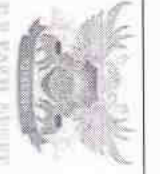

Dr. D. Y. Patil Technical Campus  
Dr. D. Y. Patil School of Engineering  
Dr. D. Y. Patil Knowledge City, Charnoli (BK), Lohgaon, Pune – 412 105  
Website: [www.dypic.in](http://www.dypic.in)

Form No.: IQAC3

Revision: 01  
Date: 01/06/2021

Platform:  
Microsoft Team/LMS

Marks-30

Duration: 40 Min

**Department of Engineering Sciences(FE)**  
**Time Table For Dept. Class Test-I, Semester -II, AY : 2020-21**  
**FE (2019 Pattern)**

Syllabus - Unit-I, II

Day	DATE	TIME SLOT	SUBJECT	SUBJECT CODE	DIVISION	SUBJECT	SUBJECT CODE	DIVISION
Friday	11/06/2021	10:00 AM - 10:40 AM (40 Minutes)	Engineering Mathematics-II	107008	FE-A &	Engineering Mathematics-II	107008	FE-C &
Friday	11/06/2021	3:00 PM - 3:40 PM (40 Minutes)	Engineering Chemistry	107009		Engineering Physics	107002	
Saturday	12/06/2021	10:00 AM - 10:40 AM (40 Minutes)	Basic Electronics Engineering	104010	FE-B	Basic Electrical Engineering	103604	FE-D
Saturday	12/06/2021	3:00 PM - 3:40 PM (40 Minutes)	Engineering Mechanics	101011		Programming & Problem Solving	110005	

Prof. V D Tirpude  
FE Exam coordinator



Dr. S M Khairnar  
Head of Dept. (FE)

Dr. Ashok Kasnate  
Principal



Dr. D. Y. Patil Technical Campus  
Dr. D. Y. Patil School of Engineering  
Dr. D. Y. Patil Knowledge City, Charholi (Bk), Lohgaon, Pune – 412 105  
Website: [www.dypic.in](http://www.dypic.in)

Form No.: IQAC3

Revision: 01

Date: 05/07/2021

Platform:  
Microsoft Team/LMS

### Department of Engineering Sciences(FE)

#### Time Table For FE Dept. Class Test-II, Semester -II,

AY : 2020-21 , FE (2019 Pattern)

Syllabus -Unit- III, IV

Marks-30	Duration: 40 Min	Time Table For FE Dept. Class Test-II, Semester -II, AY : 2020-21 , FE (2019 Pattern)						Syllabus -Unit- III, IV
Day	DATE	TIME SLOT	SUBJECT	SUBJECT CODE	DIVISION	SUBJECT	SUBJECT CODE	DIVISION
Saturday	10/07/2021	11:00 AM - 11:40 AM (40 Minutes)	Engineering Mathematics-II	107008	FE-A & FE-B	Engineering Mathematics-II	107008	FE-C & FE-D
Saturday	10/07/2021	11:00 AM - 11:40 AM (40 Minutes)	Engineering Chemistry	107009		Engineering Physics	107002	
Sunday	11/07/2021	11:00 AM - 11:40 AM (40 Minutes)	Basic Electronics Engineering	104010		Basic Electrical Engineering	103004	
Sunday	11/07/2021	11:00 AM - 11:40 AM (40 Minutes)	Engineering Mechanics	102012		Programming & Problem Solving	102012	

Prof. V D Tirpude  
FE Exam coordinator



Dr. S M Khalraar  
Head of Dept. (FE)

Dr. F. B. Sayyad  
Principal



Dr. D. Y. Patil Technical Campus  
 Dr. D. Y. Patil Knowledge City, Chautholi (Bk), Lohgaon, Pune - 412 105  
 Department of Electronics and Telecommunication Engineering

### AY 2021-22 Master Time Table Sem - I

Form No.: IQACT7  
 Revision: 05  
 Date: 1-10-2021 Tuesday

### Timetable w. e. f. 1/10/2021

Time	Year -Div.	Monday	Tuesday	Wednesday	Thursday	Friday
10.30 am to 11.30 am	BE	RMT(SKH)	CNS(AB)	VLSI(RM)	DIVP(SMK)	AI(RM)
	TE	DSP(PKH)	EMT(SKH)	MC(SP)	EMT(SKH)	Robotics
	SE	DS(SK)	DS(SK)	EM-III(BG)	EC(RLK)	ESD(PKH)
11.30 am to 12.30 pm	BE	CNS(AB)	RMT(SKH)	AI(RM)	VLSI(RM)	DIVP(SMK)
	TE	EMT(SKH)	DM(SK)	DSP(PKH)	EMT(SKH)	SD(RLK)
	SE	DC(SA)	Elect. Ckt. (ASB)	EC(RLK)	EM-III(BG)	DS(SK)
Lunch Break						
1.00 pm to 2.00 pm	BE	VLSI(RM)	DIVP(SMK)	RMT(SKH)	CNS(AB)*	CNS(AB)
	TE	DM(SK)	DC(SM)	DM(SK)	MC(SP)	MC(PR)(SP)
	SE	EM-III(BG)	DC(SA)	EM-III(BG)	DC(SA)	EC(RLK)
2.00 pm to 3.00pm	BE	AI(RM)	LP-II DIVP(PR)(SMK)	LP-I RMT (PR) (SKH)	LP-II VLSI(PR) (RM)	Project Stage-I
	TE	DC(SM)	MC(SP)	DC(SM)	DSP(PKH)	SD(PR)(RLK)
	SE	Elect. Ckt. (ASB)	DC(PR)(SA)	DS(PR)(SK)	Elect. Ckt. (ASB)	Elect. Ckt. (PR)(ASB)
3.00 pm to 4.00 pm	BE	LP-I				
	TE	CNS(PR)(AB)				
	SE	DC(PR)(SM)	DM(PR)(SK)	DSP(PR)(PKH)	Robotics	
	SE	EC(PR)(RLK)				



Notes: Fortnight And Dracticals Are To Be Conducted At The Allotted Times Only.



Class	Notation	Name of The Subject	Notation	Name of The Faculty	
SE	EM	Engineering Mathematics-III	BG	Prof. Bhagavat Gidhad	
	EC	Electronic Circuits	RLK	Prof. Riyaj Kazi	
	DC	Digital Circuits	SA	Dr. Saniya Ansari	
	Elect. Ckt	Electrical Circuits	ASB	Prof. Aruna Bingi	
	DS	Data Structures	SK	Prof. Swati Kadu	
	ESD	Electronic Skill Development	PKH	Prof. Prajakta Khairnar	
	DC	Digital Communication	SM	Prof. Sayali Mane	
	EMT	Electromagnetic Field Theory	SKH	Prof. Swati Khawate	
	DM	Database Management	SK	Prof. Swati Kadu	
	MC	Microcontrollers	SP	Prof. Shital Patil	
TE	DSP	Elective - I Digital Signal Processing	PKH	Prof. Prajakta Khairnar	
	SD	Skill Development	RLK	Prof. Riyaj Kazi	
	HS	Robotics(Honor Subject)	SA	Dr. Saniya Ansari	
	VLSI	VLSI(RM) Design & Technology	RM	Dr. Rashmi Mahajan	
	CNS	Computer Networks & Security	AB	Prof. Ashwini Bagde	
	RMT	Radiation & Microwave Techniques	SKH	Prof. Swati Khawate	
	DIVP	Elective I- Digital Image and Video Processing	SMK	Dr. S. M. Koli	
	EPD	Elective II- Artificial Intelligence	SA	Dr. Rashmi Mahajan	
	SE	<b>Class Teachers</b>			
		Prof. Prajakta Khairnar	TE	Prof. Sayali Mane	BE

Prof. Swati S. Khawate  
Time Table in charge



Dr. S. M. Koli  
HOD E&TC



Dr. F. B. Sayyad  
Principal



Dr. D. Y. Patil Technical Campus

# Dr. D. Y. Patil School of Engineering

Dr. D. Y. Patil Knowledge City, Chaholi (Bk), Lohgaon, Pune - 412 105  
Department of Electronics and Telecommunication Engineering

Form No.:IQAC/7

Revision:07

AY 2020-21 Master Time Table Sem-II w. e. f.22/02/2021

Date:22/02/2021 Monday

Time	Year -Div.	Monday	Tuesday	Wednesday	Thursday	Friday
10.00am to 11.00am	BE	ML(NBS)	WSN (EL-IV)(RLK)	BCS(PKH)	PS-II(NBS)	PS-II(NBS)
	TE	SPOS(FB)	ITCCN(SMK)	BM(SK)	AP(RPM)	PE (RLK)
	SE	SS(GT)	SS(GT)	PCS(SA)	CS(AB)	SS(GT)
11.00am to 12.00pm	BE	WSN (EL-IV)(RLK)	BCS (PKH)	MC (SK)	BCS(PKH)	PS-II(NBS)
	TE	AP(RPM)	PE(RLK)	AP (RPM)	BM(SK)	SPOS(FB)
	SE	CS(AB)	OOPS(NBS)	CS(AB)	SS(GT)	PCS(SA)
Lunch Break						
1.00pm to 2.00pm	BE	MC (SK)	MC (SK)	ML(NBS)	ML(NBS)	PS-II(GT)
	TE	ES&MP(SA)	AP(RPM)	PE(RLK)	ITCCN(SMK)	ITCCN (SMK)
	SE	OOPS(NBS)	OOPS(NBS)	ESD(PK)	PCS(SA)	ESD(PK)
2.00pm to 3.00pm	BE	PS-II(SMK)	PS-II(RM)	PS-II(SA)	PS-II(GT)	PS-II(RLK)
	TE	BM(SK)	SPOS(FB)	ITCCN(SMK)	ES&MP(SA)	
	SE					

Time Table



A.Y. 2020-21 (Sem-II)



Note: Lectures And Practical's Are To Be Conducted At The Allotted Location Only.

Year	Notation	Name of The Subject	Notation	Name of The Faculty	
SE	EM	Engineering Mathematics	BG	Prof. Bhagawat Gidhad	
	EC	Electronic Circuits	RLK	Prof. RiyajKazi	
	DC	Digital Circuits	NBS	Prof. NishikantSurwade	
	Elect. CKt	Electrical Circuits	RG	Prof. Tejpal R. Pardeshi	
	DS	Data Structures	FB	Prof. FarazBagwan	
TE	ITCCN	Information Theory, Coding and Communication Networks	SMK	Dr. S. M. Koli	
	AP	Advanced Processors	RM	Dr. RashmiMahajan	
	PE	Power Electronics	RLK	Prof. RiyajKazi	
	BM	Business Management	SK	Prof. Swati Khawate	
	SPOS	System Programming and Operating Systems	FB	Prof. FarazBagwan	
BE	ES&MP	Employability Skills and Mini Project	SA	Dr. Saniya Ansari	
	MC	Mobile Communication	SK	Prof. Swati Khawate	
	BCS	Broadband Communication Systems	PKH	Prof. Prajaktakhairnar	
	ML	Machine Learning ( Elective III )	NBS	Prof. NishikantSurwade	
	WSN	Wireless Sensor Networks ( Elective IV )	RLK	Prof. RiyajKazi	
<b>Class Teachers</b>					
SE	Prof. Prajaktakhairnar	TE	Prof. Riyaj Kazi	BE	Prof. Swati Khawate

Prof. Swati S. Khawate  
Time Table in charge

Dr. S. M. Koli  
HOD E&TC

Dr. Ashok Kasnale  
Principal



Time Table

A.Y. 2020-21 (Sem-II)





Code	Subject	Faculty Load													Total					
		PA	SR	PS	JC	AC	CB	VM	VC	AP	MD	AM	NM	PM		VB	NU	FB	PDS	PSG
<b>(FE) / (No of Students)</b>																				
11005	Programming and Problem Solving	3	2	6	0	0	2	12	18	18	18	18	18	18	18	18	18	18	18	18
<b>(SE) / (No of Students - I)</b>																				
210341	Discrete Mathematics	3		6	1	2	0	0	0	0	0	0	0	0	0	0	0	0	0	0
210342	Fundamentals of Data Structures	3		6	0	0	0	0	0	0	0	0	0	0	0	0	0	0	0	0
210343	Object Oriented Programming	3		6	0	0	0	0	0	0	0	0	0	0	0	0	0	0	0	0
210344	Computer Graphics	3		6	0	0	0	0	0	0	0	0	0	0	0	0	0	0	0	0
210345	Digital Electronics and Logic Design	3		6	0	0	0	0	0	0	0	0	0	0	0	0	0	0	0	0
210346	Humanity and Social Science	3	2	6	0	0	0	0	0	0	0	0	0	0	0	0	0	0	0	0
210347	Data Structures Lab	0		0	1	2	0	0	0	0	0	0	0	0	0	0	0	0	0	0
210348	Computer Graphics COP Lab	0		0	0	0	0	4	24	24	24	24	24	24	24	24	24	24	24	24
210349	Digital Electronics Lab	0		0	0	0	2	12	12	12	12	12	12	12	12	12	12	12	12	12
210349	Business Communication Skills Lab	0		0	0	0	2	12	12	12	12	12	12	12	12	12	12	12	12	12
<b>(BE) / (No of Students - I)</b>																				
310241	Theory of Computation	3		6	0	0	0	0	0	0	0	0	0	0	0	0	0	0	0	0
310242	Databases Management Systems	3		6	0	0	0	0	0	0	0	0	0	0	0	0	0	0	0	0
310243	Software Eng. & Proj Mgmt	3		6	0	0	0	0	0	0	0	0	0	0	0	0	0	0	0	0
310244	Information Systems &	3		6	0	0	0	0	0	0	0	0	0	0	0	0	0	0	0	0
310245	Computer Networks	3	2	6	0	0	0	0	0	0	0	0	0	0	0	0	0	0	0	0
310246	Skills Development Lab	0		0	2	4	4	4	24	24	24	24	24	24	24	24	24	24	24	24
310247	DHMS Lab	0		0	0	0	2	12	12	12	12	12	12	12	12	12	12	12	12	12
310248	C# Lab	0		0	0	0	2	12	12	12	12	12	12	12	12	12	12	12	12	12
310249	Audit Course 3	0		0	0	0	2	12	12	12	12	12	12	12	12	12	12	12	12	12
<b>(BE) / (No of Students - I)</b>																				
410241	High Performance Computing	4		8	0	0	0	0	0	0	0	0	0	0	0	0	0	0	0	0
410242	Artificial Intelligence and Robotics	3		6	0	0	0	0	0	0	0	0	0	0	0	0	0	0	0	0
410243	Data Analytics	3		6	0	0	0	0	0	0	0	0	0	0	0	0	0	0	0	0
410244	Electric I	3		6	0	0	0	0	0	0	0	0	0	0	0	0	0	0	0	0
410245	Electric II	3	2	6	0	0	0	0	0	0	0	0	0	0	0	0	0	0	0	0
410246	Laboratory, Practice I	0		0	0	0	0	4	24	24	24	24	24	24	24	24	24	24	24	24
410247	Laboratory, Practice II	0		0	0	0	0	4	24	24	24	24	24	24	24	24	24	24	24	24
410248	Project Work stage I	0		0	0	0	2	60	60	60	60	60	60	60	60	60	60	60	60	60
410249	Laudit Course 5	0		0	0	0	2	12	12	12	12	12	12	12	12	12	12	12	12	12
<b>(SE-EMTC) / (No of Students)</b>																				
510241	Data Structures	3	1	3	0	0	2	6	6	6	6	6	6	6	6	6	6	6	6	6
<b>Total</b>																				
Grand Total Load		410	100	352	8	0	352	359	359	359	359	359	359	359	359	359	359	359	359	359

Note- Excluded Hours allocated for M.E.

Total Load (Excluding M.E hrs)	TH	TUT	PR
369	109	8	252
Avg Load / Faculty	18		
No of faculties Required	19		
No of faculties available	16		
No. of faculties from Emc dept	1		
No. of faculties shared to FE dept and Emc dept	2		
Additional No of faculties required	2		

Prof. Jayashree Chaudhari  
Time Table Incharge

Sr. Faculty	Name of Faculty	Faculty load																			
		PA	SR	PS	JC	AC	CB	VM	VC	AP	MD	AM	NM	PM	VB	NU	FB	PDS	PSG	PK	
1	Dr. Pankaj Agarkar								4												
2	Dr. Sunil Rathod																				
3	Prof. Pallavi Shimpi																				
4	Prof. Jayashree Chaudhari																				
5	Prof. Amruta Chitani																				
6	Prof. Chaitanya Bhosale																				
7	Prof. Yogesh Mali																				
8	Prof. Vandana Charvan																				
9	Prof. Ashwini Paradgale																				
10	Prof. Monika Dangore																				
11	Prof. Ayush Mahapatra																				
12	Prof. Nilesh Mali																				
13	Prof. Prashant Mandale																				
14	Prof. Vishal Borote																				
15	Prof. Nivarnat U.																				
16	Prof. Parizh Bagwan																				
17	Prof. Deegn Shinde																				
18	Prof. Prashant Sangar																				
Faculty from Emc Department		19	PK	PK																	
Prof. Pratikta																					

Dr. Pankaj Agarkar  
HOD

Dr. Pankaj Agarkar  
Dean(Academic)

Head of the Department  
Department of Computer Engineering  
Dr. D. Y. Patil School of Engineering  
Dr. D. Y. Patil Technical Campus  
Via Lonargaon, Charholi Bk., Pune-412105

Dr. Asha Kamate  
Principal





"Empowerment through quality technical education"  
 Dr Ajeenkya DY Patil Knowledge City, Charcholi (Bk), Via. Lohgaon,  
 Pune - 412 105

Dr D Y Patil School of Engineering  
 Department of Computer Engineering  
 Lockdown TimeTable Sem - II (2020-2021) ver 1.1

Date : 01 Feb 2021

	SE					TE					BE				
	10:30 - 11:30	11:30 - 12:30	1:00 - 2:00	2:00 - 3:00	3:00 - 4:00	10:30 - 11:30	11:30 - 12:30	1:00 - 2:00	2:00 - 3:00	3:00 - 4:00	10:30 - 11:30	11:30 - 12:30	1:00 - 2:00	2:00 - 3:00	
MON	Div A	ADS (PM)	SE (PDS)	M-II (BG)	PBL (VC)	SMD(FB)	SPOS(AC)	DA(A&MD)	ESLOT(CB)		EL-III(PS)	ML(SR)	EL-IV(YM)	LP-III(SR)	
	Div B	SE (PDS)	ADSL (NM)	ADS (NM)	M-III (BG)	M-III -TUT (RK)	ESLOT(CB)	DA(A&MD)	SPOS(NU)	SMD(FB)	EL-IV(PA)	ML(C)	EL-III(PS)	LP-III(AP/C)	
TUES	Div A	PPL (VC)	MP (SP)	ADSL (PM)	SE(PDS)	COG (PM)	ESLOT(CB)	SPOS(AC)	DA(A&MD)	ESLOT(LA M)	EL-IV(YM)	EL-III(PS)	ICS(AP)	LP-IV(YM)	
	Div B	ADSL (NM)	SE (PDS)	MP (SP)	PRL(VC)		DA(A&MD)	ESLOT(CB)	SPOS(NU)		EL-III(PS)	ICS(AP)	EL-IV(PA)	LP-IV(PS/PA)	
WED	Div A	M-III (BG)	ADS (PM)	MPL (SP)	M-III -TUT (RK)	PBL(VC)	ESLOT(CB)	SMD(FB)	WT(VB)	SPOS(LAC)	EL-III(PS)	ML(SR)	ICS(AP)	LP-III(AP/SR)	
	Div B	MPL (SP)	M-III (BG)	ADS (NM)	PBL(PDS)		SMD(FB)	WT(VB)	ESLOT(CB)	SPOS(LAC)	ICS(AP)	*ML(C)	EL-III(PS)	LP-III(C)	
THURS	Div A	PPL (VC)	ADSL (PM)	MP (SP)	M-III (BG)		WT(VB)	DA(A&MD)	SPOS(AC)	ESLOT(CB)	ICS(AP)	EL-IV(YM)	ML(SR)	LP-IV(YM)	
	Div B	MP (SP)	PPL (VC)	M-III (BG)	PBL (PDS)	COC (NM)	DA(A&MD)	SPOS(NU)	ESLOT(CB)	WT(VB)	EL-IV(PA)	ICS(AP)	ML(C)	LP-IV(PS/PA)	
FRI	Div A	SE (PDS)	PPL (VC)	ADS (PM)	MP(SP)		WT(VB)	SPOS(AC)	DA(A&MD)	SMD(FB)	Project Work Stage II	Project Work Stage II	Project Work Stage II	Project Work Stage II	
	Div B	MP(SP)	ADS (NM)	SE (PDS)	PPL (VC)		DA(A&MD)	SMD(FB)	WT(VB)	SPOS(NU)	Project Work Stage II	Project Work Stage II	Project Work Stage II	Project Work Stage II	

Class	Subject	Name of Subject	Teacher	Name of the Teacher
SE	EM-III	Engineering Mathematics III	BG &	Prof. Bhagwad Gridhad & Dr. Rahul kumar
	ADS	Advanced Data Structures	NM &	Prof. Nilesh Mali & Prof. Prashant Mandale
	SE	Software Engineering	PDS	Prof. Pooja Shinde
	MP	Microprocessor	SP	Prof. Shital Patil
	PPL	Principles of Programming Lang.	VC	Prof. Vandana Chavran
	ADSL	Advanced Data Structures Lab	NM &	Prof. Nilesh Mali & Prof. Prashant Mandale
SE	MPL	Microprocessor Lab	SP	Prof. Shital Patil
	PBL	Project Based Learning II	VC &	Prof. Vandana Chavran & Prof. Pooja Shinde



TE

COC	Code of Conduct	NM &	Prof. Nilesh Mali & Prof. Prashant Vundale
DAA	Design & Analysis of Algorithm	MD	Prof. Monika Dangore
SPOS	System Prog. & Operating System	AC &	Prof. Anruta Chitani & Prof. Niyamat U.
ESIoT	Embedded Systems & IoT	CB	Prof. Chaitanya Bhosale.
SMD	Software Modeling and Design	FB	Prof. Faraz Bhagwan
WT	Web Technology	VB	Prof. Vishal Borate
STC	Seminar & Tech. Communication	SR	Prof. Sunil Rathod
WTL	Web Technology Lab	MD & VB	Prof. Monika Dangore and Prof. Vishal Borate
SPOS	SP & OS Lab	AC &	Prof. Anruta Chitani & Prof. Niyamat U.
ESIoT	ES & IoT Lab	CB & FB	Prof. Chaitanya Bhosale & Prof. Faraz Bhagwan
ML	Machine Learning	SR & JC	Dr. Sunil Rathod & Prof. Jayashree Chaudhari
ICS	Information and Cyber Security	AP	Prof. Ashwini Pandagale
EL-III	Elective III	PS	Prof. Pallavi Shimpi
EL-IV	Elective IV	PA &	Dr. Pankaj Agarkar & Prof. Yogesh Mali
LP-III	Laboratory Practice III	SR & JC	Dr. Sunil Rathod & Prof. Jayashree Chaudhari &
LP-IV	Laboratory Practice IV	PA &	Dr. Pankaj Agarkar & Prof. Yogesh Mali & Prof. Pallav
PW-II	Project Work Stage II	MID	Prof. Monika Dangore

*Jayashree*  
Prof. Jayashree Chaudhari  
Time Table Coordinator

*Pankaj*  
Dr. Pankaj Agarkar  
Hod



**Head of the Department**  
Department of Computer Engineering  
Dr. D. Y. Patil School of Engineering  
Dr. D. Y. Patil Technical Campus  
Via Lohagson, Charhol Br., Pune-412 105



**EMPOWERMENT THROUGH ACADEMIC EXCELLENCE**

**Master Time Table of Mechanical Department, AY 2020-21, Sem - I, w. e. f. 07/09/2020**

Day	TIME	SE - A	SE - B	TE - D	TE - E	TE - F	BE - G	BE - H	BE - I	
MO	10:00-11:00	SMD [ABG]	MS-META [AAS]	MOQ [KSM]	TOM - I [PGK]	TOM - II [YGP]	DOM [FBS]	DOM [UNK]	H&P [PRN]	
	11:00-12:00	EEE [YRS]	SM [VMG]	DME - I [NM]	MOQ [DSM]	TMC [HBK]	EL-1 [JCN]	EL-II [SSJ]	EL-II [MA]	
NO	12:00-01:00	Lunch Break								
ND	01:00-02:00	MS-META [AAS]	THERMO [DDS]	TOM - II [PGK]	DME - I [YSD]	MOQ [DSM]	EL-II [SSJ]	CCA [ANP]	DOM [LNK]	
	2:00-03:00	SM [PR]	EEE [PR]	SD [PR]	DME - I [PR]	MOQ [PR]				
AV	03:00-04:00	[SBI]	[YRS]	[SBI]	[NM]	[KSM]				
	04:00-05:00	SN [SBI]	EEE [YRS]	HT [YSG]	HT [KK]	MOQ [DSM]	DOM [FBS]	EL-1 [JCN]	EL-1 [TSK]	
Tues	05:00-06:00	SMD [ABG]	SM [VMG]	MOQ [KSM]	DME - I [YSD]	HT [YSG]	CCA [PBM]	DOM [UNK]	CCA [ANP]	
	06:00-07:00	Lunch Break								
Wed	07:00-08:00	THERMO [RNG]	THERMO [DDS]	TMC [AB]	MOQ [DSM]	DME - I [YSD]	H&P [PPK]	EL-II [SSJ]	DOM [LNK]	
	08:00-09:00	EEE [PR]		HT [PR]	MOQ [PR]	SD [PR]	EL-1 [PR]	H&P [PR]	CCA [PR]	
Thurs	09:00-10:00	THERMO [RNG]	SM [VMG]	HT [R]	TMC [KSM]	DME - I [SBI]	CCA [JCS]	H&P [PRN]	H&P [PBM]	
	10:00-11:00	THERMO [RNG]	[VMG]	HT [YSG]	[HBK]	[YSD]	[PBM]	[PRK]	[PRN]	
Fri	11:00-12:00	MS-META [AAS]	EEE [YRS]	DME - I [NM]	DME - I [YSD]	HT [YSG]	EL-II [SSJ]	EL-1 [JCN]	EL-1 [TSK]	
	12:00-01:00	Lunch Break								
Sat	01:00-02:00	EEE [YRS]	THERMO [DDS]	TOM - II [PRK]	HT [KK]	TMC [HBK]	EL-1 [JCN]	CCA [ANP]	DOM [LNK]	
	2:00-03:00	SMD [ABG]	SM [PR]	TMC [PR]	SD [PR]	TOM - II [YGP]	CCA [PBM]	EL-1 [TSK]	H&P [PRN]	
Sun	03:00-04:00	SM [SBI]	SM [VMG]	DME - I [NM]	DME - I [YSD]	TOM - II [YGP]	DOM [FBS]	EL-1 [JCN]	DOM [LNK]	



12:00-01:00		01:00-02:00		02:00-03:00		03:00-04:00		04:00-05:00		05:00-06:00	
[YSG]		[YSG]		[YSG]		[YSG]		[YSG]		[YSG]	
Lunch Break											
01:00-02:00	EEE [YRS]	MS-META [AAS]	HT [YSG]	HT [TK]	DME-1 [YSD]	EL-II [SSJ]	H&P [PPK]	CCA [ANP]			
2:00-03:00		SMD (PR) [ABG]	MOC (PR) [KSM]	TOM-II (PR) [VGP]	DME-1 (PR) [NM]	DOM (PR) [FBS]					
10:00-11:00	MS-META [AAS]	SMD [SB]	DME-1 [NM]	HT [FK]	HT [YSG]	DOM [FBS]	H&P [PPK]	EL-II [MA]			
11:00-12:00	SM [SBJ]	MS-META [AAS]	TOM-II [PK]	TMC [HBR]	TOM-II [VGP]	EL-I [JCN]	EL-II [SSJ]	EL-I [TSK]			
End as											
Lunch Break											
01:00-02:00	THERMO [RNG]	EEE [YRS]	MOC [KSM]	MOC [DSM]	TMC [HBR]	CCA [PBM]	DOM [LUNK]	H&P [PPN]			
2:00-03:00	GDET (PR) [PRM]	THERMO (PR) [DDSD]	DME-1 (PR) [NM]	VAC (PR) [AB]	HT (PR) [KK]	H&P (PR) [PRN]	DOM (PR) [TSK]	DOM (PR) [LUNK]			
10:00-11:00	SM [SBJ]	SMD [SB]	TMC [AB]	TOM-II [PK]	MOC [DSM]	H&P [PPK]	DOM [LUNK]	CCA [ANP]			
11:00-12:00	MS-META (PR) [AAS]	GDET (PR) [KSM]	HT [YSG]	TMC [HBR]	DME-1 [YSD]		CCA (PR) [PBM]				
Lunch Break											
01:00-02:00	THERMO (PR) [DDSD]	MS-META (PR) [MA]	TOM-II (PR) [VGP]	HT (PR) [KK]	TMC (PR) [AB]						

Prof. U. N. Kolekar  
Time Table In-charge

Prof. R. N. Garad  
H.O.D (MECH)

Dr. Ashok Kasraite  
Principal



Day	Time	Subject	Faculty	Subject	Faculty	Subject	Faculty	Subject	Faculty	Subject	Faculty	Subject	Faculty
Wed	01:00-02:00	EEE [YRS]	MS-META [AAS]	HT [YSG]	HT [KK]	DME-1 [YSD]	EL-II [SSJ]	H&P [PPK]	CCA [ANP]	EL-I [TSK]	EL-II [MA]	EL-I [TSK]	EL-II [TSK]
	2:00-03:00		SMD [PR] [ABG]	MGC (PR) [KSM]	[TON-II (PR) [VGP]	DME-1 (PR) [ENI]	DOM (PR) [HBS]	DOM [PFS]	H&P [PPK]	H&P [PPK]	EL-II [SSJ]	EL-I [SSJ]	EL-II [TSK]
Thu	01:00-02:00	THERMO [RNG]	EEE [YRS]	MOC [KSM]	MOC [DSM]	TMC [HBK]	CCA [PBM]	DOM [UNK]	H&P [PRN]				
	2:00-03:00	GDET (PR) [PRM]	THERMO (PR) [DDP]	DME-1 (PR) [NM]	TMC (PR) [AB]	HT (PR) [EN]	H&P (PR) [PRM]	DOM (PR) [TSK]	DOM (PR) [HDK]				
Fri	01:00-02:00	SM [SB]	SMD [SB]	TMC [AB]	TON-II [PCK]	MOC [DSM]	H&P [PPK]	DOM [UNK]	CCA [ANP]				
	11:00-12:00	MS-META (PR) [AAS]	GDET (PR) [SSM]	HT [YSG]	TMC [HBK]	DME-1 [YSD]		CCA (PR) [PBM]					
Lunch Break													
Sat	01:00-03:00	THERMO (PR) [DDP]	MS-META (PR) [MA]	TOM-II (PR) [VGP]	HT (PR) [KN]	TMC (PR) [AB]							

Prof. U. N. Kolekar  
Time Table In-charge

Prof. R. N. Garad  
H.O.D (MECH)

Dr. Ashok Kasnale  
Principal

H.O.D.  
Dept. of Mechanical Engg.  
Dr. D. Y. Patil School of Engg, Lohgaon, Pune





**EMPOWERMENT THROUGH ACADEMIC EXCELLENCE**  
**Time Table of Mechanical Department (SEM-III) w. e. f. 1/02/2021**

Practical Time: 2:00 PM - 3:00 PM

Day	TIME	SE - (COSP)	TE - D	TE - E	TE - F	DE - G	BE - H	BE - I
MO	10:00-11:00	SM(SB)	RAC (KK)	DME-II(PGK)	RAC(DDS)	MSD (VMG)	EE (YSG)	EE(DDS)
	11:00-12:00	MS(META(MA))	MP-II(TSK)	RAC (KK)	MP-II(ABG)	EE (YSG)	MSD(PPK)	AMP(PRN)
TU	10:00-11:00	THRM(O/RNG)	DME-II(YSD)	MP-II(TSK)	DME-II(VGP)	IE(DDSM)	IE(MA)	IE(PBM)
	11:00-12:00	EEE(AB)	NMO(SB)	RAC(PRN)	NMO(NM)	IE(DSM)	IE(MA)	IE(PBM)
WED	10:00-11:00	MS(META(MA))	DME-II(YSD)	RAC (KK)	MP-II(ABG)	EE (YSG)	AMP(PRN)	MSD (UNK)
	11:00-12:00	SM(SB)	MP-II(TSK)	DME-II(PGK)	DME-II(VGP)	MSD (VMG)	EE (YSG)	EE(DDS)
THU	10:00-11:00	SMD(ABG)	RAC (KK)	MP-II(TSK)	RAC(DDS)	AMP(PNP)	MSD(PPK)	AMP(PRN)
	11:00-12:00	EEE(AB)	DME-II(YSD)	NMO(NM)	RAC(PRN)	EE(YSG)	MSD(PPK)	EE(TSK)
FRI	10:00-11:00	SM(SB)	MTX(KSM)	NMO(SB)	MTX(SSJ)	IE(DSM)	IE(MA)	AMP(PRN)
	11:00-12:00	MS(META(MA))	NMO(SB)	RAC(KK)	NMO(NM)	AMP(PNP)	AMP(PRN)	IE(PBM)
SAT	01:00-02:00	SMD(ABG)	RAC (KK)	MP-II(TSK)	RAC(DDS)	MSD (VMG)	MSD(PPK)	MSD (UNK)
	2:00-03:00	EEE(AB)	MTX(KSM)	MTX(SSJ)	DME-II(VGP)	MSD(VMG)	EE(YSG)	MSD (UNK)
SUN	10:00-11:00	SM(SB)	DME-II(YSD)	RAC (KK)	DME-II(VGP)	IE(DSM)	IE(MA)	MSD (UNK)
	11:00-12:00	THRM(O/RNG)	MTX(KSM)	NMO(SB)	MTX(SSJ)	AMP(PNP)	EE (YSG)	IE(PBM)
Lunch Break								





2:00-3:30	0	THEM(O/RNG)	PAC(RK)	DME-II(VGP)	MTX(SS)					
10:00-11:00	00	THEM(O/RNG)	MP-II(TSK)	DME-II(PGN)	MP-II(ABG)	M50 (WVG)	M5D(PRK)	M5D (UNK)		
11:00-12:00	00	SM(SB)	NMO(SB)	MTX(KSM)	NMO(NM)	EE (YSG)	AMP(PRN)	EI(DDS)		
12:00-01:00	00									
01:00-02:00	00	MS-META(MA)	MTX(KSM)	NMO(SB)	MTX(SS)					
2:00-03:00	00	EDE(AB)								
10:00-11:00	00		DME-II(YSD)	NMO(SB)	DME-II(VGP)					
11:00-12:00	00		RAC(RK)	MTX(KSM)	NMO(NM)					
12:00-01:00	00									
01:00-02:00	00									
2:00-03:00	00		NMO(SB)	DME-II(PGN)	RAC(DDS)					

Prof. U. N. Kolekar  
Time Table In-charge

Prof. R. N. Garad  
H.O.D (Mech)

Dr. Ashok Kasnale  
Principal



*[Handwritten signature]*

*[Handwritten signature]*

*[Handwritten signature]*

Lunch Break

Dr. D. Y. Patil Technical Campus

# **Dr. D. Y. Patil School of Engineering**

Dr. D. Y. Patil Knowledge City, Charholi (Bk), Lohegaon, Pune – 412 105

## 2) Workload Distribution



## Dr. D. Y. Patil School of Engineering

Dr. D. Y. Patil Knowledge City, Charholi (Bk), Lohegaon, Pune – 412 105

Website: www.dypic.in,

Contact No.:020-6707 7926

### Department of Electronics and Telecommunication Engineering

#### LOAD DISTRIBUTION

A. Y. 2020-21

Semester-II

Sr. No.	Name of the Faculty	Class & DIV	Subject	Theory/Week	Practical / Tutorial	Total/Week	Sign
1.	Dr. S. M. Koli (SMK) (Professor & HoD)	TE	DC	2		4	
		BE	CNS	2			
2.	Dr. Rashmi Mahajan (RM)	TE	MC	2		4	
		BE	VLSI	2			
3.	Dr. B. K. Shiragapur (BKS)	SE	DC	2		4	
		BE	EPD	2			
4.	Prof. Riyaj Kazi (RLK)	SE	EC	1		3	
		TE	ESD	2			
5.	Prof. Swati Khawate (SK)	TE	EM	2		4	
		BE	RMT	2			
6.	Prof. Nishikant Surwade	TE	DSP	2		4	
		BE	DIVP	2			
7.	Prof. P. Khairnar (PK)	SE(Comp)	DELD	2		2	
8.	Prof. Kundan Saraf (KS)	SE	Elec. Circuits	2		2	
		SE(Mech)	EEE	2			
9.	Dr. Saniya Ansari (SA)	TE	MECH	2		2	
10	Prof. Ashwini Pandagale	SE	DS	2		2	
11	Dr. Khairnar S. M.	SE	EM-III	2		2	

  
Dr. Sanjay M. Koli  
HoD (E&TC)

  
Dr. Ashok Kasnale  
Principal



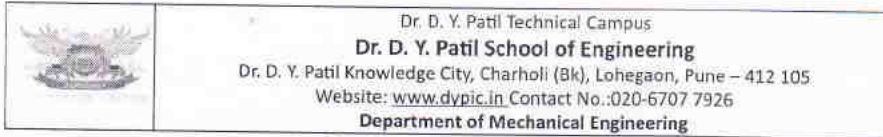

Load distribution

Date: 29/10/2020

A.Y.: 2020 - 2021

Semester: II

SR. No.	Name of the Faculty	Class & DIV	Subject	Theory	Practical/ Tutorial	Load With Project
1	Prof. Rohit N. Garad	SE - A	THERMO	3	-	6
		SE - C		3		
2	Dr. F. B. Sayyad	BE - G	DOM	4	1	5
3	Prof. Prashant G. Karajagi	TE - D	TOM-II	3	-	6
		TE - E	TOM-II	3	-	
4	Prof. Santosh B. Jadhav	SE - A	SM	4	1	9
		SE - C		4		
5	Dr. Dileep S. More	TE - E	MQC	3	-	6
		TE - F	MQC	3	-	
6	Prof. Amol B. Galkwad	SE - A	SMD	3	1	8
		SE - B	SMD	-	1	
		SE - C	SMD	3	-	
7	Prof. Amol N. Patil	BE - H	CCA	3	-	6
		BE - I	CCA	3	-	
8	Prof. Vikram M. Ghule	SE - B	SM	4	1	6
		SE - C	SM	-	1	
9	Prof. Yogesh S. Gandai	TE - D	HT	4	-	8
		TE - F	HT	4	-	
10	Prof. Paresh P. Khairnar	BE - G	H&P	3	-	6
		BE - H	H&P	3	-	
11	Prof. Umaji N. Kolekar	BE - I	DOM	4	-	9
		BE - H	DOM	4	-	
		BE - G	DOM	-	1	
12	Prof. Pooja Nawathe	BE - I	H&P	3	1	6
		BE - H	H&P	-	1	
		BE - G	H&P	-	1	
13	Prof. Sechin S. Jadhav	BE - G	EL-II (AUTO)	3	-	6

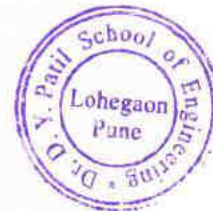
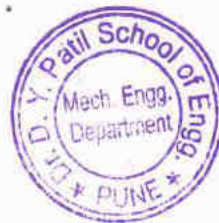

		BE - H	EL-II (AUTO)	3		
14	Prof. Parag B. Marathe	BE - G	CCA	3	1	7
		BE - I	CCA	-	1	
		BE - I	CCA	-	1	
		SE	GD&T	-	1	
15	Prof. Yogesh S. Danekar	TE - E	DME - I	4	-	8
		TE - F	DME - I	4	-	
16	Prof. Jagruti Nimgulkar	BE - G	EL-I (HVAC)	3	1	7
		BE - H	EL-I (HVAC)	3		
17	Prof. Tejaswini S. Kulkarni	BE - H	EL-I (HVAC)		1	6
		BE - I	EL-I (HVAC)	3	1	
		BE - H	DOM	-	1	
18	Prof. Vinod G. Patil	TE - F	TOM - II	3	1	6
		TE - E	TOM - II		1	
		TE - D	TOM - II		1	
19	Prof. Dipak Shelke	SE - B	THERMO	3	1	6
		SE - A	THERMO	-	1	
		SE - C	THERMO	-	1	
20	Prof. Amit A. Shinde	SE - A	MS-META	3	1	7
		SE - B	MS-META	3		
21	Prof. Sandeep Bhaskar	SE - B	SMD	3		7
		SE - C	SMD		1	
		TE - D, E, F	SD	-	3	
22	Ms. Himani Kadam	TE - E	TMC	3	-	6
		TE - F	TMC	3	-	
23	Prof. Mohd. Imran Ansari	SE - B	MS-META		1	8
		SE - B	MS-META	3	1	
		BE - I	EL-II (AUTO)	3	-	
24	Prof. Kunal Marathe	TE - D	MQC	3	1	7
		TE - F, E	MQC	-	2	
		SE - B	GD&T	-	1	



25	Prof. ANIL BAVCHE	TE - D	TMC	3	1	6
		TE - F, E	TMC		2	
26	Prof. Nithin Mare	TE - D	DME-I	4	1	7
		TE - E, F	DME-I		2	
27	Prof. KUNDAN K.	TE - E	HT	4	1	7
		TE - F, D	HT		2	

  
H.O.D. (Mechanical)

  
Principal

H. O. D.  
Dept. of Mechanical Engg.  
Dr. D. Y. Patil School of Engg., Lohegaon, Pune



	Dr. D. Y. Patil Technical Campus <b>Dr. D. Y. Patil School of Engineering</b> Dr. D. Y. Patil Knowledge City, Charholi (Bk), Lohegaon, Pune - 412 105 Website: <a href="http://www.dypic.in">www.dypic.in</a> Contact No.: 020-6707 7926 <b>Department of Mechanical Engineering</b>
---	--

Load distribution

Date: 02/01/2021

A.Y.: 2020 - 2021

Semester: II

SR. No.	Name of the Faculty	Class & DIV	Subject	Theory	Practical/ Tutorial	Load With Project	Load Without Project
1	Prof. Rohit N. Garad	SE - A	ATD	3	-	13	9
		A1,A2,A3	ATD		6		
		BE	Project	-	4		
2	Dr. F. B. Sayyad	SE-A	KOM	3	-	13	9
		A1,A2,A3	KOM		6		
		BE	Project	-	4		
3	Prof. Prashant G. Karajagi	TE - E	DME-II	4		15	11
		E1	DME-II		2		
		BE	Project	-	4		
		ME	ASA	5			
4	Prof. Santosh B. Jadhav	SE - C	KOM	3		17	13
		C1,C2,C3	KOM		6		
		E2,E3	DME-II		4		
		BE	Project	-	4		
5	Dr. Dileep S. More	BE-G,G1,GG2, G3	IE	3	6	17	13
		ME	RM	4			
		BE	Project	-	4		
6	Prof. Amol B. Gaikwad	TE-F	MP-II	3		18	14
		C2,C1	PBL		6		
		ME	ELECTIVE-I	5			
		BE	Project	-	4		
7	Prof. Amol N. Patil	BE - G	AMP	3		18	14
		C1	PBL		2		
		ME	MSMBM	4			
		ME	LAB PRACTICE		5		
		BE	Project	-	4		
8	Prof. Vikram M. Ghule	BE-G,G1,G2,G 3	MSD	4	6	19	15
		BE-ELECTIVE-I V		3			
		C3	FM		2		
		BE	Project	-	4		

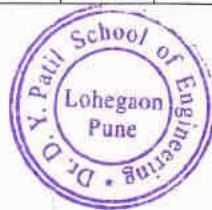

9	Prof. Yogesh S. Gandal	BE-G,G1,G2,G3	EE	3	6	20	16
		BE-H,H1,H2	EE	3	4		
		BE	Project	-	4		
10	Prof. Paresh P. Khairnar	BE - H,H1,H2,H3	MSD	4	6	18	14
		A3	PBL		4		
		BE	Project	-	4		
11	Prof. Umaji N. Kolekar	BE - I,I1,I2,I3	MSD	4	6	20	16
		D1,D2,F3	SEMINAR		6		
		BE	Project	-	4		
12	Prof. Pooja R. Nawathe	BE H	AMP	3		20	16
		BE I	AMP	3			
		F1,F2,F3	RAC		6		
		E1,E2	RAC	-	4		
		BE	Project	-	4		
13	Prof. Sachin S. Jadhav	TE-F,F1,F2,F3	MTX	3	6	19	15
		E2,E3	MIX		4		
		D3	SEMINAR		2		
		BE	Project	-	4		
14	Prof. Parag B. Marathe	BE - I,I1,I2,I3	IE	3	6	19	15
		H1	IE	-	2		
		TE-E & F	MS-II		4		
		BE	Project	-	4		
15	Prof. Yogesh S. Danekar	TE - D,D1,D2	DME - II	4	4	20	16
		E1,E2,F1,F2	SEMINAR		8		
		BE	Project	-	4		
16	Prof. Kundan K. Kolambe	TE-D ,D1,D2,D3	RAC	4	6	20	16
		TE-E & E3	RAC	4	2		
		BE	Project	-	4		
17	Prof. Tejaswini S. Kulkarni	TE D	MP-II	3		20	16
		TE E	MP-II	3			
		H3,I1,I2,I3	EE		8		
		TE-D	MS-II		2		
		BE	Project	-	4		
18	Prof. Vinod G. Patil	TE - F,F1,F2,F3	DME-II	4	6	21	17
		D3	DME-II		2		
		BE	ELECTIVE-III	3	2		
		BE	Project	-	4		
19	Prof. Dipak D. Shelke	C1,C2,C3	ATD		6	18	14
		BE-I	EE	4			

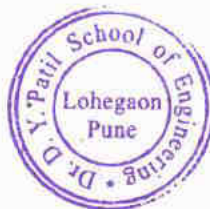



		TE-F	RAC	4			
		BE	Project	-	4		
20	Prof. Amit A. Shinde	SE-A	MP	3		18	14
		SE-C	MP	3			
		A1,A2	PBL		8		
		BE	Project	-	4		
21	Prof. Sandeep Bhaskar	TE-D,D1,D2,D3	NMO	4	6	20	16
		TE-E,E1	NMO	4	2		
		BE	Project	-	4		
22	Prof. Mohd. Imran Ansari	SE-C	ATD	3		18	14
		C3	PBL		4		
		E3	SEMINAR		2		
		BE H,H2	IE	3	2		
		BE	Project	-	4		
23	Prof. Kunal S. Marathe	TE-D,D1,D2,D3	MTX	3	6	18	14
		TE-E,E1	MTX	3	2		
		BE	Project	-	4		
24	Prof. Anil Bavche	SE-A, A1,A2,A3	FM	3	6	20	16
		SE-C, C1,C2	FM	3	4		
		BE	Project	-	4		
25	Prof. Nitin More	TE-F,F1,F2,F3	NMO	4	6	20	16
		E2,E3	NMO		4		
		BE-H3	IE		2		
		BE	Project	-	4		

H.O.D. (Mechanical)

Principal

H.O.D.  
Dept. of Mechanical Engg.  
Dr. D. Y. Patil School of Engg., Lohegaon, Pune





Dr. D. Y. Patil Group of Institutions' Technical Campus  
**Dr. D. Y. PATIL SCHOOL OF ENGINEERING**  
 Dr. D. Y. Patil Knowledge City, Charholi Bk., Via. Lohagaon, Pune - 412 105.  
 Department of Engineering Sciences (FE)

**FE Faculty Work load Distribution Details A.Y.2020-21 (Sem-I)**

Sr No	Sub	Faculty Initial	Name of the Faculty	Div (TH)	Hours	Subjects		Class	Other Subjects		Total
						PR/TU	Batch		Hours	TH	
1		SMK	Dr. S.M. Khairnar	A,B	6	A1,A2,A3,B1					10
2	M-I/ III	RDK	Dr. Rahul Kumar Katkade	C,D	6	B2,B3,C1,C2,C3,D1,D2,D3	8	SE -Mech(A)	1		17
								SE-Comp (A, B)	2		
3	M-I/ III	BBG	Mr. Bhagwat Gidhad					Poly.	4	1	18
								Project			
								SE -Mech(A)	3		
								SE Mech(B)	3	1	
4								SE-Comp (A, B)	6		14
7	M-I	SVR	Dr. Shobha Ruppnar	C,D	8	C1,C2,C3	6	POLY	2	6	14
								ES-1	4		
8	M-I	NHU	Dr. Nitraj Jadhav			D1,D2,D3	6	POLY	2	6	18
								ES-1	4		
9	BEE	RSG	Ms. Rohini Gaddgil	A,B	6	A1,A2,A3,B1,B2,B3	12				18
10	BXE	PK	Ms. Prajakta Khairnar	C,D	6	C1,C2,C3,D1,D2,D3	12				18
11	SME	VDT	Mr. Vinod D. Tirpude	A,B	6	A1,A2,A3,B1,B2,B3	12				18
12		AA	Mr. Awes Ansari	C,D	6	C1,C2,C3,D1,D2,D3	12				18
13	PPS	PS	Mr. Prashant Sagre	A,B	6	A1,A2,A3,B1,B2,B3	12				18
14	EM	PG	Mr. Prasad Gayke	C,D	6	C1,C2,C3,D1,D2,D3	12				18
15	WS	SBM	Mr. Shashikant B. More	All Div	0	A1,A2,A3,B1,B2,B3 C1,C2,C3,D1,D2,D3	24				24



*(Signature)*  
 Dr. S.M. Khairnar  
 Head of Dept(FE)

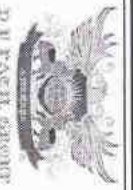

Dr. D. Y. Patil Group of Institutions' Technical Campus  
**Dr. D. Y. PATIL SCHOOL OF ENGINEERING**  
 Dr. D. Y. Patil Knowledge City, Charnoli Bk., Via. Lohegaon, Pune - 412 105.  
 Department of Engineering Sciences (FE)

**FE Faculty Work load Distribution Details A.Y.2020-21 (Sem-I)**

Sr No	Sub	Faculty Initial	Name of the Faculty	Subjects			Other Subjects			Total			
				Div (THD)	Hours	PR/TU	Batch	Hours	Class		TH	PR/TU	
1		SMK	Dr. S.M. Khairnar	A,B	6		A1,A2,A3,B1	4				10	
2		RDK	Dr. Rahul Kumar Karkade	C,D	6		B2,B3,C1,C2,C3,D1,D2,D3	8	SE-Mech(A) SE-Comp (A, B)	1 2		17	
3	M-I/III	BBG	Mr. Bhagwat Gidhad						Poly. Project	4	1		18
4									SE-Mech(A) SE Mech(B) SE-Comp (A, B)	3 3 6	1		14
5	EP	SC	Ms. Soma Cynric	A,B	8		A1,A2,A3	6					14
6		PS	Mr. Amit Uphad				B1,B2,B3	6	POLY	2	6		14
7		SVR	Dr. Shobha Rupnar	C,D	8		C1,C2,C3	6	ES-1	4			18
8	EC	NHI	Dr. Niraj Jadhav				D1,D2,D3	6	POLY ES-1	2 4	6		18
9	BEE	RSG	Ms. Rohini Gadgil	A,B	6		A1,A2,A3,B1,B2,B3	12					18
10	BXE	PK	Ms. Prajakta Khairnar	C,D	6		C1,C2,C3,D1,D2,D3	12					18
11	SME	VDT	Mr. Vinod D. Tirpude	A,B	6		A1,A2,A3,B1,B2,B3	12					18
12		AA	Mr. Awes Ansari	C,D	6		C1,C2,C3,D1,D2,D3	12					18
13	PPS	PS	Mr. Prashant Sagre	A,B	6		A1,A2,A3,B1,B2,B3	12					18
14	EM	PG	Mr. Prasad Gayke	C,D	6		C1,C2,C3,D1,D2,D3	12					18
15	WS	SBM	Mr. Shashikant B. More	All Div	0		A1,A2,A3,B1,B2,B3 C1,C2,C3,D1,D2,D3	24					24



*Dr. S M Khairnar*  
 Dr. S M Khairnar  
 Head of Dept. (FE)



Dr. D. Y. Patil Group of Institutions' Technical Campus  
**Dr. D. Y. PATIL SCHOOL OF ENGINEERING**  
 Dr. D. Y. Patil Knowledge City, Charkholi Bk., Via. Lohagaon, Pune – 412 105.  
 Department of Engineering Sciences (FE)

**FE Faculty Work load Distribution Details A. Y. 2020-21 (Sem-I)**

Sr No	Sub	Faculty Initial	Name of the Faculty	Subjects			Other Subjects			Total
				Div (TH)	Hours	PR/TU	Hours	Class	TH	
1		SMK	Dr. S.M. Khairnar	A,B	6	A1,A2,A3,B1	4			10
2		RDK	Dr. Rahulkumar Karkade	C,D	6	B2,B3,C1,C2,C3,D1,D2,D3	8	SE -Mech(A) SE-Comp (A, B)	1 2	17
3	M-I/ III	BBG	Mr. Bhagwat Gidhad					Poly. Project SE -Mech(A) SE Mech(B) SE-Comp (A, B)	4 3 3 1 6	18
4										14
5	EP	SC	Ms. Soma Cyriac	A,B	8	A1,A2,A3	6	POLY	2	14
6		PS	Mr. Amit Uplhad			B1,B2,B3	6	ES-1	4	18
7		SVR	Dr. Shebha Rupnar	C,D	8	C1,C2,C3	6	POLY	2	18
8	EC	NHJ	Dr. Niraj Jadhav			D1,D2,D3	6	ES-1	4	18
9	BEE	RSG	Ms. Rohini Gadgil	A,B	6	A1,A2,A3,B1,B2,B3	12			18
10	BXE	PK	Ms. Prajakta Khairnar	C,D	6	C1,C2,C3,D1,D2,D3	12			18
11	SME	VDT	Mr. Vinod D. Tirpude	A,B	6	A1,A2,A3,B1,B2,B3	12			18
12		AA	Mr. Awes Ansari	C,D	6	C1,C2,C3,D1,D2,D3	12			18
13	PPS	PS	Mr. Prashant Sagre	A,B	6	A1,A2,A3,B1,B2,B3	12			18
14	EM	PG	Mr. Prasad Gayke	C,D	6	C1,C2,C3,D1,D2,D3	12			18
15	WS	SBM	Mr. Shashikant B. More	All Div	0	A1,A2,A3,B1,B2,B3 C1,C2,C3,D1,D2,D3	24			24



*Dr. S M Khairnar*

Head of Dept. (FE)

Dr. D. Y. Patil Technical Campus

# **Dr. D. Y. Patil School of Engineering**

Dr. D. Y. Patil Knowledge City, Charholi (Bk), Lohegaon, Pune – 412 105

## **3) Leave Record And Adjustments**

# Leave Register

3

Dr D Y Patil

Dr D Y Patil

(Approved by AICTE, Govt. of Maharashtra)

Dr D Y Patil Knowledge Centre

Name

Prof. Ramesh K. Khairnar

Address

Designation & Dept.

Sr	Type of Leave	From	To	Total availed Leave	Signature of Concerned
1	Personal	18/3/21	18/3/21	1/2	R
1	Personal (C.L)	19/7/21	19/7/21	1/2	R
	Personal C.L	20/8/21	20/8/21	1	R
	O.D.	8/9/21	8/9/21	1/2	R
	Medical	17/9/21	20/9/21	04	R
	Medical	29/9/21	1/10/21	03	R
	Personal (CL)	23/11/21	23/11/21	1/2	R

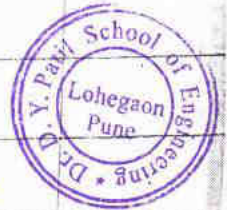

# Leave Register

Dr D Y Patil  
 (Approved by AICTE, Govt. of Maharashtra)  
 Dr D Y Patil Knowledge

Name

Prof. Jyeshh Dhanekar

Address

Designation & Dept.

Sr	Type of Leave	From	To	Total availed Leave	Conceded
01	CL	15/02/21	15/02/21	01	✓
02	CL	12/08/21	12/08/21	01	✓
03	CL	30/08/21	30/08/21	01	✓
04	CL	13/09/21	13/09/21	01	✓
05	CL	21/10/21	21/10/21	01	✓



# Leave Register

Dr D Y Patil  
Dr D Y Patil  
(Approved by AICTE, Govt. of India)  
Dr D Y Patil Knowledge

Name : Dr. Dilip Satappa More  
Address :  
Designation & Dept. :

Sr	Type of Leave	From	To	Total availed Leave	Signature
1.	CL	26/2/21	26/2	01	[Signature]
2.	C-L.	03/08/21	03/08/21	01	[Signature]
3.	M.L.	17/8/21	19/8/21	03	[Signature]
4.	M.L.	18/10/21	25/10/21	07	[Signature]

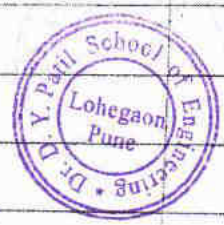



# Leave Register

Dr D Y Patil  
 (Approved by AICTE, Govt of India)  
 Dr D Y Patil Knowledge

Name

*Prof. Jyeshth Shankar Grandol*

Address

Designation & Dept

Sr	Type of Leave	From	To	Total availed Leave	Signature
1	CL	01-March-21	01 March 2021	0.5 day (1/2)	<i>[Signature]</i>
2	ML	02-March-21	14/03/2021	13 days	<i>[Signature]</i>
3	DD	18/03/21	18/2/21	01 day	<i>[Signature]</i>
4	CL	29/07/21	30/07/21	02 days	<i>[Signature]</i>
5	ML	03/08/21	05/08/21	03 day	<i>[Signature]</i>
6	ML	23/8/21	25/8/21	03 days	<i>[Signature]</i>
7	CL	02/9/21	2/9/21	01 day	<i>[Signature]</i>
8	ML	06/9/21	08/9/21	03 day	<i>[Signature]</i>
9	CL	08/9/21	28/9/21	01 day	<i>[Signature]</i>
10	ML	11/10/21	13/10/21	03 day	<i>[Signature]</i>
11	CL	25/10/21	-	1/2 day	<i>[Signature]</i>
12	ML	9/11/21	11/11/21	03 days	<i>[Signature]</i>



# Leave Register

Dr. D. Y. Patil  
 Dr. D. Y. Patil  
 (Approved by AIC TE Genl. Insp.)  
 Dr. D. Y. Patil Knowledge

Name: **Dr. Dilip Sankappa More**

Address: \_\_\_\_\_

Designation & Dept: \_\_\_\_\_

Sr	Type of Leave	From	To	Total availed Leave	Sign Concern
1	CL	26/12/21	26/12	01	
2	C.L.	03/08/21	03/08/21	01	
3	M.L.	17/8/21	19/8/21	03	
4	M.L.	18/10/21	25/10/21	07.08	



Dr. D. Y. Patil Technical Campus

# **Dr. D. Y. Patil School of Engineering**

Dr. D. Y. Patil Knowledge City, Charholi (Bk), Lohegaon, Pune – 412 105

## 4) Planning For the Practical Session

Vision: - "EMPOWERMENT THROUGH ACADEMIC EXCELLENCE"

<b>Dr. D. Y. Patil School of Engineering, Pune -412 105</b>		
<b>Department of Mechanical Engineering</b>		
<b>Class: B.E (Batch: G1)</b>	<b>Heating, Ventilation, Air Conditioning &amp; Refrigeration</b>	<b>Sem : VII</b>
<b>Practical Plan</b>		

Practical hours per Week : 02

Subject In-charge : Prof. Jagruti C. Nimgulkar

**Notes :**

Any three practicals from the list should be conducted in practical sessions.

Sr. No.	Practical No.	Planned Date	BROAD TOPICS TO BE COVERED	Name of Experiment	Actual Date of Conduction	Remark
1.	1	25/06	Air Conditioning system	Performance Simulation of Central Air-conditioning plant using Newton Raphson Method		
2.	2	16/07	Cooling tower	Performance analysis of Counter flow or cross flow cooling tower		
3.	3	20/08	Load Calculations	Building heat load simulation using suitable software (Trace 700, Energy plus etc.)		
4.	4	10/09	Pipeline Design	Design of cold storage with process layout.		

Prof. Jagruti C. Nimgulkar  
Subject In-charge



**Mission:-**

- M1:** Imparting Value Base Education
- M2:** Integrating Engineering and Industry
- M3:** Enhancing Employability and Entrepreneurship
- M4:** Developing Research Culture

1.1.1-4



Dr. D. Y. Patil Group of Institutions' Technical Campus  
**Dr. D. Y. PATIL SCHOOL OF ENGINEERING**  
 Dr. D. Y. Patil Knowledge City, Charholi Bk., Via. Lohegaon, Pune - 412  
 105.  
 Department of Computer Engineering



### Subject Data Structure and Algorithm Practical Plan

**Subject Code: 210256**

**SEM II - AY 2020-2021**

Sr. No.	Name of Experiment	Planned Date of Conduction
<b>Group A</b>		
1	Consider telephone book database of N clients. Make use of a hash table implementation to quickly look up client's telephone number. Make use of two collision handling techniques and compare them using number of comparisons required to find a set of telephone numbers.	22/03/2021
2	Implement all the functions of a dictionary (ADT) using hashing and handle collisions using chaining with / without replacement. Data: Set of (key, value) pairs, Keys are mapped to values, Keys must be comparable, Keys must be unique Standard Operations: Insert(key, value), Find(key), Delete(key).	24/03/2021
3	To create ADT that implement the "set" concept. <ol style="list-style-type: none"> <li>Add (newElement) -Place a value into the set</li> <li>Remove (element) Remove the value</li> <li>Contains (element) Return true if element is in collection</li> <li>Size () Return number of values in collection Iterator () Return an iterator used to loop over collection</li> <li>Intersection of two sets</li> <li>Union of two sets</li> <li>Difference between two sets</li> <li>h. Subset</li> </ol>	31/03/2021
<b>Group B</b>		
4	A book consists of chapters, chapters consist of sections and sections consist of subsections. Construct a tree and print the nodes. Find the time and space requirements of your method.	05/04/2021
5	Beginning with an empty binary search tree, Construct binary search tree by inserting the values in the order given. After constructing a binary tree - <ol style="list-style-type: none"> <li>Insert new node</li> <li>ii. Find number of nodes in longest path from root</li> <li>iii. Minimum data value found in the tree</li> <li>iv. Change a tree so that the roles of the left and right pointers are swapped at every node</li> <li>v. Search a value</li> </ol>	07/04/2021
6	Construct an expression tree from the given prefix expression eg. +-a*bc/def and traverse it using postorder traversal (non recursive) and then delete the entire tree.	14/04/2021

Group C		
7	Represent a given graph using adjacency matrix/list to perform DFS and using adjacency list to perform BFS. Use the map of the area around the college as the graph. Identify the prominent land marks as nodes and perform DFS and BFS on that.	19/04/2021
8	There are flight paths between cities. If there is a flight between city A and city B then there is an edge between the cities. The cost of the edge can be the time that flight take to reach city B from A, or the amount of fuel used for the journey. Represent this as a graph. The node can be represented by airport name or name of the city. Use adjacency list representation of the graph or use adjacency matrix representation of the graph. Check whether the graph is connected or not. Justify the storage representation used.	28/04/2021
Group D		
9	Given sequence $k = k_1 < k_2 < \dots < k_n$ of $n$ sorted keys, with a search probability $p_i$ for each key $k_i$ . Build the Binary search tree that has the least search cost given the access probability for each key?	03/05/2021
10	A Dictionary stores keywords & its meanings. Provide facility for adding new keywords, deleting keywords, updating values of any entry. Provide facility to display whole data sorted in ascending/ Descending order. Also find how many maximum comparisons may require for finding any keyword. Use Height balance tree and find the complexity for finding a keyword.	07/05/2021
Group E		
11	Consider a scenario for Hospital to cater services to different kinds of patients as Serious (top priority), b) non-serious (medium priority), c) General Checkup (Least priority). Implement the priority queue to cater services to the patients.	14/05/2021
12	Implement the Heap/Shell sort algorithm implemented in Java demonstrating heap/shell data structure with modularity of programming language	19/05/2021
Group F		
13	Company maintains employee information as employee ID, name, designation and salary. Allow user to add, delete information of employee. Display information of particular employee. If employee does not exist an appropriate message is displayed. If it is, then the system displays the employee details. Use index sequential file to maintain the data.	24/05/2021



*mali* *Prashant*  
Prof. Nilesh Mali & Prof. Prashant Mandale

Subject In-Charge

Dr. D. Y. Patil Technical Campus

# **Dr. D. Y. Patil School of Engineering**

Dr. D. Y. Patil Knowledge City, Charholi (Bk), Lohegaon, Pune – 412 105

## 5) Practical Manuals

Dr. D. Y. Patil Technical Campus

# Dr. D. Y. Patil School of Engineering

Dr. D. Y. Patil Knowledge City, Charholi (Bk), Lohegaon, Pune – 412 105

**Department of Computer Engineering**



**Data Structures and Algorithms**

(S. E. Computer) 2019 Course

# LABORATORY MANUAL

Prepared By  
**Prof. Nilesh Mali**  
(Asst. Professor)

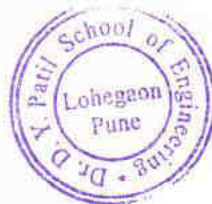

Approved By  
**Dr. Pankaj Agarkar**  
(H. O. D.)



## ADVANCED DATA STRUCTURES LABORATORY

### List of Assignments

#### Group A:

1. Beginning with an empty binary search tree, Construct binary search tree by inserting the values in the order given. After constructing a binary tree -
  - i. Insert new node
  - ii. Find number of nodes in longest path
  - iii. Minimum data value found in the tree
  - iv. Change a tree so that the roles of the left and right pointers are swapped at every node
  - v. Search a value
2. Convert given binary tree into threaded binary tree. Analyze time and space complexity of the algorithm.

#### Group B:

3. Write a function to get the number of vertices in an undirected graph and its edges. You may assume that no edge is input twice.
  - i. Use adjacency list representation of the graph and find runtime of the function
  - ii. Use adjacency matrix representation of the graph and find runtime of the function
4. You have a business with several offices; you want to lease phone lines to connect them up with each other; and the phone company charges different amounts of money to connect different pairs of cities. You want a set of lines that connects all your offices with a minimum total cost. Solve the problem by suggesting appropriate data structures.

#### Group C:

5. Consider telephone book database of N clients. Make use of a hash table implementation to quickly look up client's telephone number.
6. Implement all the functions of a dictionary (ADT) using hashing.  
Data: Set of (key, value) pairs, Keys are mapped to values, Keys must be comparable, and Keys must be unique  
Standard Operations: Insert (key, value), Find (key), Delete (key)

#### Group D:

7. Given sequence  $k = k_1 < k_2 < \dots < k_n$  of n sorted keys, with a search probability  $p_i$  for each key  $k_i$ . Build the Binary search tree that has the least search cost given the access probability for each key.



8. A Dictionary stores keywords & its meanings. Provide facility for adding new keywords, deleting keywords, updating values of any entry. Provide facility to display whole data sorted in ascending/ Descending order. Also find how many maximum comparisons may require for finding any keyword. Use Height balance tree and find the complexity for finding a keyword.

### **Group E:**

9. Read the marks obtained by students of second year in an online examination of particular subject. Find out maximum and minimum marks obtained in that subject. Use heap data structure. Analyze the algorithm

### **Group F:**

10. Department maintains a student information. The file contains roll number, name, division and address. Allow user to add, delete information of student. Display information of particular employee. If record of student does not exist an appropriate message is displayed. If it is, then the system displays the student details. Use sequential file to maintain the data.

### **Group G:**

11. Any application defining scope of Formal parameter, Global parameter, Local parameter accessing mechanism and also relevance to private, public and protected access. Write a Java program which demonstrates the scope rules of the programming mechanism.
12. Write a Java program which will demonstrate a concept of Interfaces and packages: In this assignment design and use of customized interfaces and packages for a specific application are expected.
13. Write a Java program for the implementation of different data structures using JAVA collection libraries (Standard toolkit library): at least 5 data structures are used to design a Suitable application.



## Assignment 1:

### Problem Statement:

Beginning with an empty binary search tree, Construct binary search tree by inserting the values in the order given. After constructing a binary tree -

- i. Insert new node
- ii. Find number of nodes in longest path
- iii. Minimum data value found in the tree
- iv. Change a tree so that the roles of the left and right pointers are swapped at every node
- v. Search a value

Implementation:

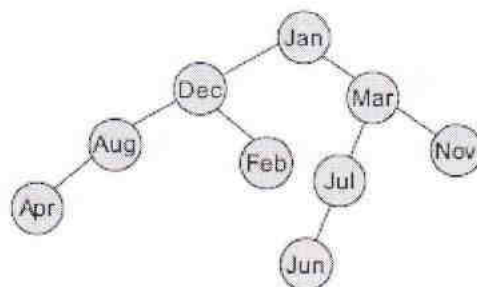
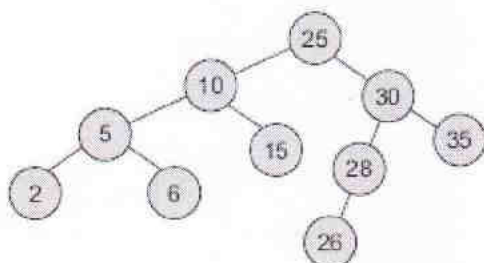

A node in Binary Search tree will be represented as follows:

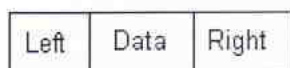

- Declare a structure to represent a node in the binary tree  
Struct BinTree

```

{
    struct BinTree *left;
    char data;
    struct BinTree *right;
};
  
```



- Display a menu with following options:
  1. Recursive Create
  2. Non – recursive create
  3. Insert New Node
  4. Find Height of the tree
  5. Smallest node value in the tree
  6. Mirror Image of the tree
  7. Search Value
  
- Read the choice & switch according to that
- If the choice is 1 or 2 create the root node & then give call to create function
- Otherwise pass the root node as the input parameter to the function

### **Rcreate () function:**

- Main () function has created the root node.
- Display the data for root node.
- Ask user if the new node is to be added to the left.
- If choice is yes
  - Create a new node
  - Read the data for new node
  - Initialize left & right pointers of the new node to NULL.
  - Attach this new node to the left of the root
  - Give recursive call to Rcreate () function with root->left as the new root.
- Display the data for root node.
- Ask user if the new node is to be added to the right.
- If choice is yes
  - Create a new node
  - Read the data for new node
  - Initialize left & right pointers of the new node to NULL.
  - Attach this new node to the right of the root
  - Give recursive call to Rcreate () function with root->right as the new root.
- End of Rcreate()

### **Nrcreate () function**

- Main () function has created the root node.
- Let temp & new node be two node structures  
while(1)

begin

initialize temp to point to Root

```

create a new node
initialize left & right pointer of new node to NULL
accept data for new node
while(1)
begin
    If newnode->data < temp->data
        If temp->left != NULL then
            temp = temp->left
        else
            temp->left = newnode
        break
    If newnode->data > temp->data
        If temp->right != NULL then
            temp = temp->right
        else
            temp->right = newnode
        break
    End
Ask user if more nodes are to be added to the tree
If the 'no' break;
End
➤ End of Nrcreate( )

```

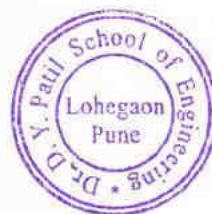

### Find Height of the tree-

There are two conventions to define height of Binary Tree

- 1) Number of nodes on longest path from root to the deepest node.
- 2) Number of edges on longest path from root to the deepest node.

In this post, the first convention is followed. For example, height of the below tree is 3.

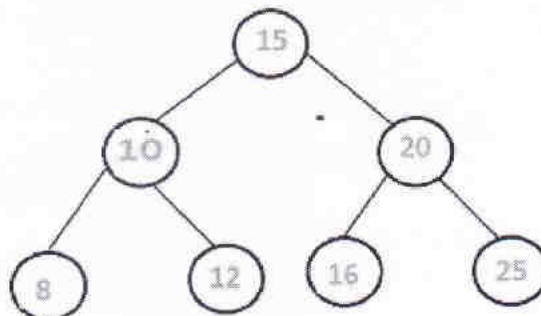

Recursive method to find height of Binary Tree is discussed here. How to find height without recursion? We can use level order traversal to find height without recursion. The idea is to traverse level by level. Whenever move down to a level, increment height by 1 (height is initialized as 0). Count number of nodes at each level; stop traversing when count of nodes at next level is 0.

#### Recursive Function-

```

int btree::nheight(node *root)
{
    int i, j, max=0;
    i=1, j=1;
    if(root!=NULL)
    {
        i=i+nheight(root->left);
        j=j+nheight(root->right);
        if(i>j)
            max=i;
        else
            max=j;
    }
}
  
```

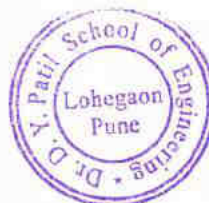

```

    }
    return(max);
}

```

### **Non-recursive function-**

```

int BinaryTree :: TreeHeight(TreeNode *Root)
{
    int heightL, heightR;
    if(Root == Null)
        return 0;
    if(Root->Lchild == Null && Root->Rchild == Null)
        return 0;
    heightL = TreeHeight(Root->Lchild);
    heightR = TreeHeight(Root->Rchild);
    if(heightR > heightL)
        return(heightR + 1);
    return(heightL + 1);
}

```

### **Find the node with minimum value in a Binary Search Tree-**

This is quite simple. Just traverse the node from root to left recursively until left is NULL. The node whose left is NULL is the node with minimum value.



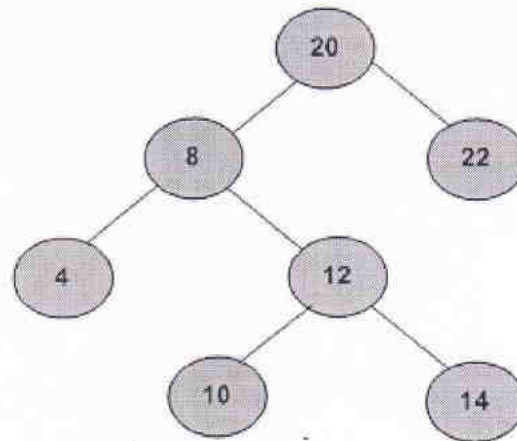

For the above tree, we start with 20, then we move left 8, we keep on moving to left until we see NULL. Since left of 4 is NULL, 4 is the node with minimum value.

In binary search tree, the smallest node is in the left side and the largest node is in the right side. To find the smallest node, the process will check the parent node. In case that the parent node is not empty, if it doesn't have a left child node, the smallest node is the parent node; otherwise the smallest node is its left child node.

#### Find Smallest Node function-( Non-recursive)

```

void btree::smallest(node* root)
{
    node *temp;

    temp=root;

    while(temp->left!=NULL)
        temp=temp->left;

    cout<<"\nMinimum data value="<<temp->data;
}
  
```

#### Find Largest Node function-( Non-recursive)

```

void btree::largest(node* root)
{
    node *temp;
  
```





```
temp=root;
while(temp->right!=NULL)
    temp=temp->right;
cout<<"\nMaximum data value="<<temp->data;
}
```

### Getting Mirror, Replica, or Tree Interchange of Binary Tree

The Mirror() operation finds the mirror of the tree that will interchange all left and right subtrees in a linked binary tree.

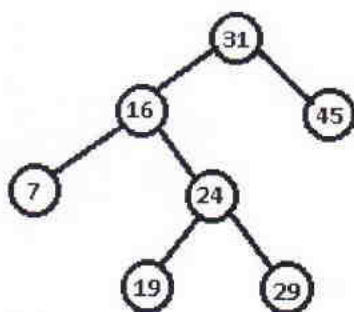

**Original Tree**

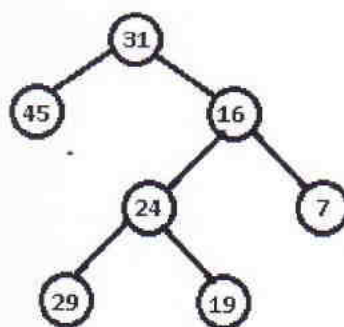

**Mirror Tree**

### Recursive Function

```
void BinaryTree :: Mirror(TreeNode *Root)
```

```
{
```

```
    TreeNode *Tmp;
```

```
    if(Root != Null)
```

```
    {
```

```
        Tmp = Root->Lchild;
```

```
        Root->Lchild = Root->Rchild;
```

```
        Root->Rchild = Tmp;
```



```

        Mirror(Root->Lchild);

        Mirror(Root->Rchild);

    }

}

```

### **Mirror() Function (Non-Recursive) using Queue-**

Initialize a queue of nodes as empty

Initialize a pointer temp = root

Add(temp) to queue

while( queue not empty)

begin

temp = delete

if (temp->left != NULL)

add(temp->left)

if(temp->right != NULL)

add (temp->right)

change = temp->left

temp->Left = temp->right

temp->right = change

end

end



## Searching for a Key-

To search for a target key, we first compare it with the key at the root of the tree. If it is the same, then the algorithm ends. If it is less than the key at the root, search for the target key in the left subtree, else search in the right subtree. Let us, for example, search for the key 'Saurabh' in following Figure

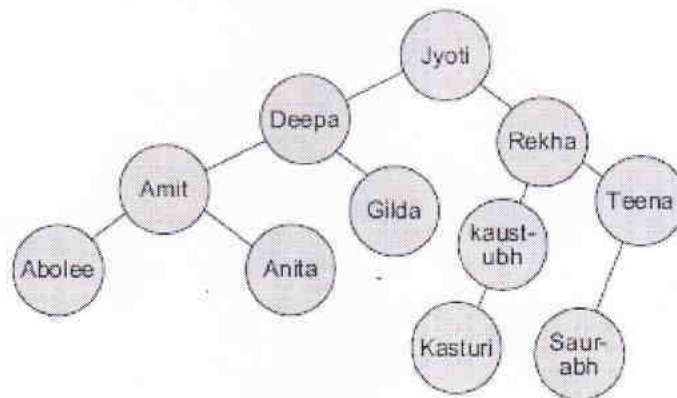

We first compare 'Saurabh' with the key of the root, 'Jyoti'. Since 'Saurabh' comes after 'Jyoti' in alphabetical order, we move to the right side and next compare it with the key 'Rekha'. Since 'Saurabh' comes after 'Rekha', we move to the right again and compare with 'Teena'. Since 'Saurabh' comes before 'Teena', we move to the left. Now the question is to identify what event will be the terminating condition for the search. The solution is if we find the key, the function finishes successfully. If not, we continue searching until we hit an empty subtree.

Program Code shows the implementation of search () function, both nonrecursive and recursive implementations.

### Non-recursive-

```
TreeNode *BSTree :: Search(int Key)
```

```
{
```

```
    TreeNode *Tmp = Root;
```



```

    while(Tmp)
    {
        if(Tmp->Data == Key)
            return Tmp;
        else if(Tmp->data < Key)
            Tmp = Tmp->Lchild;
        else
            Tmp = Tmp->Rchild;
    }
    return NULL;
}

```

#### Recursive-

```

TreeNode *BSTree :: Rec_Search(TreeNode *root, int key)
{
    if(root == Null)
        return(root);
    else
    {
        if(root->Data < Key)
            root = Rec_Search(root->Lchild);
        else if(root->data > Key)
            root = Rec_Search(root->Rchild);
    }
}

```

**Conclusion:** Successfully implemented Binary search tree as an ADT using linked list in C++ language.



## Assignment 2:

### Problem Statement:

Write a program in C++ to create a binary inorder threaded tree & perform following tree traversals

1. In – order traversals
2. Pre – order traversals
3. Post – order traversals

### Implementation:

A node in threaded binary tree is represented as follows:

LBIT	LCHILD	DATA	RCHILD	RBIT
------	--------	------	--------	------

LBIT & RBIT are the two extra fields used to distinguish between threads & normal pointers.

LBIT(P) = 1           if LCHILD is a normal pointer

LBIT(P) = 0           if LCHILD is a thread

RBIT(P) = 1           if RCHILD is a normal pointer

RBIT(P) = 0           if RCHILD is a thread

Two NULL links LCHILD of leftmost node & RCHILD of right most node point to head node.

We consider that the complete tree is left subtree of head node.

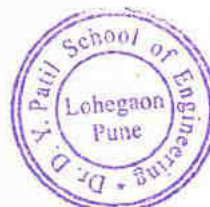

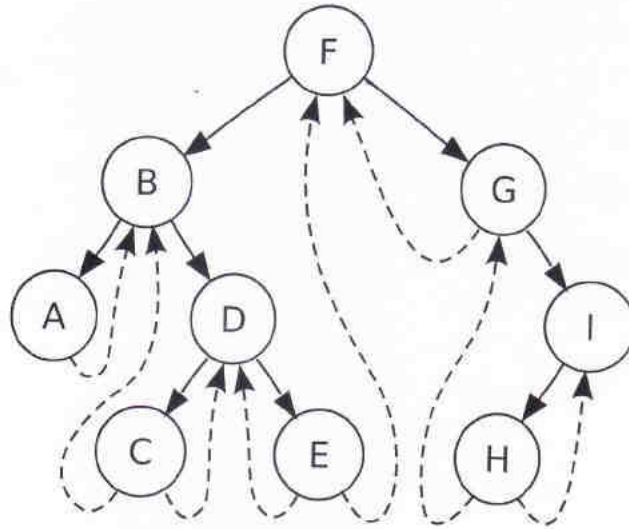

In Threaded Binary Tree

Memory representation of Threaded inorder tree equivalent to given binary tree is:

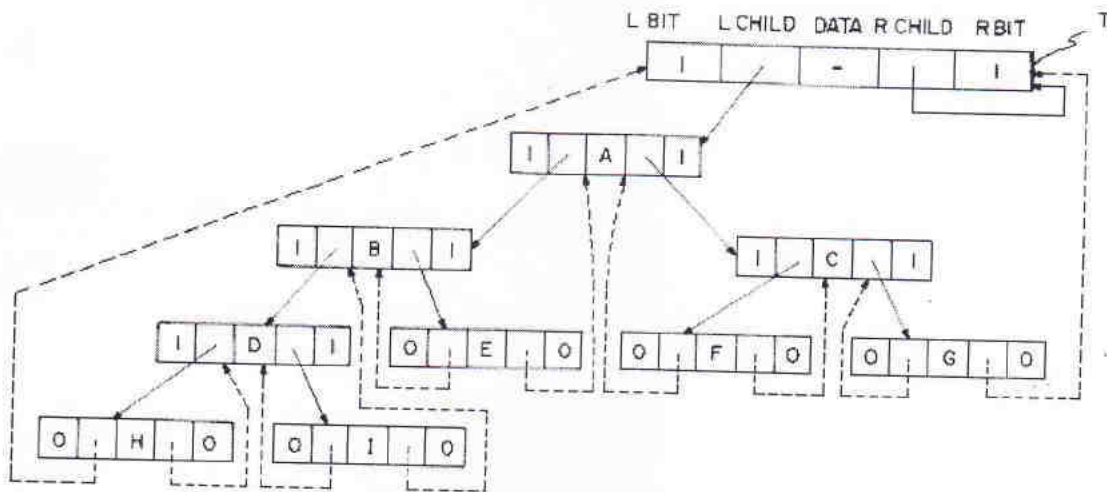

**Create () Function:**

Getnode (parent)

Accept from user Data (parent)

Left(parent) = Head

Right(parent) = Head



```

Lbit(parent) = Thread
Rbit(parent) = Thread
Left(Head) = parent
while(1)
begin
    Ask user if more nodes are to be added to tree
    If no then break
    Getnode (newnode)
    Accept from user Data(newnode)
    Initialize Lbit (newnode) = Rbit (newnode) = Thread
    Initialize parent = left(head)
    while(1)
    begin
        Ask user if newnode is left or right of current parent
        If left
            If Lbit (parent) != thread then
                Parent = left (parent)
            Else
                Left(newnode) = left(parent)
                Right(newnode) = parent
                Left(parent) = newnode
                Lbit(parent) = pointer
                Break
        If right
            If Rbit (parent) != thread then

```



```

        Parent = Right (parent)
    Else
        Right (newnode) = Right (parent)
        Left(newnode) = parent
        Right (parent) = newnode
        Rbit(parent) = pointer
        Break
    End
End
End of create

```

**Tinorder() function:**

Let temp be a reference to a node of threaded tree

Initialize temp to point to head

while(1)

begin

temp = insucc(temp)

if temp = head then break

print data(temp)

end

end tinorder

insucc() function:





Let temp be a reference to a neode

Initialize temp = right (node)

If Rbit[node] = pointer then

    while (lbit[temp] != thread)

    begin

        temp left(temp)

    end

return(temp)

end insucc

**Tpreorder() function:**

Let temp be a reference to a node structure

Initialize temp = left(head)

while( temp != head)

begin

    while(1)

    begin

        print Data(temp)

        if Lbit(temp) = Thraed then break

        temp = left(temp)

    end

    while(Rbit(temp) != pointer)

    begin

        temp = right(temp)

    end



```

    temp = right(temp)
end
end Tpreorder

```

### **Tpostorder() Function:**

Let temp be a reference to a node structure

Let op be a string

Let i be a counter

Initialize temp = left(head)

Initialize i = 0

while(1)

begin

while(1)

begin

op[i] = Data(temp)

i = i+1

if (rbit(temp) = Thread) then break

temp = right(temp)

end

while(Lbit(temp) != pointer)

begin

temp = left(temp)

end

if temp = head then break

temp = left(temp)



end

print op in reverse order

end of Tpostorder

**Conclusion:** Successfully implemented Threaded Binary tree as an ADT using linked list in C++ language.





Dr. D. Y. Patil Group of Institutions' Technical Campus  
**Dr. D. Y. PATIL SCHOOL OF ENGINEERING**  
Dr. D. Y. Patil Knowledge City, Charholi Bk., Via. Lohegaon, Pune - 412 105.  
Department of **Electronics and Telecommunication Engineering**

**Broadband Communication Systems**  
**(B.E, 2015 Course)**

# LABORATORY MANUAL

**List of the Experiments (Minimum 8 experiments are to be performed).**

1. Estimation of Numerical aperture of fiber
2. Plot the characteristics of various sources and detectors
3. Measure attenuation of MMSI and SMSI fiber and comment on the result based on attenuation due to increase in length as well as loss due to bend
4. Set up a digital link and analyze.
5. Tutorial on Power budget and time budget analysis of optical fiber system.
6. Establishing a direct communication link between Uplink Transmitter and Downlink Receiver using tone signal.
7. To set up an Active Satellite link and demonstrate Link Fail Operation
8. To establish an AUDIO-VIDEO satellite link between Transmitter and Receiver.
9. To communicate VOICE signal through satellite link.
10. To transmit and receive three separate signals (Audio, Video, Tone) simultaneously through satellite Link.
11. To transmit and receive PC data through satellite link.
12. Tutorial on satellite link design
13. Students, as a part of their term work, should visit satellite earth station and submit a report of visit. (Optional)







Dr. D. Y. Patil Group of Institutions' Technical Campus  
**Dr. D. Y. PATIL SCHOOL OF ENGINEERING**  
Dr. D. Y. Patil Knowledge City, Charholi Bk., Via. Lohegaon, Pune - 412 105.  
Department of **Electronics and Telecommunication Engineering**

### Index

Sr. No.	Name of Experiment/Assignment	Page No.
1	Estimation of Numerical aperture of fiber	
2	Plot the characteristics of various sources and detectors	
3	Measure attenuation of MMSI and SMSI fiber and comment on the result based on attenuation due to increase in length as well as loss due to bend	
4	Set up a digital link and analyze.	
5	Tutorial on Power budget and time budget analysis of optical fiber system.	
6	Establishing a direct communication link between Uplink Transmitter and Downlink Receiver using tone signal.	
7	To set up an Active Satellite link and demonstrate Link Fail Operation	
8	To establish an AUDIO-VIDEO satellite link between Transmitter and Receiver.	
9	To communicate VOICE signal through satellite link.	
10	To transmit and receive three separate signals (Audio, Video, Tone) simultaneously through satellite Link.	
11	To transmit and receive PC data through satellite link.	
12	Tutorial on satellite link design	
13	Students, as a part of their term work, should visit satellite earth station and submit a report of visit. (Optional)	





## Experiment No. 1

### Estimation of Numerical Aperture of fiber

**Aim:** To Estimate Numerical Aperture (NA) of fiber

**Apparatus:** Optical trainer Kit, Numerical aperture scale, 1 meter fiber cable.

#### Theory:

For light rays to be propagated along a fiber they must fall within the fibers acceptance angle, the numerical aperture of the fiber is an indication of how much light fiber can accept to propagate through it. Numerical Aperture refers to the maximum angle at which the light incident on the fiber end is totally internally reflected and is transmitted properly along the fiber.

The cone formed by the rotation of this angle along the axis of the fiber is the cone of acceptance. The light ray should strike the fiber end within its cone of acceptance else it is refracted out of fiber cone.

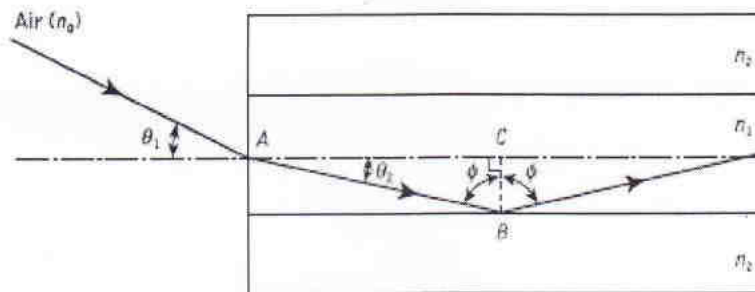

Fig.1. The Path for a meridional ray launched in to fiber

Above figure shows a light ray incident on the fiber core at an angle  $\theta_1$  to the fiber axis which is less than the acceptance angle for the fiber  $\theta_a$ . The ray enters the fiber from a medium (air) of refractive index  $n_0$ , and the fiber core has a refractive index  $n_1$ , which is slightly greater than the cladding refractive index  $n_2$ .

NA is defines for step index in air as

$$NA = n_0 \sin \theta_a = \sqrt{n_1^2 - n_2^2}$$

$\theta_a$  = maximum acceptance angle

$n_1$  = core refractive index

$n_2$  = cladding refractive index

It is assumed that light is incident on fiber end face from air with refractive index ( $n_0$ ) of unity. The numerical aperture can also be defined in terms of relative refractive index difference ( $\Delta$ ) as,

$$NA = n_1 \sqrt{2\Delta}$$





**Procedure:**

1. Switch on the power supply.
2. Adjust fiber such that it just touch light source.
3. Take reading on vertical scale as reference reading.
4. Adjust distance 'L' between fiber and light source to 10mm.
5. Adjust fiber in horizontal position such that we get maximum volt meter reading and take vernier scale reading.
6. Now we have to take reading at different horizontal positions. Practically
7. Maximum angle of incidence of light corresponds to half power point, that is when volt meter reading is 0.5 times the max reading. So adjust fiber at different horizontal points using vernier for horizontal movement.
8. Take vernier scale reading when voltmeter reading is 0.5 times max reading. This reading is D1.
9. Similarly take reading in opposite direction say D2.

Now refer to diagram

$$N.A = \sin(\tan^{-1}[D/2L])$$

Where,

$$D = D2 - D1 \text{ or } D1 - D2$$

L = distance between fiber and light source.

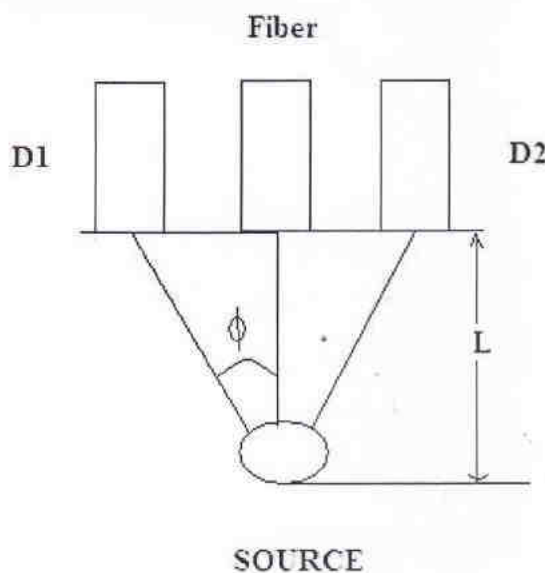

Fig.2. Experimental setup for measurement of NA of fiber.







- 10. Repeat the procedure at L=20mm.
- 11. Calculate average value of N.A.

**Observation Table:**

Sr. no	L(distance between light source & fiber)	Distance	Voltmeter reading	D=D2-D1 or D=D1-D2	Numerical Aperture
1.		D1=			
		D2=			
2.		D1=			
		D2=			
3.		D1=			
		D2=			

**Calculations:**





Dr. D. Y. Patil Group of Institutions' Technical Campus  
**Dr. D. Y. PATIL SCHOOL OF ENGINEERING**  
Dr. D. Y. Patil Knowledge City, Charholi Bk., Via. Lohegaon, Pune - 412 105.  
Department of **Electronics and Telecommunication Engineering**

**Conclusion:**





## Experiment No. 2

### Plot the characteristics of various sources and detectors

**Aim:** A) To plot the Electrical & optical characteristics of LED as a light source.

B) To plot V-I characteristics and photo diode as a light detector.

**Apparatus:** Trainer kit, DSO, connecting probes.

**Theory:** In Optical communication system, electrical signal is first converted into optical signal with the help of E/O conversion device such as **LED (Light Emitting diode) & LASER diode**. After this optical signal is transmitted through optical fiber, it is then retrieved in its original form with the help of O/E conversion device which is a **photo detector**.

- A LED is semiconductor device that emits light when an electric current is applied to it. LED contains a P-N junction, which is forward bias when LED is operating.

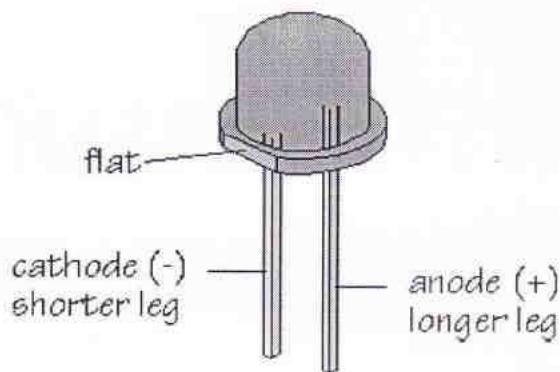
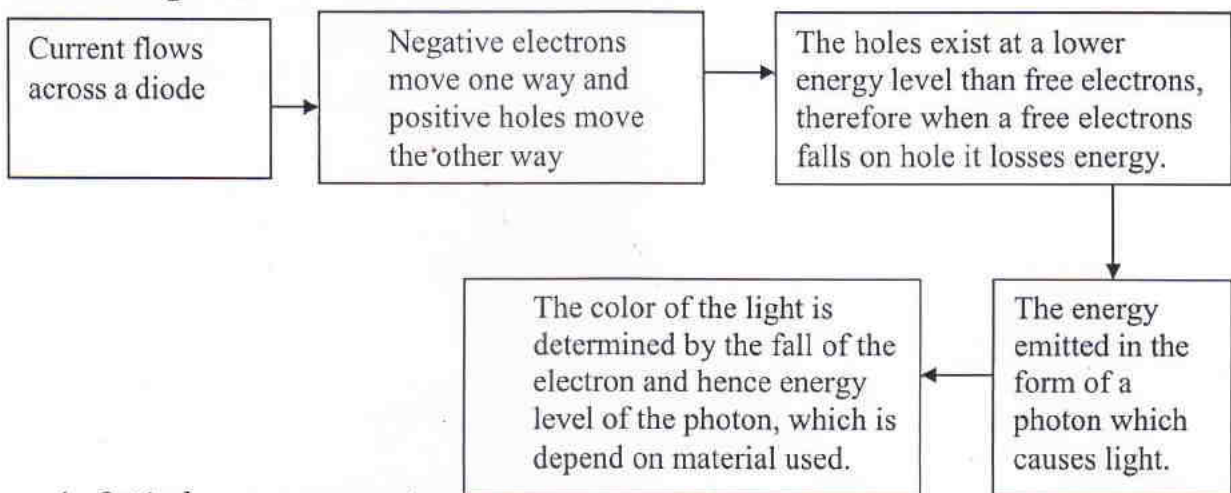

Fig.1. LED & its connections

#### How a Led glows?



1. Optical source converts



the electrical energy into equivalent optical source, when P-N junction is forward biased. It is achieved by LED & LASER based on principle of photon emission. Photon emission takes place when electrons fall back from conduction band to valance band.

2.

CONDUCTION BAND

ENERGY GAP

VALENCE BAND

3. The wavelength of light emitted & its color depends on the band gap energy of the materials forming P-N junction.
4. LED uses spontaneous emission process of light, in which there is random emission of light in surrounding direction.
5. The various impurities added during doping process to establish wavelength of the emitted light. The wavelength determines the color of the light & if it is visible or invisible (infrared).
6. LEDs are made up of Gallium Arsenide (GaAs), Gallium Arsenide phosphide (GaAsP) or Gallium phosphide (GaP).
7. GaAs LED emit infrared radiation which is invisible.
8. GaAsP produces either red or yellow visible light.
9. GaP produces red or green visible light.
10. Forward voltage in silicon diode is 0.7 volts & in LEDs it is always greater in between 1.2V & 3.2V. Reverse breakdown for LED is much less.

**Note:** The silicon & germanium diode does not show optical emission because they are essentially heat producing Materials & are very poor at producing light. & also because silicon & Germanium are indirect band gap material & the material used for LED have direct band gap.

Indirect band gap: a semiconductor with an indirect band gap, showing that an electron cannot shift from the lowest-energy state in the conduction band to the highest-energy state in the valence band without a change in momentum.

Direct band gap: a semiconductor with a direct band gap, showing that an electron can shift from the lowest-energy state in the conduction band to the highest-energy state in the valence band without a change in crystal momentum. Typical indicator LEDs require no more than 30-60milliwatts of electrical power.

#### Types of LED:

Following are types of LED,

- 1) Dome LED
- 2) Surface emitting LED
- 3) Edge emitting LED





**B)**  
**Theory:**

The basic detection process in an intrinsic absorption is illustrated is shown in the following figure, which shows a p-n photodiode. This device is reverse biased and the electric field developed across the p-n junction sweeps mobile carrier (holes and electrons) to their respective majority sides (p and n type material). A depletion region or layer is therefore created on either side of the junction. This barrier has the effect of stopping the majority carriers crossing the in opposite direction to the field. However, the field accelerates minority carriers from both sides to the opposite side of the junction forming the reverse leakage current of the diode Thus intrinsic conditions are created in depletion region

A photon incident in or near the depletion region of this device which has an energy greater than or equal to the band gap energy ( $E_g$ ) of the fabricating material (i.e.  $hf \geq E_g$ ) will excite electron from the valence band and is known as the photo generation of an electron-hole (carrier) pair, as shown in following figure,

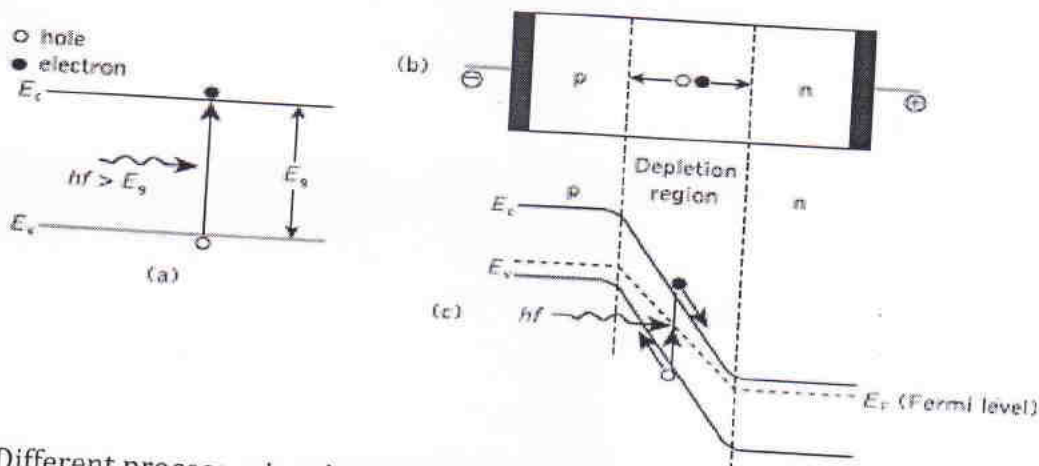

Fig.1. Different processes involved in detection of light signal by a photodiode.

Carrier pairs so generated near the junction are separated and swept (drift) under the influence of the electric to produce a displacement by the current in the external circuit in access of any reverse leakage current.

Photo generation and the separation of a carrier pair generation. However since long carrier drift times in the depletion region restrict the speed of operation of the photodiode it is necessary to limit its width. Thus, there is tradeoff between the no. of photons absorbed (sensitivity) and the speed of response.





**Procedure:**

1. Switch on the power supply.
2. Connect the optical transmitter in test circuit.
3. Connect anode of transmitter to voltmeter and cathode to current meter.
4. Vary voltage and current using pot.
5. Plot the graph of voltage and current.
6. Also observe optical characteristics by connecting optical fiber cable between transmitter and receiver of optical power meter.
7. Vary current using pot and take readings of power.
8. Plot the graph of voltage and current.
9. For V-I characteristics of receiver adjust transmitter current to 15 mA.
10. Connect optical receiver in reverse bias condition.
11. Connect anode to current meter and cathode to voltmeter.
12. Connect fiber cable between transmitter and receiver.
13. Vary voltage and current using pot and plot the graph.
14. Repeat the procedure for different transmitter current.

**Observation Table:**

- 1) Table for VI characteristics of LED

Sr.No.	Voltage (V)	Current (mA)	Sr.No.	Voltage (V)	Current (mA)
1			11		
2			12		
3			13		
4			14		
5			15		
6			16		
7			17		
8			18		
9			19		
10			20		





Dr. D. Y. Patil Group of Institutions' Technical Campus  
**Dr. D. Y. PATIL SCHOOL OF ENGINEERING**  
Dr. D. Y. Patil Knowledge City, Charholi Bk., Via. Lohegaon, Pune – 412 105.  
Department of **Electronics and Telecommunication** Engineering

2) Table for Optical characteristics of fiber.

Sr. No.	Current (mA)	Power (mW)
1		
2		
3		
4		
5		
6		
7		
8		

3) Table for VI characteristics of Photodiode

Sr. No.	Transmitter Current		Transmitter Current		Transmitter Current	
	Voltage(V)	Current(A)	Voltage(V)	Current(A)	Voltage(V)	Current(A)
1						
2						
3						
4						
5						
6						
7						
8						
9						
10						

Conclusion:





### Experiment No. 3

#### **Measure attenuation of MMSI and SMSI fiber and comment on the result based on attenuation due to increase in length.**

**Aim:** Measure attenuation of MMSI and SMSI fiber and comment on the result based on attenuation due to increase in length.

**Apparatus:** Optical trainer kit, optical fiber cables of different length, DSO

**Theory:**

The attenuation or transmission loss of optical fibers has proved to be one of the most important factors in bringing about their wide acceptance in telecommunications. As channel attenuation largely determined the maximum transmission distance prior to signal restoration

Attenuation is loss of power. During transmission, light pulse lose some of their photons, thus reduce their amplitude. Attenuation for a fiber is usually specified in decibels per kilometer. For commercially available fibers attenuation ranges from 1 dB / km for premium small-core glass fibers to over 2000 dB / Km for a large core plastic fiber.

Loss is by definition indicated by negative decibels. In common usage, discussions of loss omit the negative sign. The basic measurement for loss in a fiber is done by taking the logarithmic ratio of the input power ( $P_i$ ) to the output power ( $P_o$ ).

$$\alpha_{(dB)}L = 10 \log_{10} \frac{P_i}{P_o}$$

Where  $\alpha$ (dB) is the signal attenuation per unit length in decibels which is also referred to as the fiber loss parameter and  $L$  is the fiber length.

A number of mechanisms are responsible for the signal attenuation within optical fiber. These mechanisms are influenced by the material composition, the preparation and purification technique and the waveguide structure. They may be categorized within several major areas which include material absorption, material scattering (linear and nonlinear scattering), curve and micro bending losses, mode coupling radiation losses and losses due to leaky modes. There are also losses at connectors and splices. For a low loss single mode fiber the graph of attenuation with respect to wavelength is as shown in fig.1.

The attenuation in a fiber can be reduces by using techniques like, use of proper fabrication techniques like vapor phase axial deposition. It can also be reduced by using a good quality material for fiber manufacturing.

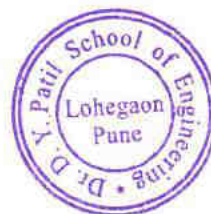



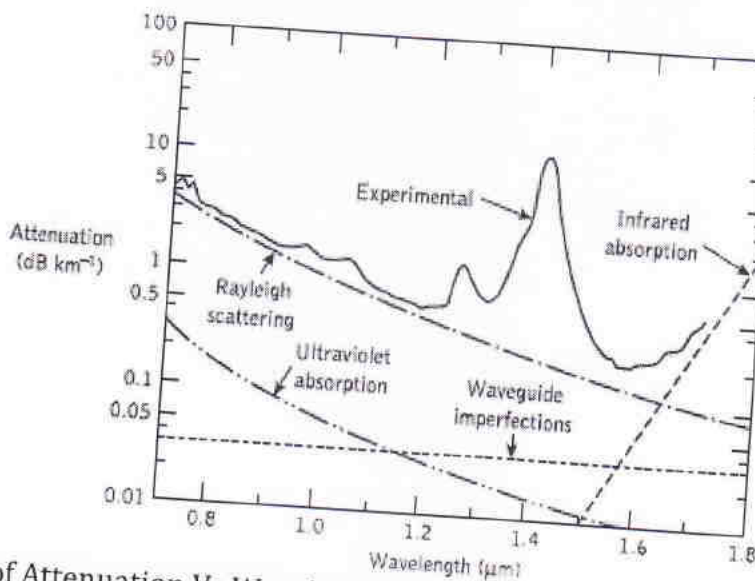

Fig.1. Graph of Attenuation Vs Wavelength for a single mode fiber.

**Procedure:**

1. Switch on the power supply.
2. Adjust output of signal generator to 1 Vpp using amplitude adjust pot and connect it to input of optical transmitter.
3. Connect 0.33 meter fiber cable between optical transmitter and receiver.
4. Measure output of receiver (peak to peak) say V1.
5. Similarly repeat this procedure for 0.66 m and 1m fiber cable and measure output of receiver say V2 and V3 resp.
6. Calculate attenuation loss using following procedure-
  - a) Loss 1 =  $20\log(V1/V2)$  dB
  - b) Loss 2 =  $20\log(V2/V3)$  dB
  - c) Loss 3 =  $20\log(V1/V3)$  dBWhere,  
V1=output for 0.33m fiber  
V2=output for 0.66m fiber  
V3=output for 1m fiber
7. Calculate the avg. loss per 1m of fiber cable as  
Avg. loss =  $[Loss\ 3 + Loss\ 2 + Loss\ 1] / 3$  in dB/m





**OBSERVATION TABLE:**

**1.  $V_{in} =$**

LENGTH OF FIBER (m)	OUTPUT (volts)	PROPAGATION LOSS (dB)	AVG. LOSS (dB/m)
L1=0.33m	V1=		
L2=0.66m	V2=		
L3=1m	V3=		

**2.  $V_{in} =$**

LENGTH OF FIBER (m)	OUTPUT (volts)	PROPAGATION LOSS (dB)	AVG. LOSS (dB/m)
L1=0.33m	V1=		
L2=0.66m	V2=		
L3=1m	V3=		

**3.  $V_{in} =$**

LENGTH OF FIBER (m)	OUTPUT (volts)	PROPAGATION LOSS (dB)	AVG. LOSS (dB/m)
L1=0.33m	V1=		
L2=0.66m	V2=		
L3=1m	V3=		

**Conclusion:**





Dr. D. Y. Patil Group of Institutions' Technical Campus  
**Dr. D. Y. PATIL SCHOOL OF ENGINEERING**  
Dr. D. Y. Patil Knowledge City, Charholi Bk., Via. Lohegaon, Pune - 412 105.  
Department of **Electronics and Telecommunication Engineering**

### Experiment No. 4

#### Transmission of Digital signal through fiber optic link

**Aim:** To Study Transmission of Digital signal through fiber optic link.

**Apparatus:** Experimental kit, DSO, Optical fiber cable.

#### Theory:

The non-linearity within the emitter LED & photo transistor causing distortion of the signal at the receiver output are the disadvantages associated with amplitude modulating a light source by analog means. Linearity is not a problem if the light beam is switched 'On' & 'Off' with a digital signal, since the detector output is simply squared up by a comparator circuit. To overcome problems associated with amplitude modulation of a light beam by analog means, analog signals are often used to vary or modulate some characteristic of a digital signal (e.g. frequency or pulse width.). The digital signal being used to switch the light beam 'On' & 'Off'.

#### DIGITAL OPTICAL LINK:

In this link we have use digital fiber link. Ckt diagram is given on next page at optical transmitter we have used RED LED and transistor as switch. When input to transistor is high, there is no light output and when input is low light is emitted. This light is coupled to optical receiver through one meter length, secondary coated plastic fiber. At receiver we have used TLL 81 phototransistor, amplifier and again switching transistor.

When light fall on optical receiver input to switching transistor is high and so final output of link is low, and when no light fall input to switching transistor is low and so final output is high. in this way we get same output at receiver which we have given to transmitter.

The bandwidth is depends on  $T_r$  (rise time),  $T_f$  (fall time) and value of load resistance in detector circuit. We have provided pattern generator with variable clock frequency. At detector two load resistances R1 (1K) and R2 (4.7K) are provided. You can observe effect of value of load resistance on B.W.

#### Procedure:

1. Switch On the power supply.
2. Connect 5V to input of optical transmitter. Observe output at anode of transmitter and cathode of optical receiver and final receiver output.
3. Connect ground to input of optical transmitter. Observe output at anode of transmitter and cathode of optical receiver and final receiver output.  
Now to observe effect of value of load resistance on BW:
4. Keep frequency of clock generator minimum.
5. Connect pattern (P1 or P2) output to input of transmitter.





6. Observe waveform at anode of optical transmitter with input pattern on dual scope CRO, it is inverted.
7. Connect fiber cable between optical transmitter and receiver.
8. Connect anode of optical receiver to R1 1K as RL.
9. Observe output at anode of optical receiver.
10. Observe output at OP-AMP amplifier.
11. Observe final output of receiver. It is same as input pattern.
12. Now increase clock frequency from minimum to maximum and observe its effect on final output of receiver.
13. Repeat steps 8-12 for R2 (4.7K).
14. What is your observation, as RL increases bandwidth decreases.

**Observations:**

Sr.No	Test point	Vpp(V)	Frequency(Hz)	Rise time( $\mu$ sec)
1	Pattern P1			
2	P1 :anode of Tx			
3	P1 :anode of Rx(R1)			
4	P1 :anode of Rx(R2)			
5	P1:Final output			
6	Pattern P2			
7	P2:anode of Tx			
8	P2:anode of Rx(R1)			
9	P2:anode of Rx(R2)			
10	P2:Final output			

**Conclusion:**





### **Experiment No. 5**

#### **Establishing a direct communication link between Uplink Transmitter and Downlink Receiver using tone signal.**

**Aim:-** To establish a direct communication link between Transmitter and downlink receiver using tone Signal.

**Apparatus:-** Satellite Transmitter, Satellite Transponder, Satellite Receiver, connecting cords, antennas.

#### **Theory:**

##### **Uplink Transmitter:**

In uplink station the signal has to be sent at a different frequency usually in higher 1GHz band to avoid interference with link signal. Another function performed by uplink station is to control highly internal function of satellite. up links are controlled so that transmitted micro wave beam is extremely narrow in order not to interface with adjacent satellite.

##### **Transponder:**

Each satellite has a number of transponder with access to a pair of receive / transmit antennas and associated electronics for each channel. For example in Europe the uplink sends a signal at a frequency of about 14 GHz. These are received downlink converted in frequency of about 11/ 12 GHz and boosted by high power amplifier for retransmission to earth. Separate transponders are used for each channel and are powered by solar panels with backup batteries for eclipse protection.

##### **Down Link Receiver:**

The medium used to transmit signal from satellite to earth is microwave electromagnetic radiation which is much higher in frequency normal broadcast TV signal in VHF / UHF bands. Microwave still exhibit a wave like nature, but inherit a tendency to serve attenuation by water vapors or any obstruction in line of sight of antenna. The transmitted micro wave power is extremely weak by the time it reaches earth and unless well designed equipment is used and certain installation precaution are taken, the back round noise can ruin the signal.

##### **Antenna:**

To radiate or receive electromagnetic waves an antenna is required. Antenna is system of elevated conductors which couples or matches the transmitter or receiver to free space. A transmitting antenna connecting to a transmitter by transmission line, forces electromagnetic waves in to free space which travel in space with velocity of light.





Dr. D. Y. Patil Group of Institutions' Technical Campus  
**Dr. D. Y. PATIL SCHOOL OF ENGINEERING**  
Dr. D. Y. Patil Knowledge City, Charholi Bk., Via. Lohegaon, Pune - 412 105.  
Department of **Electronics and Telecommunication Engineering**



Fig.1. Block diagram of satellite link

**PROCEDURE:-**

1. Connect the satellite uplink transmitter to AC mains.
2. Switch on the transmitter by mains switch .
3. The transmitting frequency can be selected by knob. The frequency can be changed from 2390-2468 -2490-2510 MHz.
4. The transmitter on -off switch will switch on -off the transmission.
5. Connect the satellite downlink receiver to AC mains.
6. Switch on the receiver by mains switch .
7. The receiving frequency can be selected by knob. The frequency can be changed from 2390-2468 -2490-2510 MHz.
8. Select a downlink frequency which is less than uplink frequency.
9. Switch on the transponder by mains switch .
10. The transmitting frequency & receiving frequency can be selected by knob. The frequency can be changed from 2390-2468 -2490-2510 MHz.
11. Now connect tone signal input socket onboard uplink Transmitter by patch cord.
12. Keep downlink receiver speaker switch in ON position and you will be to hear tone in speaker of receiver.

**Conclusion: -**





### **Experiment No. 6**

#### **To set up an Active Satellite link and demonstrate Link Fail Operation**

**Aim:-** To setup an active satellite link and demonstrate link fail operations.

**Apparatus :-** Satellite Transmitter, Satellite Transponder, Satellite Receiver, connecting cords, antennas.

#### **Theory:**

##### **Uplink Transmitter:**

In uplink station the signal has to be sent at a different frequency usually in higher 1GHz band to avoid interference with link signal. Another function performed by uplink station is to control highly internal function of satellite. up links are controlled so that transmitted micro wave beam is extremely narrow in order not to interface with adjacent satellite.

##### **Transponder:**

Each satellite has a number of transponder with access to a pair of receive / transmit antennas and associated electronics for each channel. For example in Europe the uplink sends a signal at a frequency of about 14 GHz. These are received downlink converted in frequency of about 11/ 12 GHz and boosted by high power amplifier for retransmission to earth. Separate transponders are used for each channel and are powered by solar panels with backup batteries for eclipse protection.

##### **Down Link Receiver:**

The medium used to transmit signal from satellite to earth is microwave electromagnetic radiation which is much higher in frequency normal broadcast TV signal in VHF / UHF bands. Microwave still exhibit a wave like nature, but inherit a tendency to serve attenuation by water vapors or any obstruction in line of sight of antenna. The transmitted micro wave power is extremely weak by the time it reaches earth and unless well designed equipment is used and certain installation precaution are taken, the background noise can ruin the signal.

##### **Antenna:**

To radiate or receive electromagnetic waves an antenna is required. Antenna is system of elevated conductors which couples or matches the transmitter or receiver to free space. A transmitting antenna connecting to a transmitter by transmission line, forces electromagnetic waves in to free space which travel in space with velocity of light.

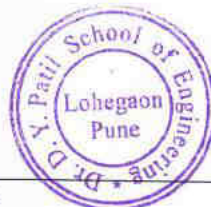

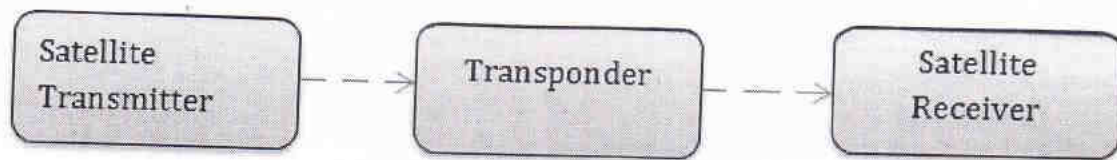

Fig.1. Block diagram of satellite link

### Procedure:

1. Connect the satellite uplink transmitter to AC mains.
2. Switch on the transmitter by mains switch .
3. The transmitting frequency can be selected by knob. The frequency can be changed from 2390-2468 -2490-2510 MHz.
4. The transmitter on -off switch will switch on -off the transmission.
5. Connect the satellite downlink receiver to AC mains.
6. Switch on the receiver by mains switch .
7. The receiving frequency can be selected by knob. The frequency can be changed from 2390-2468 -2490-2510 MHz.
8. Select a downlink frequency which is less than uplink frequency.
9. Switch on the transponder by mains switch .
10. The transmitting frequency & receiving frequency can be selected by knob. The frequency can be changed from 2390-2468 -2490-2510 MHz.
11. Now connect tone signal input socket onboard uplink Transmitter by patch cord.
12. Keep downlink receiver speaker switch in ON position and you will be to hear tone in speaker of receiver.
13. When the frequency combinations of transmitter and receiver are mismatched no signal is received and no tone can be heard on the downlink receiver. This demonstrates satellite link fail operation.

### Conclusion:







Dr. D. Y. Patil Group of Institutions' Technical Campus  
**Dr. D. Y. PATIL SCHOOL OF ENGINEERING**  
Dr. D. Y. Patil Knowledge City, Charholi Bk., Via. Lohegaon, Pune - 412 105.  
Department of **Electronics and Telecommunication Engineering**

### Experiment No. 7

## To establish an AUDIO-VIDEO satellite link between Transmitter and Receiver

**Aim:-** To establish an AUDIO-VIDEO satellite link between Transmitter and Receiver.

**Apparatus:-** Satellite Transmitter, Satellite Transponder, Satellite Receiver, connecting cords, antennas, DVD Player, TV & SPEAKER.

### Theory:

**DVD player :** It is input block, used to give audio-video signal.

### Uplink Transmitter:

In uplink station the signal has to be sent at a different frequency usually in higher 1GHz band to avoid interference with link signal. Another function performed by uplink station is to control highly internal function of satellite. up links are controlled so that transmitted micro wave beam is extremely narrow in order not to interface with adjacent satellite.

### Transponder:

Each satellite has a number of transponder with access to a pair of receive / transmit antennas and associated electronics for each channel. For example in Europe the uplink sends a signal at a frequency of about 14 GHz. These are received downlink converted in frequency of about 11/ 12 GHz and boosted by high power amplifier for retransmission to earth. Separate transponders are used for each channel and are powered by solar panels with backup batteries for eclipse protection.

### Down Link Receiver:

The medium used to transmit signal from satellite to earth is microwave electromagnetic radiation which is much higher in frequency normal broadcast TV signal in VHF / UHF bands. Microwave still exhibit a wave like nature, but inherit a tendency to serve attenuation by water vapors or any obstruction in line of sight of antenna. The transmitted micro wave power is extremely weak by the time it reaches earth and unless well designed equipment is used and certain installation precaution are taken, the background noise can ruin the signal.

### Antenna:

To radiate or receive electromagnetic waves an antenna is required. Antenna is system of elevated conductors which couples or matches the transmitter or receiver to free

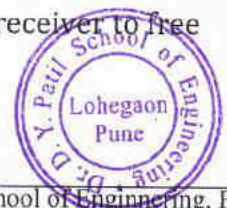



space. A transmitting antenna connecting to a transmitter by transmission line, forces electromagnetic waves in to free space which travel in space with velocity of light.

**TV :** It is output module ,used to see output.

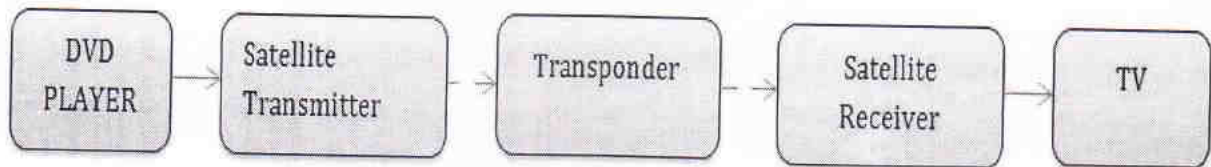

Fig.1. Block diagram of audio-video satellite link

**Procedure:**

1. Connect the satellite uplink transmitter to AC mains.
2. Switch on the transmitter by mains switch .
3. The transmitting frequency can be selected by knob. The frequency can be changed from 2390-2468 -2490-2510 MHz.
4. The transmitter on -off switch will switch on -off the transmission.
5. Connect the satellite downlink receiver to AC mains.
6. Switch on the receiver by mains switch .
7. The receiving frequency can be selected by knob. The frequency can be changed from 2390-2468 -2490-2510 MHz.
8. Select a downlink frequency which is less than uplink frequency.
9. Switch on the transponder by mains switch.
10. The transmitting frequency & receiving frequency can be selected by knob. The frequency can be changed from 2390-2468 -2490-2510 MHz.
11. Connect the Audio/Video signal at the input socket provided on the Uplink Transmitter, Video at video input and audio at audio in input.
12. Connect TV monitor to the Audio/Video o/p of downlink receiver. Set TV in AV mode.
13. The TV monitor will display video and audio signal that you have connected to uplink transmitter input.

**Conclusion:**





## Experiment No. 8

### To communicate voice signal through satellite Link

**Aim:-** To communicate voice signal through satellite Link.

**Apparatus:-** Satellite Trainer kit, connecting cords.

#### Theory:

**MIC :** It is input device ,used to to get voice signal as an input.

#### Uplink Transmitter:

In uplink station the signal has to be sent at a different frequency usually in higher 1GHz band to avoid interference with link signal. Another function performed by uplink station is to control highly internal function of satellite. up links are controlled so that transmitted micro wave beam is extremely narrow in order not to interface with adjacent satellite.

#### Transponder:

Each satellite has a number of transponder witch access to a pair of receive / transmit antennas and associated electronics for each channel. For example in Europe the uplink sends a signal at a frequency of about 14 GHz. These are received downlink converted in frequency of about 11/ 12 GHz and boosted by high power amplifier for retransmission to earth. Separate transponders are used for each channel and are powered by solar panels with backup batteries for eclipse protection.

#### Down Link Receiver:

The medium used to transmit signal from satellite to earth is microwave electromagnetic radiation which is much higher in frequency normal broadcast TV signal in VHF / UHF bands. Microwave still exhibit a wave like nature, but inherit a tendency to serve attenuation by water vapors or any obstruction in line of sight of antenna. The transmitted micro wave power is extremely weak by the time it reaches earth and unless well designed equipment is used and certain installation precaution are taken, the back round noise can ruin the signal.

#### Antenna:

To radiate or receive electromagnetic waves an antenna is required. Antenna is system of elevated conductors which couples or matches the transmitter or receiver to free space. A transmitting antenna connecting to a transmitter by transmission line, forces electromagnetic waves in to free space which travel in space with velocity of light.





**Speaker :** It is an output device ,used to get the output.



**Procedure:**

1. Connect the satellite uplink transmitter to AC mains.
2. Switch on the transmitter by mains switch .
3. The transmitting frequency can be selected by knob. The frequency can be changed from 2390-2468 -2490-2510 MHz.
4. The transmitter on-off switch will switch on -off the transmission.
5. Connect the satellite downlink receiver to AC mains.
6. Switch on the receiver by mains switch .
7. The receiving frequency can be selected by knob. The frequency can be changed from 2390-2468 -2490-2510 MHz.
8. Select a downlink frequency which is less than uplink frequency.
9. Switch on the transponder by mains switch and frequency display will come on.
10. The transmitting frequency & receiving frequency can be selected by knob. The frequency can be changed from 2390-2468 -2490-2510 MHz.
11. Connect microphone to the socket onboard uplink transmitter.
12. Now switch on the speaker onboard downlink receiver.
13. Speak through the microphone and you will hear the same sound in speaker of downlink receiver.

**Conclusion:**





### Experiment No. 9

#### **To transmit and receive three separate signals (Audio, Video, Tone) simultaneously through satellite Link**

**Aim:** - To transmit and receive three separate signals (Audio, video, tone) simultaneously through satellite link.

**Apparatus:**-Satellite Trainer kit, connecting cords.

#### **Theory:**

##### **Uplink Transmitter:**

In uplink station the signal has to be sent at a different frequency usually in higher 1GHz band to avoid interference with link signal. Another function performed by uplink station is to control highly internal function of satellite. up links are controlled so that transmitted micro wave beam is extremely narrow in order not to interface with adjacent satellite.

##### **Transponder:**

Each satellite has a number of transponder with access to a pair of receive / transmit antennas and associated electronics for each channel. For example in Europe the uplink sends a signal at a frequency of about 14 GHz. These are received downlink converted in frequency of about 11/ 12 GHz and boosted by high power amplifier for retransmission to earth. Separate transponders are used for each channel and are powered by solar panels with backup batteries for eclipse protection.

##### **Down Link Receiver:**

The medium used to transmit signal from satellite to earth is microwave electromagnetic radiation which is much higher in frequency normal broadcast TV signal in VHF / UHF bands. Microwave still exhibit a wave like nature, but inherit a tendency to serve attenuation by water vapors or any obstruction in line of sight of antenna. The transmitted micro wave power is extremely weak by the time it reaches earth and unless well designed equipment is used and certain installation precaution are taken, the back round noise can ruin the signal.

##### **Antenna:**

To radiate or receive electromagnetic waves an antenna is required. Antenna is system of elevated conductors which couples or matches the transmitter or receiver to free space. A transmitting antenna connecting to a transmitter by transmission line, forces electromagnetic waves in to free space which travel in space with velocity of light.

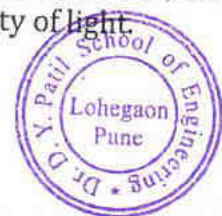

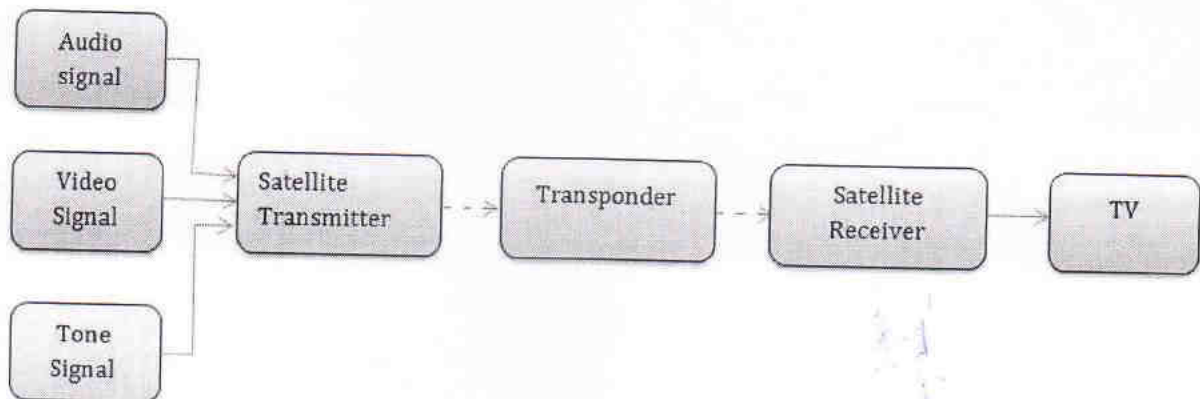

**Procedure:**

1. Connect the satellite uplink transmitter to AC mains.
2. Switch on the transmitter by mains switch and frequency.
3. The transmitting frequency can be selected by knob. The frequency can be changed from 2390-2468 -2490-2510 MHz.
4. The transmitter on-off switch will switch on -off the transmission.
5. Connect the satellite downlink receiver to AC mains.
6. Switch on the receiver by mains switch.
7. The receiving frequency can be selected by knob. The frequency can be changed from 2390-2468 -2490-2510 MHz.
8. Select a downlink frequency which is less than uplink frequency.
9. Switch on the transponder by mains switch.
10. The transmitting frequency & receiving frequency can be selected by knob. The frequency can be changed from 2390-2468 -2490-2510 MHz.
11. Connect the Audio/Video signal at the input socket provided on the Uplink Transmitter, Video at video input and audio at audio in input
12. connect tone signal input socket onboard uplink Transmitter by patch cord.
13. Connect TV monitor to the Audio/Video o/p of downlink receiver. Set TV in AV



Dr. D. Y. Patil Group of Institutions' Technical Campus  
**Dr. D. Y. PATIL SCHOOL OF ENGINEERING**  
Dr. D. Y. Patil Knowledge City, Charholi Bk., Via. Lohegaon, Pune - 412 105.  
Department of **Electronics and Telecommunication Engineering**

Mode.

14. The TV monitor will display video and audio signal that you have connected to uplink transmitter input, also you can hear a tone signal through speaker.

**Conclusion:**





## Experiment No. 10

### **To transmit and receive PC data through satellite link**

**Aim:-** To transmit and receive PC data through satellite link

**Apparatus:-** Satellite Transmitter, Satellite Transponder, Satellite Receiver, connecting cords, antennas, Computers, RS-232 cables.

### **Theory:**

#### **Uplink Transmitter:**

In uplink station the signal has to be sent at a different frequency usually in higher 1GHz band to avoid interference with link signal. Another function performed by uplink station is to control highly internal function of satellite. up links are controlled so that transmitted micro wave beam is extremely narrow in order not to interface with adjacent satellite.

#### **Transponder:**

Each satellite has a number of transponder with access to a pair of receive / transmit antennas and associated electronics for each channel. For example in Europe the uplink sends a signal at a frequency of about 14 GHz. These are received downlink converted in frequency of about 11/ 12 GHz and boosted by high power amplifier for retransmission to earth. Separate transponders are used for each channel and are powered by solar panels with backup batteries for eclipse protection.

#### **Down Link Receiver:**

The medium used to transmit signal from satellite to earth is microwave electromagnetic radiation which is much higher in frequency normal broadcast TV signal in VHF / UHF bands. Microwave still exhibit a wave like nature, but inherit a tendency to serve attenuation by water vapors or any obstruction in line of sight of antenna. The transmitted micro wave power is extremely weak by the time it reaches earth and unless well designed equipment is used and certain installation precaution are taken, the background noise can ruin the signal.

#### **Antenna:**

To radiate or receive electromagnetic waves an antenna is required. Antenna is system of elevated conductors which couples or matches the transmitter or receiver to free space. A transmitting antenna connecting to a transmitter by transmission line, forces electromagnetic waves in to free space which travel in space with velocity of light.





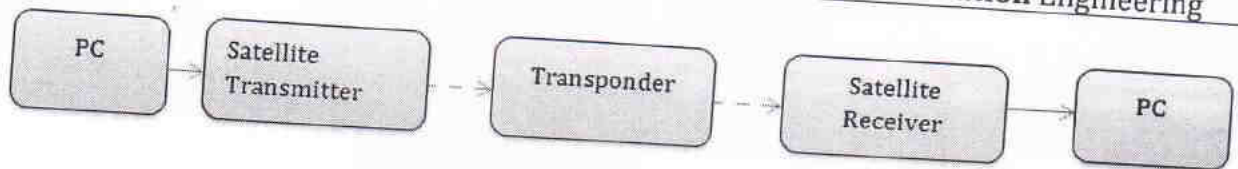

Fig.1. Block diagram of satellite link

**PROCEDURE:-**

1. Connect the satellite uplink transmitter to AC mains.
2. Switch on the transmitter by mains switch .The transmitting frequency can be selected by knob. The frequency can be changed from 2390-2468 -2490-2510 MHz.
3. The transmitter on -off switch will switch on -off the transmission.
4. Connect the satellite downlink receiver to AC mains.
5. Switch on the receiver by mains switch .
6. The receiving frequency can be selected by knob. The frequency can be changed from 2390-2468 -2490-2510 MHz.
7. Select a downlink frequency which is less than uplink frequency.
8. Switch on the transponder by mains switch .
9. Connect RS -232 cable from uplink transmitter to one set of PC.
10. Connect RS -232 cable from downlink receiver to one set of PC.
11. Switch on the PC and install sat. Software on both PC and select communication port COM 1 on both PC.
12. When the link is established, the typed matter on first set up PC will be transmitted to second set up PC via. Satellite link.

**Conclusion: -**

## Index

Sr. No.	Name of Experiment/Assignment	Page No.
1	Test on Gear/Vane/Piston pump and plotting performance characteristics	2
2	Following experiments to be done on hydraulic trainer a) Regenerative circuit b) Speed control circuit c) Sequencing circuit d) Traverse and feed circuit etc.	7
3	Following experiments to be done on pneumatic trainer (any 3) a) Automatic reciprocating circuit b) Speed control circuit c) Pneumatic circuit involving Shuttle valve/ Quick exhaust valve / Two pressure valve d) Electro pneumatic circuits	13
4	Test on pressure relief valve/flow control valve	16
5	Test on linear /rotary actuator	18
6	Design of simple hydraulic systems used in practice using manufacturers' catalogue and analysis using software such as Automation Studio.	21
7	Design of simple pneumatic systems used in practice using manufacturers' catalogue and analysis using software such as Automation Studio.	25
8	Industrial visit to study Hydraulic / Pneumatic based Automation systems	-



## EXPERIMENT NO. 1

### Trial on Gear Pump and Plotting Of Performance Characteristics

**Aim:** To conduct test on Gear Pump and plotting performance characteristics.

**Apparatus:** Gear pump with electric motor, pressure relief valve, control valve, reservoir, measuring tank with scale, pressure gauge and vacuum gauge.

**Theory:**

#### External Gear Pump

The operation of an external gear pump, which develops flow by carrying fluid between the teeth of two meshing gears, is shown in the figure 2.1. One of the gears is connected to a drive shaft connected to the prime mover. The second gear is driven as it meshes with the driver gear. Oil chambers are formed between the gear teeth, the pump housing and the side wear plates. The suction side is where teeth come out of the mesh and it is here that the volume expands, bringing about a reduction in pressure below atmospheric pressure. Fluid is pushed into this void by atmospheric pressure because the oil supply tank is vented to the atmosphere. The discharge side is where teeth go into mesh and it is here that the volume decreases between mating teeth. Since the pump has a positive internal seal against leakage, the oil is positively ejected into the outlet port.

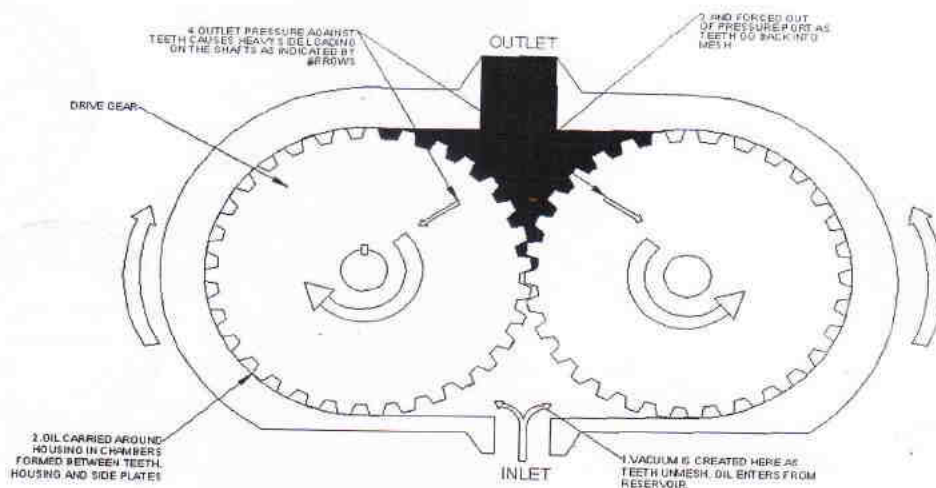

**Figure 1.1: External Gear Pump**

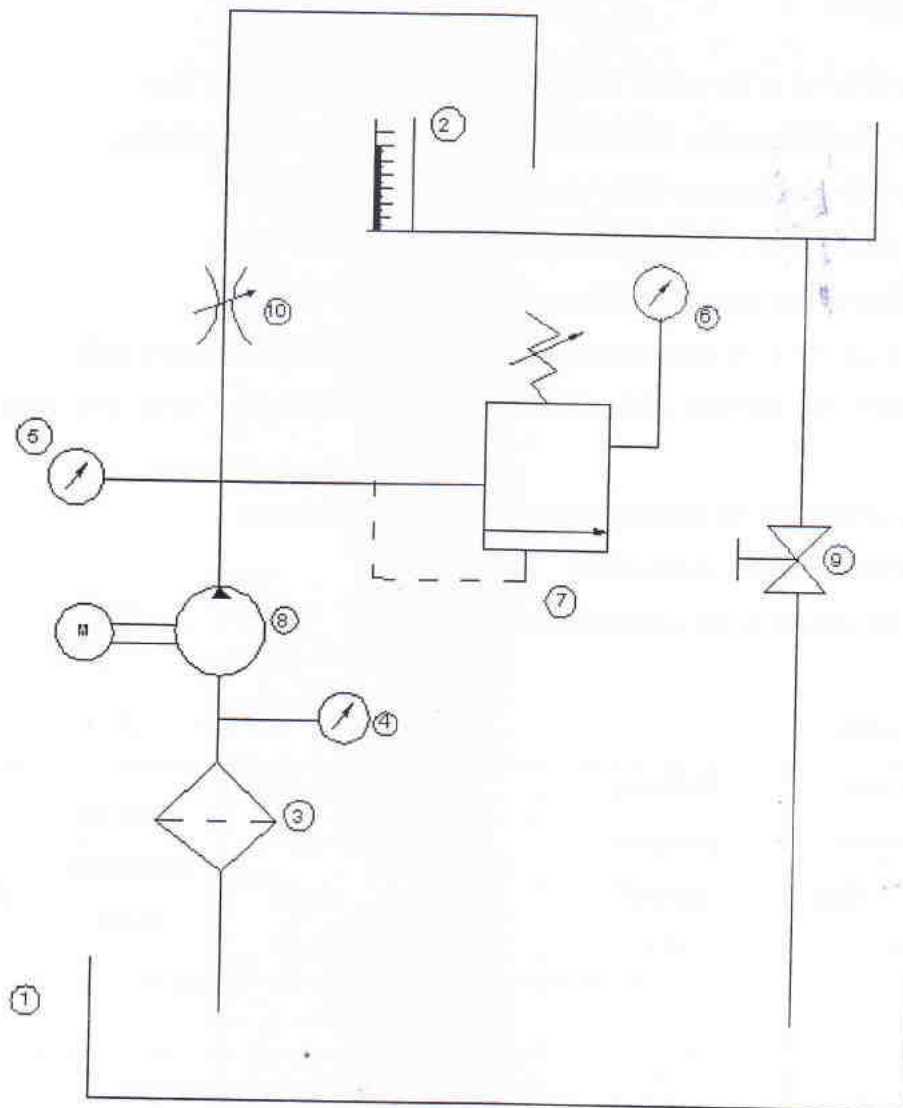

- |                   |                          |
|-------------------|--------------------------|
| 1. Reservoir tank | 7. Pressure relief valve |
| 2. Measuring tank | 8. Pump                  |
| 3. Filter         | 9. Shut off valve        |
| 4. Vacuum Gauge   | 10. Control valve        |
| 5. Pressure Gauge | M - Motor                |
| 6. Pressure Gauge |                          |

**Figure 1.2 Hydraulic Setup for Gear Pump**



**Operation procedure:**

1. Check the oil level in the sump. Initially the bypass valve must be open.
2. Switch on the main supply. Let the system run for 2-3 min for stabilizing.
3. Adjust the delivery pressure using pressure regulating valve.
4. Close the drain valve of the measuring tank; level will start rising.
5. Note the readings as per observation table.
6. Open the drain valve of measuring tank for draining the oil in the sump tank.
7. Again adjust the delivery pressure using pressure regulating valve and note down the readings.
8. Repeat the procedure for different settings of delivery pressure.
9. Switch off the electrical connections.
10. Calculate the results as per calculation procedures.

**Observation table**

Sr No.	Suction pressure (mm of Hg) [P <sub>1</sub> ]	Delivery pressure (kg/cm <sup>2</sup> ) [P <sub>2</sub> ]	Rise level (mm)	Time for 5 cm rise in level (sec)	Time for 10 flashes (sec)	PRV (kg/cm <sup>2</sup> )
1						
2						
3						
4						
5						



*Hydraulic & Pneumatics (BE, 2015 Course)*  
*Laboratory Manual*

$$g = 9.81 \text{ m/s}^2$$

Hence, output power =

$$\text{Pump efficiency} = [\text{Pump output} / \text{Driving motor input}] * 100$$

**Result table:**

Sr. No.	Suction head Hs (m)	Delivery head Hd (m)	Actual discharge (m <sup>3</sup> /s)* 10 <sup>-4</sup>	Total head (Water) (m)	Total head (oil) (m)	Output power (kW)	Input power (kW)	Efficiency (%)
1								
2								
3								
4								
5								
6								

**Conclusion:**

1. From the graph of discharge vs head it can be seen that discharge is constant for increasing head but after some period it decreases due to increased leakage loss.
2. From the graph of efficiency vs head, efficiency increases for increasing head.
3. From the graph of input power vs head, discharge head increases the input power required to drive the pump.



*Hydraulic & Pneumatics (BE, 2015 Course)*  
*Laboratory Manual*

**Sample Calculations**

For power input,

$$\text{Input power} = (3600 \times n) / (k \times t)$$

Where

n = actual flashes during time 't'

k = energy meter constant (flashes/kWhr)

Considering motor efficiency,

Input power =

**To find Q:**

Volume of the tank = (Area of the tank X height of the tank)

Volume of the tank =

Q = Volume of the tank / Time

t = time for 5 cm rise in tank

**Total head (H):**

$$H = H_s + H_d$$

Where,

$H_s$  = Suction head

$$= (P \times 13.6) / 1000 \quad \text{m of water}$$

=

$H_d$  = Delivery head

$$= (P \times 10) \text{ m of water}$$

Total head =  $H_s + H_d$

$$\text{Output power} = (\rho \times g \times Q \times H) * 10^{-3}$$

Where  $\rho = 875 \text{ kg/m}^3$



## Experiment No 2

**Aim:** To study regenerative, speed control, sequence and transverse feed circuit.

**Theory:**

### 1) Regenerative circuit

Figure 1 shows a regenerative circuit that automatically switches off regeneration when full force is necessary. This circuit could be used in a hydraulic press where the cylinder must extend quickly under no load, then bottoms out and must apply full force to the work piece. Instead of using a four-way with a regenerative neutral, this circuit uses a four-way DCV in conjunction with a three-way, pilot-operated DCV. The three-way valve is shifted when sufficient pressure is applied to its pilot line, which is connected to the blind end of the cylinder. In the figure, the four-way valve is shifted to the left position and flow is sent to the blind end of the cylinder. Because the cylinder is not loaded, the pressure in the blind end is very low and is not sufficient to shift the three-way valve. The flow from the rod end combines with the pump flow, causing the cylinder to extend rapidly. When the cylinder bottoms out, pressure immediately builds up in the blind end line to the relief valve setting because there is no other path for pump flow. The three-way valve is then shifted into the left position and pressure is relieved from the rod side because it is connected to the tank port. The pressure is then applied to the blind side that causes full force to be applied to the work piece. When the four-way DCV is shifted into the right position, the cylinder retracts at a normal speed. In this circuit, the reduction in force capability caused by regeneration is not an issue because during the regeneration portion of the cycle, the cylinder is not loaded. The primary advantage of using regeneration is that a smaller pump can be purchased that is less expensive to buy and operate.





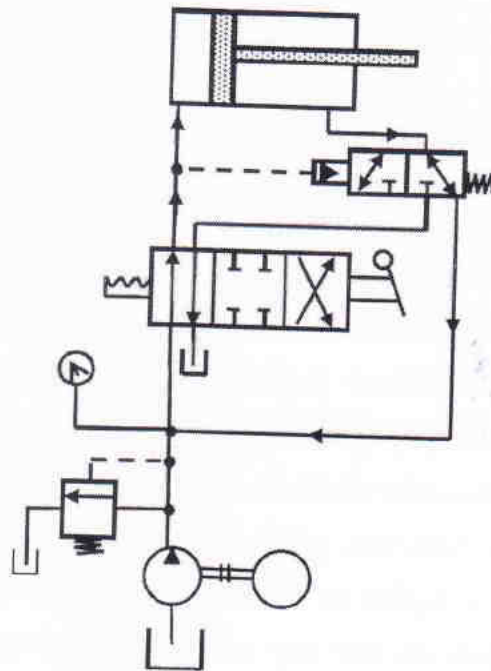

**Fig.2.1 Regenerative circuit**

## 2) Speed control unit

In hydraulic operations, it is necessary to control the speed of the actuator so as to control the force, power, timing and other factors of the operation. Actuator speed control is achieved by controlling the rate of flow into or out of the cylinder.

Speed control by controlling the rate of flow into the cylinder is called meter-in control. Speed control by controlling the rate of flow out of the cylinder is called meter-out control.

### A) Meter-in flow control system:

Figure 2 shows a meter-in circuit with control of extend stroke. The inlet flow into the cylinder is controlled using a flow-control valve. In the return stroke, however, the fluid can bypass the needle valve and flow through the check valve and hence the return speed is not controlled. This implies that the extending speed of the cylinder is controlled whereas the retracing speed is not.

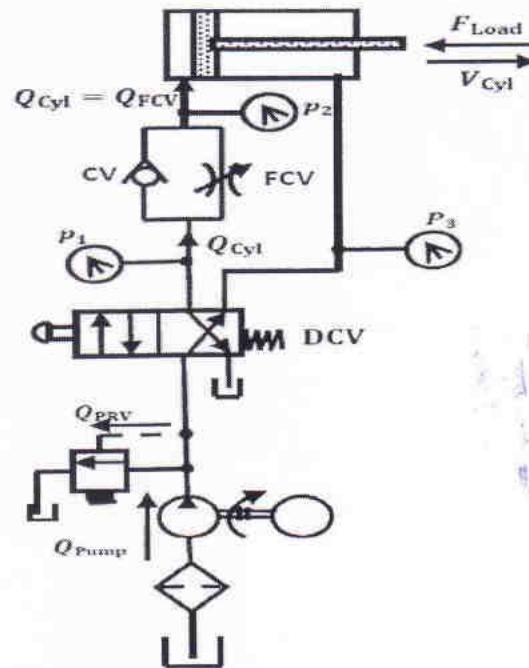

Fig.2.2 Meter in flow circuit

**B) Meter-out flow control system:**

Figure 3 shows a meter-out circuit for flow control during the extend stroke. When the cylinder extends, the flow coming from the pump into the cylinder is not controlled directly. However, the flow out of the cylinder is controlled using the flow-control valve (metering orifice). On the other hand, when the cylinder retracts, the flow passes through the check valve unopposed, bypassing the needle valve. Thus, only the speed during the extend stroke is controlled.

Both the meter-in and meter-out circuits mentioned above perform the same operation (control the speed of the extending stroke of the piston), even though the processes are exactly opposite to one another.



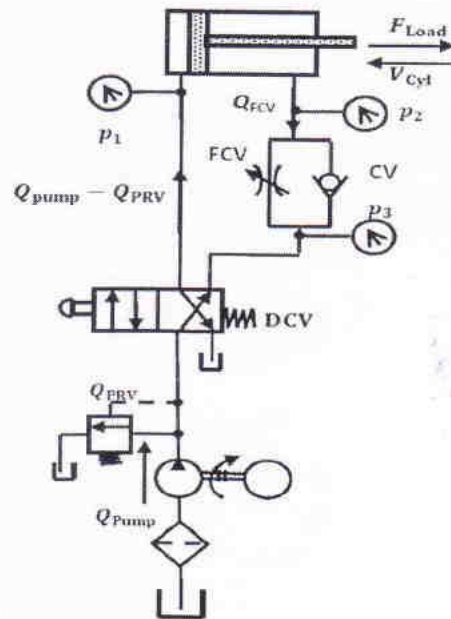

Fig.2.3 Meter out circuits

3) Sequencing circuit:

The hydraulic circuit shown in Fig. is an example of an application of a sequence valve in which a clamp cylinder extends first to hold a work piece and then a second cylinder extends to bend the work piece in the desired shape.

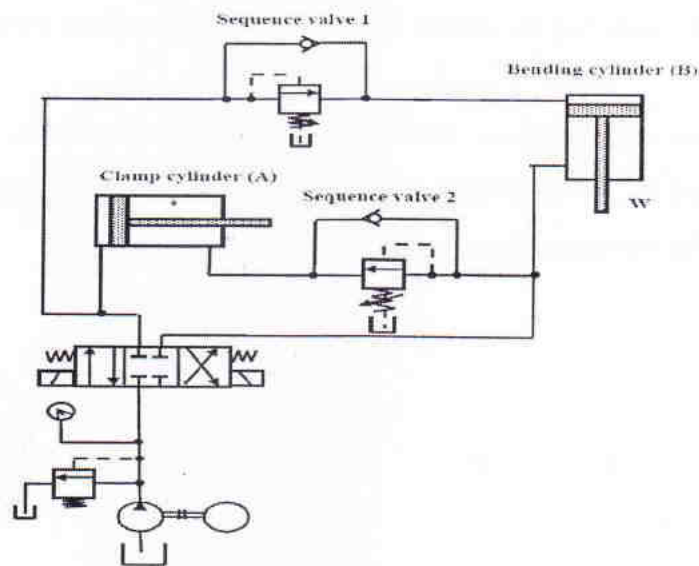

Fig.2.4 sequencing circuit



*Hydraulic & Pneumatics (BE, 2015 Course)*  
*Laboratory Manual*

In this circuit, two cylinders are connected in parallel. Without the sequence valve, these cylinders would extend together as they are both unloaded. In order for this circuit to function properly, the clamp cylinder must extend completely before the bending cylinder begins to extend. The sequence valve accomplishes this by not allowing flow into the bending cylinder branch of circuit until the clamp cylinder has reached the end of its stroke. When the clamp cylinder extends completely, the pressure rises and opens the sequence valve, thus allowing the bending cylinder to extend. The sequence valve must be set high enough so that it opens only after the complete extension of the clamp cylinder.

During the retraction of cylinders, the check valve allows the sequence valve to be bypassed. The sequence valve has no effect on the circuit in this situation. Both cylinders retract together because both are unloaded and split the pump flow.

**Transverse and feed circuits:**

Circuit for Fast Approach and Slow Die Closing A machine intended for high volume production has a high piston velocity. If not controlled, the high-speed platen approaching the job instead of making a smooth contact will bang on the job. This is not desirable. In all such cases, "rapid transverse and feed circuits" are employed. Pump delivery normally passes through FCV (3). During fast approach, the solenoid-operated DCV (4) is energized. This diverts pump delivery to the cap end of the cylinder through valve (4). Full flow is thus available for the actuator to advance at the rated speed. A few millimeters before the platen makes contact with the die, solenoid valve (4) is de-energized forcing the pump delivery to pass through FCV (3). The platen now approaches the die at a controlled speed because the flow to cylinder (6) is now regulated. Directional valves (4) and (5), however, must be energized simultaneously for the approach phase to begin.



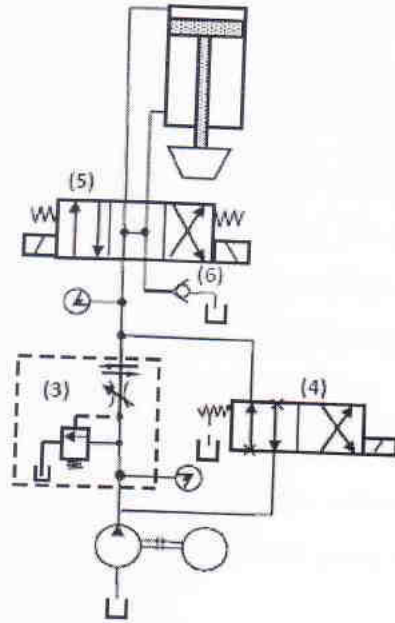

**Fig.2.5 Transverse and feed circuit**



## Experiment No. 3

### Pneumatic trainer

**Aim:** - To study pneumatic circuits.

1. Automatic reciprocating circuit.
2. Speed control circuit.
3. Pneumatic circuit involving quick exhaust valve.
4. Electro – Pneumatic valves and circuit.

**Theory:- 1. Automatic reciprocating circuit:**

Depending on various tools jigs and fixtures, the cylinder and circuit has to be operated in particular sequence. Fig shows a circuit in which a double acting cylinder (DCV) reciprocating automatically when actuating signal is given to push button operated 3/2 DC valve as shown in fig. allows desired motion forward by valve and backward . Various modes of pneumatic circuit help to determine desired sequencing of cylinder moment sequencing could be achieved mechanically or electro-pneumatically by distributing and transmitting signals from a no. of pilot valves which may be actuated by spring action then inline off motion of piston rod in pneumatic system.

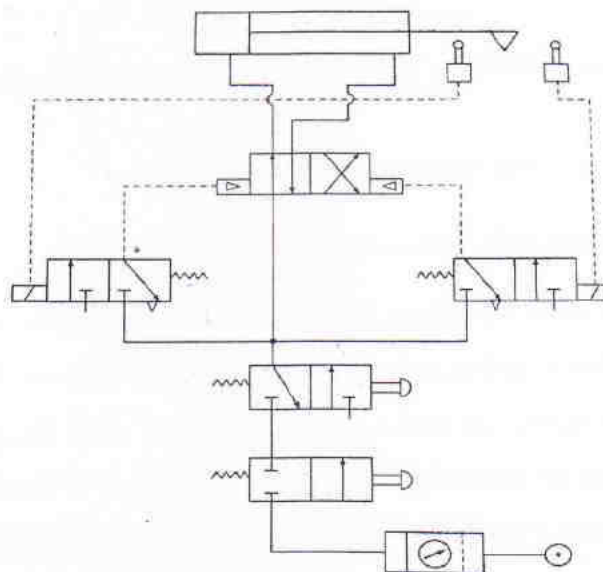
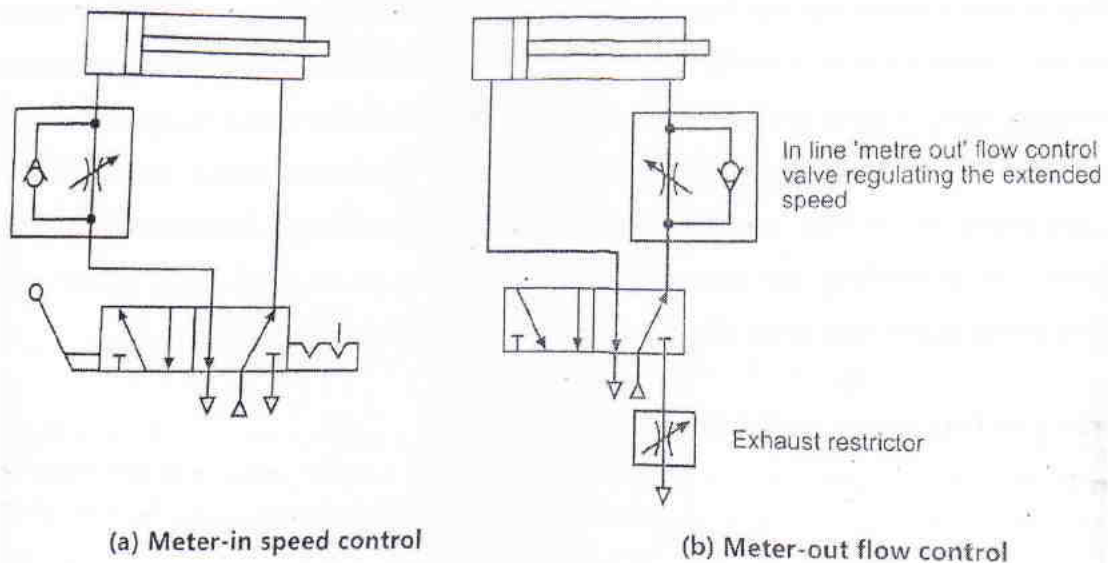

**Fig. 3.1 Automatic reciprocating circuit**



**2. Speed control circuit:**

The velocity of the pneumatic cylinders or motors depends on the volume of the air entering and leaving the cylinder. But air is compressible fluid. Hence volume of the given mass of air changes with temperature and pressure. Temperature variation across the actuator system is small and its effect is neglected. The effect of pressure can vary as the load and flow rate changes. For control of speed of actuators either the quantity entering the piston side is controlled (meter in). For this purpose, flow control valve and check valve (to permit free flow in the other direction where air flow is not controlled) are used.



**Fig. 3.2 Speed Control Circuits**

**3. Pneumatic circuit involving quick exhaust valve:**

The quick exhaust valve is used to exhaust the cylinder air quickly to atmosphere. Schematic diagram of quick exhaust valve is shown in Figure 1. In many applications, it is a common practice to increase the piston speed during retraction of the cylinder to save the cycle time. The higher speed of the piston is possible by reducing the resistance to flow of the exhausting air during the motion of cylinder. The resistance can be reduced by expelling the exhausting air to the atmosphere quickly by using Quick exhaust valve. Typical applications of quick exhaust valves for single acting and double acting cylinders are shown in Figure 2.



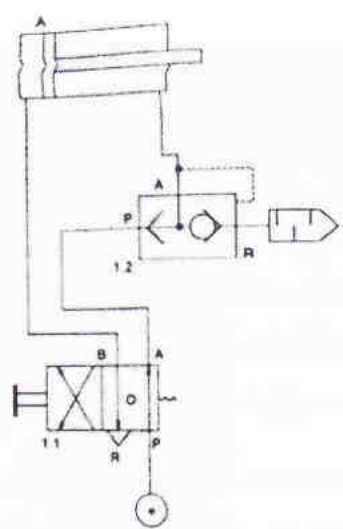

Fig. 7.12 Use of quick exhaust valve: A—D.A. cylinder 1.1 4/2 D.C. valve 1.2 Quick exhaust valve

Fig.2. Application of Quick Exhaust Valve.





## Experiment No.4

**Aim:** Test on Pressure relief valve

**Construction and operation:**

The mostly widely used type of pressure control valve is the pressure relief valve (PRV), since it is found in practically every hydraulic system. It is normally a closed valve whose function is to limit the pressure to a specified maximum value by diverting pump flow back to the tank.

Fig. 1-a&1-b shows the operation of a simple relief valve. A poppet is held seated inside the valve by the force of a stiff compression spring. When the system pressure reaches to a high enough value, the resulting hydraulic force (acting on the piston-shaped poppet) exceeds the spring force and the poppet is forced off its seat. This permits flow through the outlet to the tank as long as this high pressure is maintained. Note the external adjusting screw, which varies the spring force and thus the pressure at which the valve begins to open (cracking pressure). Fig.(1-b) also shows the graphic symbol of a simple PRV.

It should be noted that poppet must open sufficiently to allow full pump flow. The pressure that exists at full pump flow can be substantially greater than the cracking pressure. This is shown in Fig 2, where system pressure is plotted versus flow through the relief valve. The stiffness of the spring (force required to compress the spring 1 in or 1 cm) and the amount poppet must open to permit full pump flow determine the difference between full pump flow pressure and the cracking pressure. The stiffness of the spring is called a spring constant and has a unit of 1 lb/in or 1 N/cm. The pressure at full pump flow is the pressure level that is specified when referring to pressure setting of the relief valve. It is the maximum pressure level permitted by the relief valve.



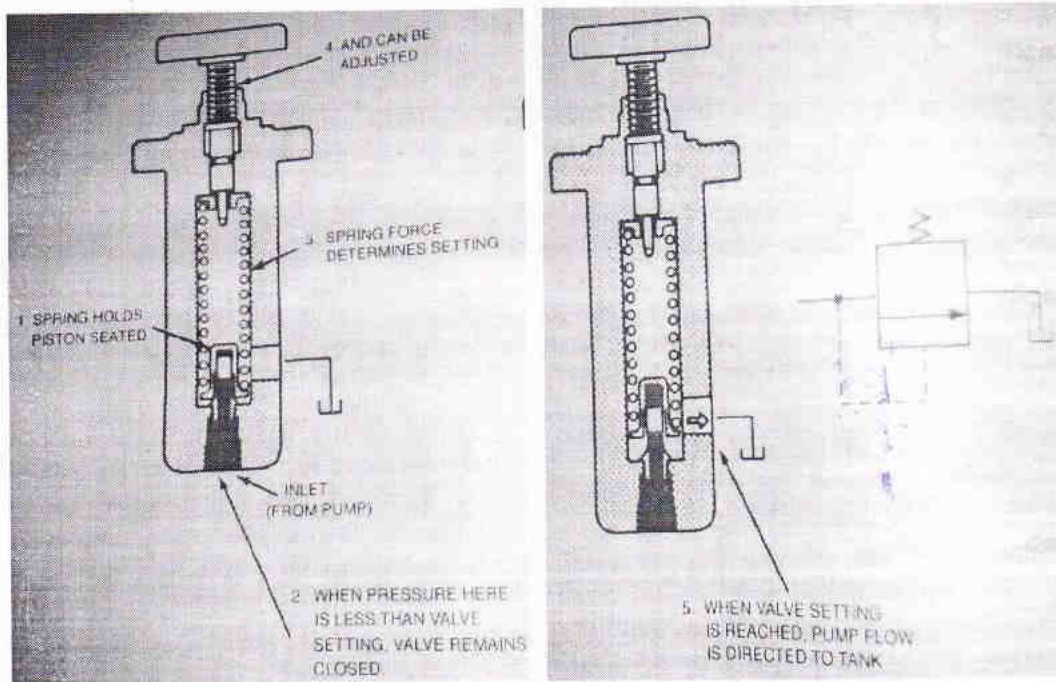

Fig 4.1 Pressure Relief Valve

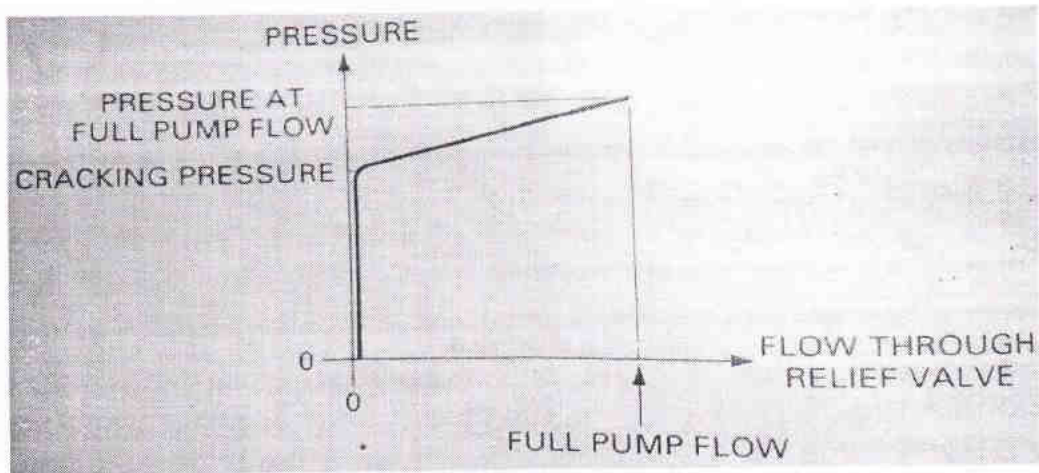

Fig 2

**Conclusion:**

The pressure relief valve characteristics are verified.



### Experiment No.5

**Aim:** To Study of Basic pneumatic circuit for the working of single and double acting cylinder

**Apparatus:** - Air tank, filter, compressor, junction box, manually operated, 2x3 D.C. valve single acting cylinder, double acting cylinder, pipes,

**Circuit Diagram:**

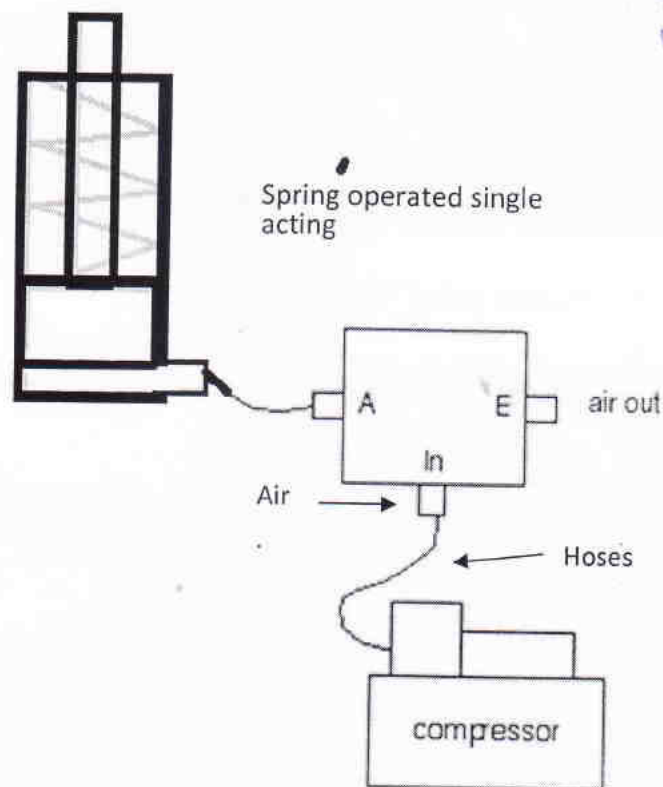

**Fig 4.1 – Schematic sketch Single acting pneumatic cylinder**



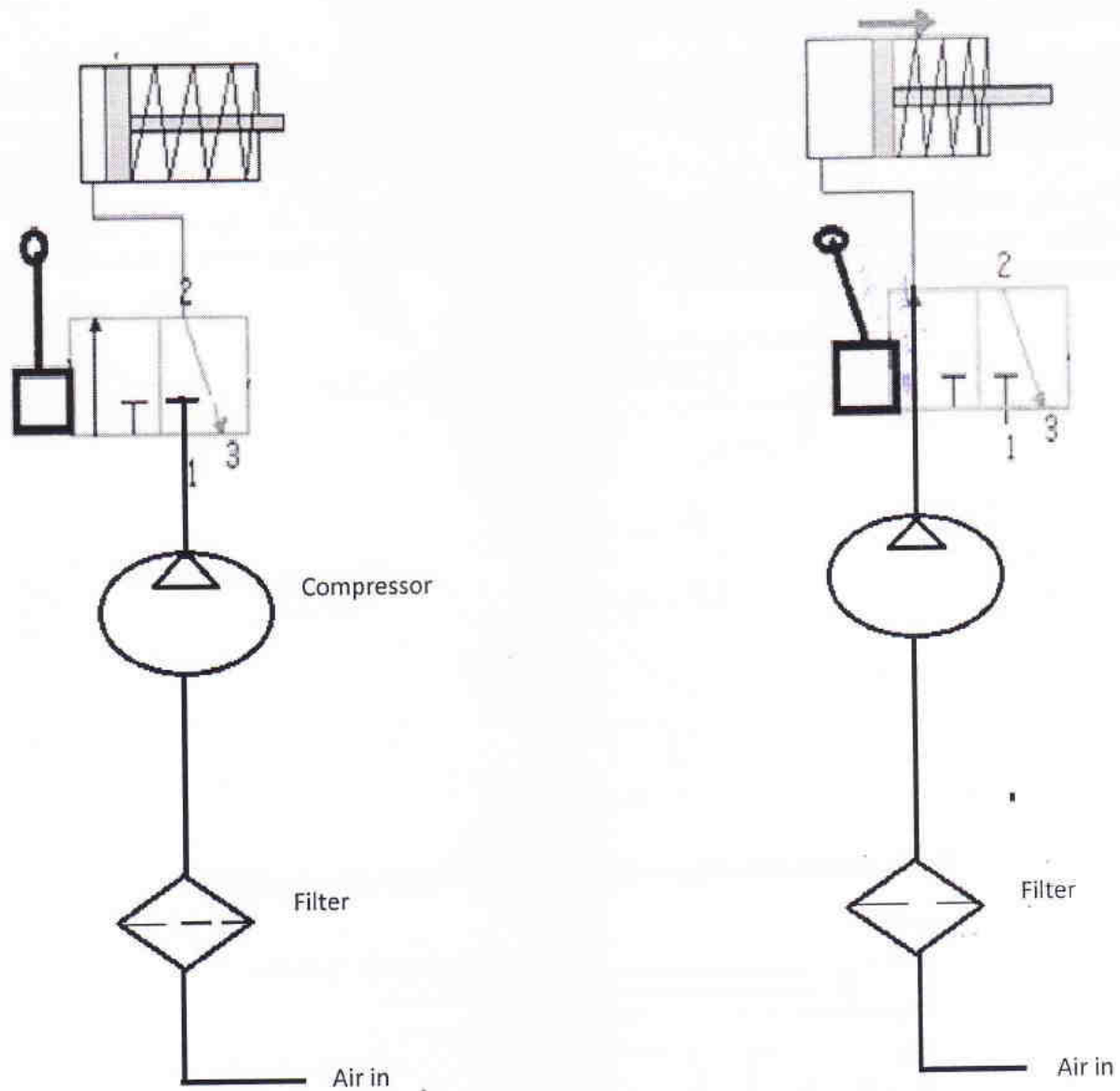

**A**      **Fig 4.2 Working of single acting cylinder operation**      **B**

**Theory**

Connect all components as per above shown fig. high pressurized air enters in 3X2 Valve manually forward positions of lever air enters in cylinder,  
 When lever operated backward the air exhausted in surrounding through port E due to force of compressed spring



**Forward motion** Due to pressurized air enters in cylinder.

**Backward motion**- spring pressure applied on area of piston surface

A) In fig. there is return movement of piston due to spring force. So air is delivered (exhausted) to atmosphere. Here 3x2 direction control valve is used. The air is exhausted to atmosphere through port 2 to 3.

B) In fig. there is forward movement of piston due to high pressure air. So air is entered to cylinder. And apply the force on piston surface Here 3x2 direction control valve is used. The air is entered in cylinder through port 1 to 2.

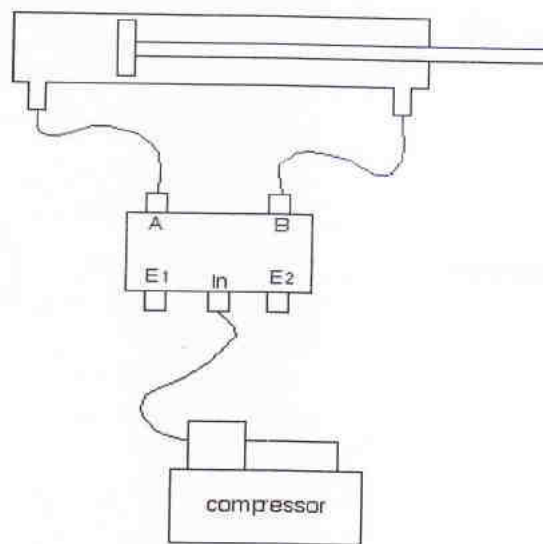

Fig. 4.3 schematic diagram of double acting pneumatic cylinder

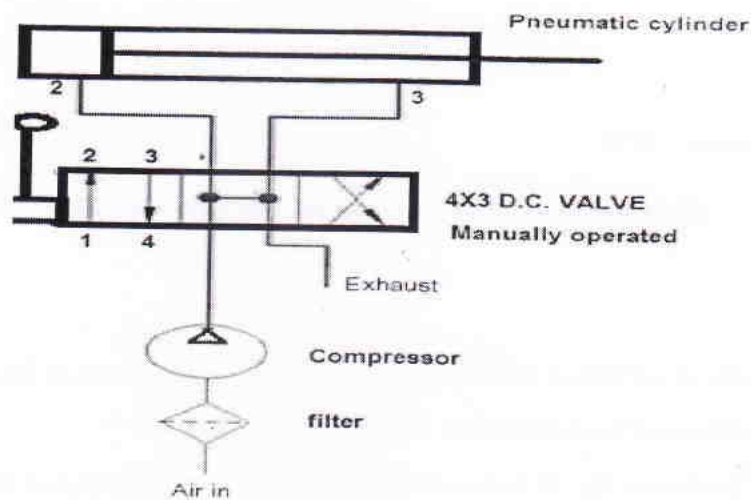

Fig. 4.4 schematic diagram of double acting pneumatic cylinder



*Hydraulic & Pneumatics (BE, 2015 Course)*  
*Laboratory Manual*

**Theory:**

In above pneumatic circuit we have used 4x3 D.C. valves. The valve is having four ports Port 1 is connected to compressor  
Port 3 is relieved to atmosphere through muffler.  
Port 4 & 2 are connected to pneumatic cylinder  
Forward position - At forward movement of piston, port 1 is connected to port 4 and port 2 is connected to port 3  
Retract position - At reverse movement of piston, port 1 is connected to port 2 and port 4 is connected to port 3

**Procedure**

- 1] Switch on the compressor to store high pressure air.
- 2] Connect the pipes as per circuit shown above.
- 3] Connect air reservoir to junction box
- 4] Check pressure level in tank to be full shown by indicator
- 5] Observe the reciprocating motion of Single acting and double acting cylinder.
- 6] Observe the rotary motion of hydraulic motor.

**Applications-** used in industries for fitting the component of job.



## EXPERIMENT NO. 6

### DESIGN OF SIMPLE HYDRAULIC SYSTEM

**AIM:** Study of simple hydraulic system

#### Hydraulic press circuit

The press circuit is shown in figure. The application of these valves, counter balance valve 'C' receives its signal from a point within counter balance valve structure. Valve 'c' is shown externally drained. It can be internally drained if there is to be no resistance on the cylinder line where when the flow is directed /diverted to the tank. If there is a question as to the amount of back pressure that may be encountered it is safest to provide an external drain.

Valve 'D' in figure is a sequence valve. The signal is taken from ahead of the valve and is picked up within the valve envelope. The drain in this valve must be independently connected to the tank because there will be pressure exerted on the discharge of the valve.

Valve 'E' is used in the circuit as an unloading valve. It will be externally piloted and externally drained if there is any resistance the return to the tank port. If needle valve 'K' were on the upstream side of valve 'E', the latter could be internally drained. With valve 'K' on the downstream side as shown in figure spig pocket must be externally drained so that back pressure does not provide an additive pressure to the spring. The needle valve in conjunction with unloading valve established the amount of two flow necessary to decompress the pressure in the proper time interval.

A safety valve 'G' is used at the rod end of the jack ram to avoid accidental intensification of pressure. The variable delivery pump has a pressure compensator to short stroke the pump. The pump provides pressurized fluid for the circuit. Full flow volume is available for rapid pressure movement. The pressure compensated short-strokes the pump when a desired maximum pressure is attained.

Valve 'A' is safety valve in functions only if the pump compensating mechanism fails. This valve would be adjusted to pressure value about 20% higher than that established by the pump limiting mechanism. Valve 'B' is directional control valve. It is solenoid control valve,



*Hydraulic & Pneumatics (BE, 2015 Course)*  
*Laboratory Manual*

hydraulic actuated unit. When side 1 is actuated it direct fluid to the head end of the small pilot cylinders or jack ram. Valve 'D' will prevent fluid flow into main ram until certain minimum pressure is reached. The centre block of the descriptive symbol of valve 'B' shows that the cylinder lines to the main ram and jack rams are connected together in neutral position of the valve. The pressure port is blocked in neutral. Lines into block to left indicate that as side 1 directs pressure source to main ram and head end of jack rams, the fluid from rod end of jack ram is directed to reservoir through counter balance valve 'C'.

The valve spool 'B' is used to block the ports in neutral, the weight of main ram and platens can cause the machine to close to fast and damage the machine parts when valve 'B' is shifted further. If spool in 'B' were to develop a slight leak, there might be undesirable movement of machine members. For this reason, it is usual to relax the fluid to both, top and bottom of main cylinder and hold the ram in position with counter balance valve as shown top the circuit position of valve 'C'.

If for any reason, valve 'C' is failed to open, fluid will be locked within rod end of the jack ram. The resistance caused by the blocked fluid would cause supply fluid to open a path through valve 'D' and full force would be exerted on the main ram.

When the platens meet and resistance cause rise in fluid pressure, in flow from pump diverted through valve 'D' at its set value and full pressure will effect on both jack rams and main ram. Full tonnage will be then provided between platens. Next, the compensator on the ump establishes maximum pressure and pressure 'H' and pressure 'H' creates a signal at pressure value somewhat less than the maximum value created by the pump control. The signal from pressure switch 'H' will start a timer that times out at predetermined period. This de-energizes side 1 of valve 'B' and activated side 2. Fluid is directed to side 2 to rod side of the jack rams through check valve around valve 'C'. This check valve may build integral with valve 'C'.

The pressure opens valve 'E', a relatively small two way valve, that allows all stresses of the pressure to be relieved and pressure to drop to low value. After this decompression, pilot pressure opens pilot check valve 'J' and permits fluid to exhaust from main ram. At this time, the platen can rise and to open to pressure, ready for unloading and reloading. When platen reaches upper level of travel, it connects a limit switch, electric eye or some other sensing device that





*Hydraulic & Pneumatics (BE, 2015 Course)*  
*Laboratory Manual*

cause solenoid on directional control valve to de-energize. De-energizing solenoid causes platen to stop its upward travel.

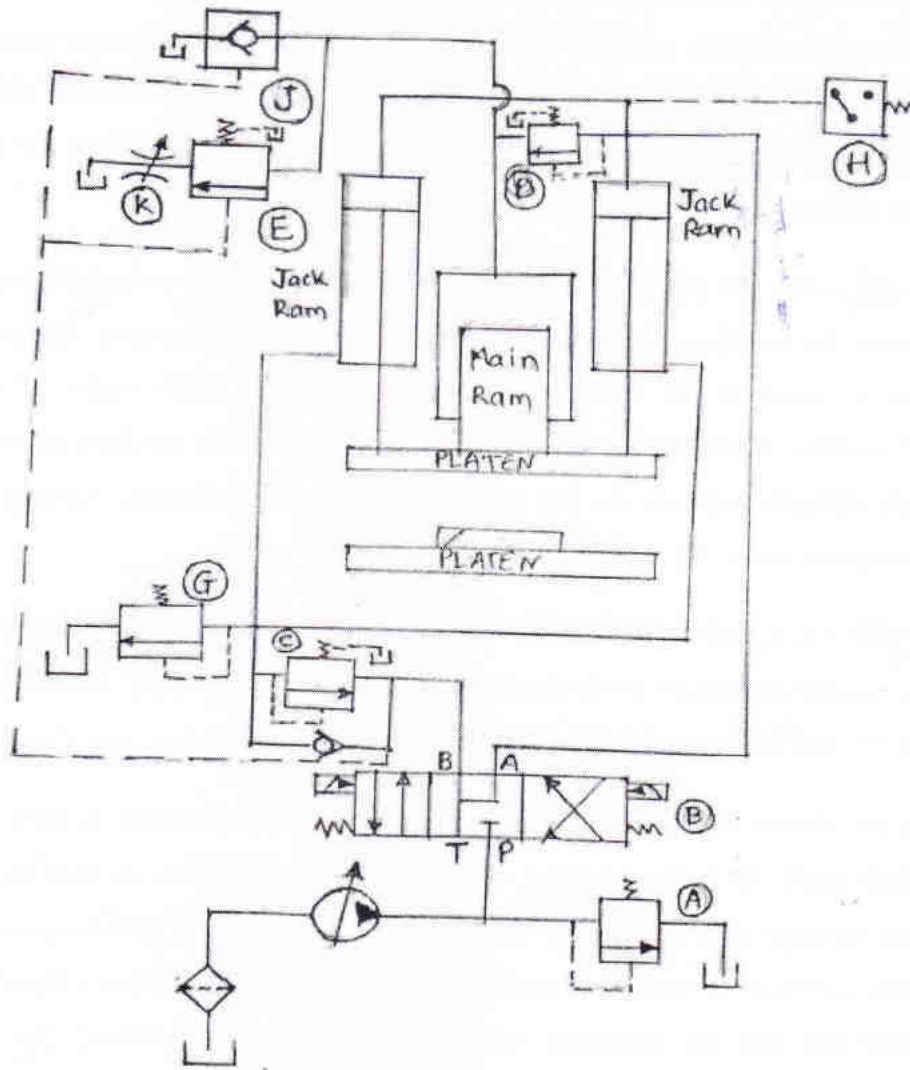

Fig. 6.1 Hydraulic Press

- A=Pressure Relief Valve    B= 4/3 Direction Control Valve    C= Counter Balance Valve  
 D= Sequence Valve    E= Unloading Valve    G= Safety Valve  
 H= Pressure switch    J= Pilot operated check valve  
 K= Flow Control Valve.



## **Experiment No. 7**

### **Design of simple pneumatic system**

**Aim:** Study of simple pneumatic systems used in practice such as Braking system, vibrators, drilling, chisels etc

**Theory:**

Pneumatics is a section of technology that deals with the study and application of pressurized gas to produce mechanical motion. Pneumatic systems, that are used extensively in industries, and factories, are commonly plumbed with compressed air or compressed inert gases. This is because a centrally located and electrically powered compressor, that powers cylinders and other pneumatic devices through solenoid valves, can often provide motive power in a cheaper, safer, more flexible, and more reliable way than a large number of electric motors and actuators. Pneumatics also has applications in dentistry, construction, mining, and other areas.

**(a) The advantages of pneumatic systems**

Pneumatic control systems are widely used in our society, especially in the industrial sectors for the driving of automatic machines. Pneumatic systems have a lot of advantages.

(i) High effectiveness (ii) High durability and reliability (iii) Simple design (iv) High adaptability to harsh environment (v) Safety (vi) Easy selection of speed and pressure (vii) Environmental friendly (viii) Economical

**(b) Limitations of pneumatic systems**

Although pneumatic systems possess a lot of advantages, they are also subject to many limitations.

(i) Relatively low accuracy (ii) Low loading (iii) Processing required before use

(iv) Un-even moving speed (v) Noise

**Principles of pneumatic control**

**(a) Pneumatic circuit**



*Hydraulic & Pneumatics (BE, 2015 Course)*  
*Laboratory Manual*

Pneumatic control systems can be designed in the form of pneumatic circuits. A pneumatic circuit is formed by various pneumatic components, such as cylinders, directional control valves, flow control valves, etc. Pneumatic circuits have the following functions:

1. To control the injection and release of compressed air in the cylinders.
2. To use one valve to control another valve.

**(b) Pneumatic circuit diagram**

A pneumatic circuit diagram uses pneumatic symbols to describe its design. Some basic rules must be followed when drawing pneumatic diagrams.

**Case Study: Pneumatic system used in Drilling:**

Fig. 1 shows the schematic representation of actually operation of drilling. In this the actuation sequence followed is A+, B+, A-, B-.

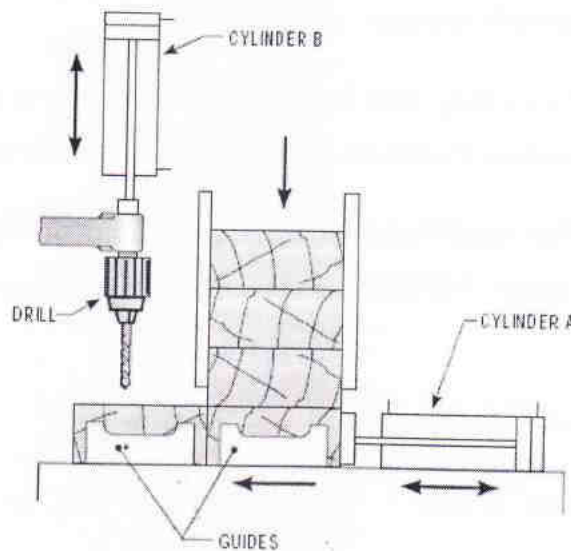

**Fig.7.1: Typical Pneumatic Circuit**

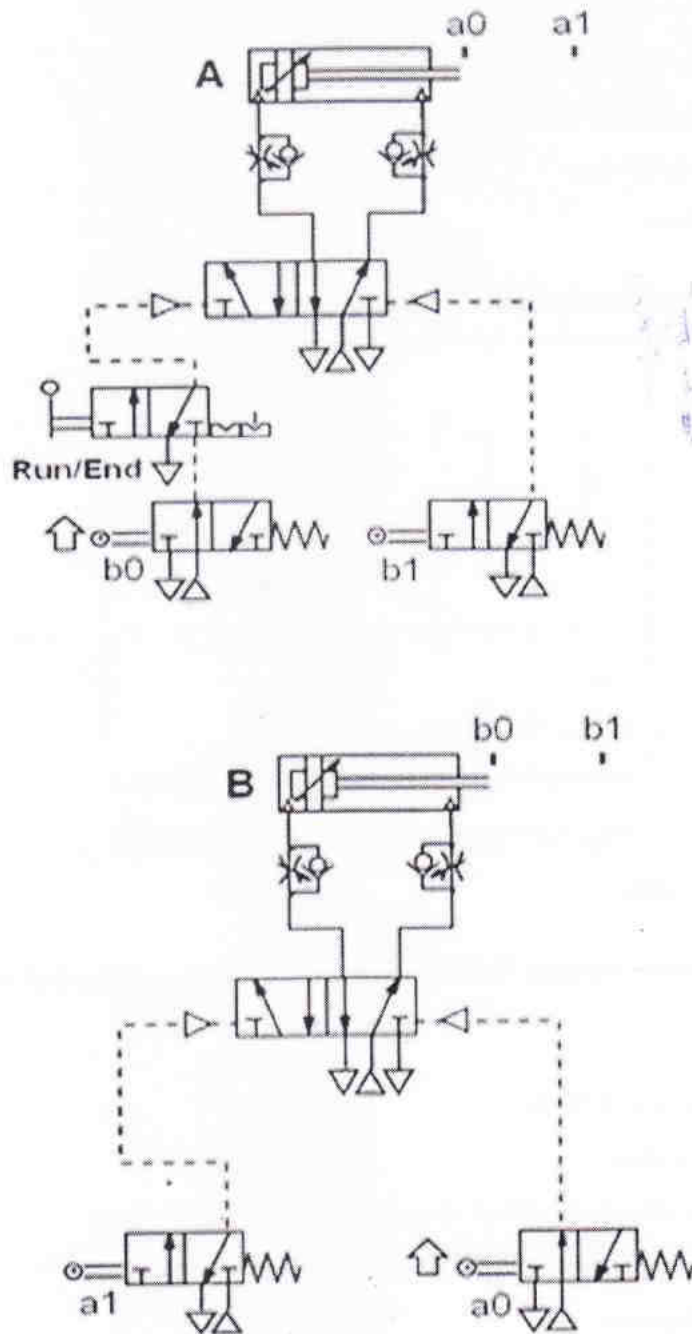

Fig. 7.2 Pneumatic Circuit diagram for drilling.

The two cylinders A and B are to perform a simple repeat pattern sequence as follows: A+ B+ A- B-  
 B-Apply the rule "The signal given by the completion of each movement will initiate the next movement"

*Hydraulic & Pneumatics (BE, 2015 Course)*  
*Laboratory Manual*

Components of the system:

1. 4/2 Pneumatic directional control valve
2. 3/2 Manually operated directional control valve
3. Double acting cylinder
4. Flow control valve

**Case Study2: Pneumatic Lift System:**

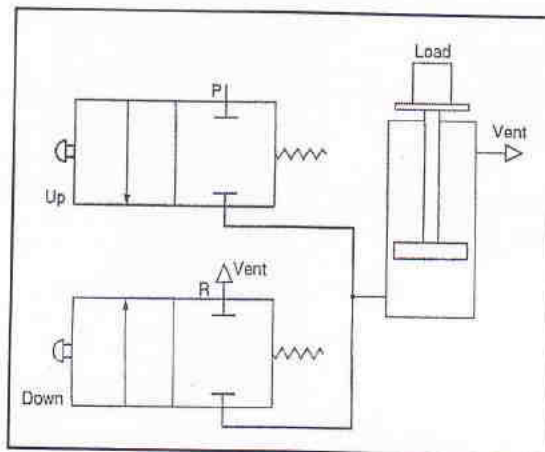

**Fig. 7.3 Typical Pneumatic Lift Circuit**

Components of the system:

The pneumatic lift system contains the following elements which are needed to carry out lifting work.

1. 2/2 Directional Control Valve
2. Single Acting Cylinder
3. Compressor (Not shown in circuit diagram)
4. Pressure Relief Valve (Not shown in circuit diagram)

Function of the Components:

1. 2/2 Directional Control Valve: It consists of a manually operated 2/2 directional control valve, which is normally at an open position. For lifting purposes, the valve is brought into a closed position and the lifting operation takes place. The pressure is adjusted according to the load to be lifted.

*Hydraulic & Pneumatics (BE, 2015 Course)*  
*Laboratory Manual*

2. Single Acting Cylinder: This contains arrangement for placing the load on the rod, which is connected directly to the piston.
3. Compressor: Its output is set according to the load requirement.
4. Pressure Relief Valve: Its function is to regulate the pressure in the system.

**Conclusion:**

To study the any pneumatic system we need to follow the sequence of 1) Listing Various Components, 2) Knowing their functions, 3) Draw the circuit diagram, 4) Check the circuit logic.

\* \* \* \* \*



Dr. D. Y. Patil Technical Campus

# **Dr. D. Y. Patil School of Engineering**

Dr. D. Y. Patil Knowledge City, Charholi (Bk), Lohegaon, Pune – 412 105

---

## **6) Dates For Journal Submission**



Dr. D. Y. Patil Group of Institutions' Technical Campus

# Dr. D. Y. PATIL SCHOOL OF ENGINEERING

Dr. D. Y. Patil Knowledge City, Charholi Bk., Via. Lohegaon, Pune - 412 105.

## Department of Mechanical Engineering

### Mechatronics Submission TE Mechanical D & F

S.N.	Title of the Experiment	Remark	D1		D2		D3		F1		F3	
			DOP	DOS	DOP	DOS	DOP	DOS	DOP	DOS	DOP	DOS
01	Measurement of Load using Load Cell		30.12	06.01	01.01	08.01	03.01	10.01	03.01	10.01	02.01	09.01
02	Demonstration of Bottle Filling Plant		06.01	13.01	08.01	15.01	10.01	17.01	10.01	17.01	09.01	16.01
03	Interfacing of Suitable Sensors with DAS	Observation Table from Manual	13.01	20.01	15.01	22.01	17.01	24.01	17.01	24.01	16.01	23.01
04	Ladder Diagram Simulation Using Arduino PLC Ladder Simulator	Screenshot of App	20.01	27.01	22.01	29.01	24.01	31.01	24.01	31.01	23.01	30.01
05	Real Time control of Temperature Using PID Control		27.01	03.01	29.01	05.02	31.01	07.02	31.01	07.02	30.01	06.02
06	PID Tuning using suitable software	PDF & Print of MATLAB Program and Output	03.01	10.02	05.02	12.02	07.02	14.02	07.02	14.02	06.02	13.02
07	Modeling and Analysis of Typical	PDF	10.02	17.02	12.02	19.02	14.02	21.02	14.02	21.02	20.02	





# Dr. D. Y. PATIL SCHOOL OF ENGINEERING

Dr. D. Y. Patil Knowledge City, Charholi Bk., Via. Lohegaon, Pune - 412 105.

Mechanical System	Details are given below	17.02	24.02	19.02	26.02	21.02	28.02	21.02	28.02	20.02	27.02
08	Case Study: Mechatronic System										

## Details of Experiment No. 08

### Case Study: Mechatronic System

For Case study Group of student has to study the given system from Mechatronics point of View.

You have to find out name of all Sensors used in the System with their detail technical configuration and logic used in the system.

You may use Book Named "Mechatronics in Action"/ Internet / Research Paper / Show Rooms. Put the name of Reference against your information collected.

Do not collect Generalised information but go for Specific information from Mechatronics, Sensors, actuators point of view.

Group No.	Name of the Students	Case Study
1	Aditya Verma	Hitachi 501L Frost Free Triple Door Refrigerator
	AGASHE TEJAS SUNIL	
	AMBHORKAR KAUSTUBH SURESH	
	AMRAO PRASHANT BHAUSAHEB	
2	AMRIT RAJ	Samsung 9KG Fully automatic Front Loading Washing Machine
	ANDHALE VAIBHAV BABAN	
	BANGAR TEJAS GAJABHAU	
3	BANKAR AKSHAY PRADEEP	LG 39L Convection Microwave Oven
	BARDHE ANIKET SUBHASHRAO	
	BARI PIYUSH HEMANT	





**Dr. D. Y. PATIL GROUP OF INSTITUTIONS' TECHNICAL CAMPUS**  
**Dr. D. Y. PATIL SCHOOL OF ENGINEERING**

Dr. D. Y. Patil Knowledge City, Charholi Bk., Via. Lohegaon, Pune - 412 105.

	BHALCHANDRA D SHIRKE BHANUSE SURAJ SANJAY BHARTI HARSHAL YASHWANT BHISHI OMKAR RAJU BONGANE SUBHASH K BORDE NITTIN UTTAM CHAKURE SOURABH SHIVAJI CHAUDHARI MAHESH AJIT CHAVAN OMKAR RAMAKANT DAGADE SAURABH LAXMAN DAKH AKSHAY LAKSHMANRAO DASARWAR PRANJAL GOPALRAO DAUND SOURABH ANAND DESAI ROHAN SANJAY DHANSHETTI SAINATH KASHINATH DHAYGUDE ABHIJEET M DUSANE HRISHIKESH DATATRAYA FUNDE PRAKASH BHAGWAN FUNDE SHUBHAM BHASKAR GADE SHAILESH PRASHANT GAIKWAD AADITYA MADHUKAR GAIKWAD NITESHKUMAR RAJENDRA GAIKWAD ROHIT UMESH GARSE NIKHIL PRASHANT GAVHANE AKSHAY SAMADHAN GAWADE ANIKETH BABASAHEB GAWALI MAHADEV SHASHIKANT GAWANDE HIMANSHU PRASHANT GHANOKAR PARAG SANJAY GHUBE GAURAV RAJENDRA GHUGE SAURABH SOPAN		Distance maintaining between two vehicles, Fuel injection system, Power steering, Air conditioner Used in Mahindra XUV300 Top End Model  Anti-lock braking, Air Bag System, Door System inTata Nexon Top End Model  Escalator used in Any Shopping Mall Near you  Vertical Machining Center VMC600  Xerox Versalink C505/X All in one color Laser Printer  Apple iPhone 11 Pro Max  Nikon D500 Camera  Hitachi 501L Frost Free Triple Door Refrigerator
11			





	HYALJI AMOL DAGAJI	
	JADHAV ABHISHEK KASHINATH	
	JHA BALRAM GUNANANAND	
	SHINDE TEJAS VIKAS	
12	SONAVANE DHIRAJ ANIL	LG 39L Convection Microwave Oven
	SONAVANE JAYESH SANDIP	
	SUMIT BHADORIYA	
	TANMAY VILAS UGHADE	
13	CHINCHOLE SAURABH DILIP	Anti-lock braking, Air Bag System, Door System in Tata Nexon Top End Model
	BHAVSAR SAGAR	
	MANOHAR MAHALE	
	BULANI HARSH KAMLESH	
14	JADHAV SHUBHAM ARUN	Vertical Machining Center VMC600
	PRASHIK SUDHIR INGALE	
	PAWAR KRISHNA DINESH	
	PAWAR RISHIKESH VIKRAMSING	
15	PAWAR TANAJI HANUMANT	Hitachi 501L Frost Free Triple Door Refrigerator
	PHALKE VIKRANT VIJAY	
	PHULSUNDAR SHUBHAM TUKARAM	
	POTE ANIKET SUNIL	
16	RANMALE SAMADHAN VINAYAK	Samsung 9KG Fully automatic Front Loading Washing Machine
	RAUT SHIV VILAS	
	SAHARE ARPIT SUDHAKAR	
	SALUNKE SIDDHARTH DNYANESHWAR	
17	SALUNKHE PRATIK RAMCHANDRA	LG 39L Convection Microwave Oven
	SALUNKHE SUBHASH SANJAY	
	SANGAVE MAHARUDRA HANUMANT	
	SANKHE TANAY SANJEEV	
18	SAPKAL SAURABH KISAN	Distance maintaining between two vehicles, Fuel injection system, Power steering, Air conditioner Used in Mahindra XUV300 Top End Model
	SARJE AKSHAYKUMAR SAHEBRAO	



# Dr. D. Y. PATIL SCHOOL OF ENGINEERING

Dr. D. Y. Patil Knowledge City, Charholi Bk, Via. Lohegaon, Pune - 412 105.

19	SARODE SHREYAS ANIL	Anti-lock braking, Air Bag System, Door System in Tata Nexon Top End Model
	SASTE SHUBHAM SAMBHAJI	
	SATTARSHETTY OMKAR RAJU	
	SAURABH MANIK RAUNDAL	
	WAGHULE SWAPNIL YASHWANT	
20	WALSE SANKET MACHHINDRA	Escalator used in Any Shopping Mall Near you
	YOJITA KIRTIRAJ RAJPUT	
	ZANZANE AKSHAY RATILAL	
	ZIRMIRE PARMESHWAR RAM	
	ZIRMIK KALYANI	
21	DESHMIK KALYANI	Vertical Machining Center VMC600
	ABHISHEK RAJENDRA SHINDE	
	SANKET PAWAR	
	OMKAR JOSHI	
	MANMOHAN NATH	
22	AJAY PANCHAL	Xerox Versalink C505/X All in one color Laser Printer
	RAJ KACHARE	
	SHASHANKDEV BERAULLY	
	NISHIT DAS	
	MANE SHASHIKANT UMAJI	
23	SUSHANT GAIKWAD	Apple iPhone 11 Pro Max
	RAUT KUNAL YOGESH	
	VENKATESH MUTHU PILLAI	
	ZINGADE SAURABH BHAGAWAT	
24		Nikon D500 Camera





Dr. D. Y. Patil Group of Institutions' Technical Campus

## DR. D. Y. PATIL SCHOOL OF ENGINEERING

Dr. D. Y. Patil Knowledge City, Charholi Bk., Via. Lohegaon, Pune - 412 105.

### Note:

1. Bring **New File**. Do not use old file. **Last date of Submission:**
2. Write appropriate **page numbers in Index** and on each **page** of file at **Right Hand Bottom Corner**.
3. Insert **Blank page** between each Tutorials & Write **Experiment No., Title of Experiment, Date of performance, Date of submission** on that blank page.
4. **Figure (with its title at bottom)** must be on **Left side** i.e. on **Blank page** with its description on **Right side**.  
**If there are any graphs, charts, prints, etc. please attach them before the Conclusion (Conclusion must be at the end of the tutorial).**
5. **Get your Journals checked, Sign on the submission sheet, Take HOD Signature, Principal Signature and bring your file at the time of Oral Examination.**

**Kunal S. Marathe**

Subject Teacher



<b>Dr. D. Y. PATIL SCHOOL OF ENGINEERING, Pune-412 105</b>		
<b>Department of Computer Engineering</b>		
Class: S.E. Div: B	<b>Subject: Data Structures and Algorithms (DSA)</b>	Sem. : IV
<b>List of Assignments (AY 2020-21)</b>		
Lectures per Week : 03		Subject In-charge : Prof. Nilesh Mali

Sr.No.	Assignment	Date
1	<p><b>Group A</b></p> <p>In second year computer engineering class, group A student's play cricket, group B students play badminton and group C students play football.</p> <p>Write a <b>Python</b> program using functions to compute following: -</p> <ol style="list-style-type: none"> <li>List of students who play both cricket and badminton</li> <li>List of students who play either cricket or badminton but not both</li> <li>Number of students who play neither cricket nor badminton</li> <li>Number of students who play cricket and football but not badminton.</li> </ol> <p>(Note- While realizing the group, duplicate entries should be avoided, Do not use SET built-in functions)</p>	25/03/2021
2	<p>Write a <b>Python</b> program that computes the net amount of a bank account based a transaction log from console input. The transaction log format is shown as following: D 100 W 200 (Withdrawal is not allowed if balance is going negative. Write functions for withdraw and deposit) D means deposit while W means withdrawal.</p> <p>Suppose the following input is supplied to the program: D 300, D 300 , W 200, D 100 Then, the output should be: 500</p>	31/03/2021
3	<p>Write a <b>Python</b> program to compute following operations on String:</p> <ol style="list-style-type: none"> <li>To display word with the longest length</li> <li>To determines the frequency of occurrence of particular character in the string</li> <li>To check whether given string is palindrome or not</li> <li>To display index of first appearance of the substring</li> <li>To count the occurrences of each word in a given string</li> </ol>	23/04/2021
4	<p>Write a <b>Python</b> program to compute following computation on matrix:</p> <ol style="list-style-type: none"> <li>Addition of two matrices</li> <li>Subtraction of two matrices</li> <li>Multiplication of two matrices</li> <li>Transpose of a matrix</li> </ol>	08/04/2021
5	<p><b>Group B</b></p> <p>Write a <b>Python</b> program to store names and mobile numbers of your friends in sorted order on names. Search your friend from list using binary search (recursive and non- recursive). Insert friend if not present in phonebook</p>	15/04/2021

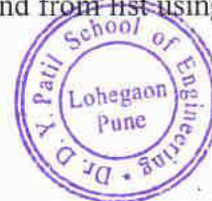

6	Write a <b>Python</b> program to store first year percentage of students in array. Write function for sorting array of floating point numbers in ascending order using a) Selection Sort b) Bubble sort and display top five scores	22/04/2021
7	<b>Group C</b> Second year Computer Engineering class, set A of students like Vanilla Ice-cream and set B of students like butterscotch ice-cream. Write C++ program to store two sets using linked list. compute and display- a) Set of students who like both vanilla and butterscotch b) Set of students who like either vanilla or butterscotch or not both Number of students who like neither vanilla nor butterscotch	30/04/2021
8	Write C++ program for storing binary number using doubly linked lists. Write functions- a) To compute 1's and 2's complement b) Add two binary numbers	06/05/2021
9	<b>Group D</b> In any language program mostly syntax error occurs due to unbalancing delimiter such as {}, [], (). Write C++ program using stack to check whether given expression is well parenthesized or not.	15/05/2021
10	In any language program mostly syntax error occurs due to unbalancing delimiter such as {}, [], (). Write C++ program using stack to check whether given expression is well parenthesized or not.	21/05/2021
11	Implement C++ program for expression conversion as infix to postfix and its evaluation using stack based on given conditions: 1. Operands and operator, both must be single character. 2. Input Postfix expression must be in a desired format. Only '+', '-', '*' and '/' operators are expected.	27/05/2021
12	<b>Group E</b> Queues are frequently used in computer programming, and a typical example is the creation of a job queue by an operating system. If the operating system does not use priorities, then the jobs are processed in the order they enter the system. Write C++ program for simulating job queue. Write functions to add job and delete job from queue.	08/06/2021
13	A double-ended queue (deque) is a linear list in which additions and deletions may be made at either end. Obtain a data representation mapping a deque into a one-dimensional array. Write C++ program to simulate deque with functions to add and delete elements from either end of the deque.	15/06/2021
14	Pizza parlor accepting maximum M orders. Orders are served in first come first served basis. Order once placed cannot be cancelled. Write C++ program to simulate the system using circular queue using array.	18/06/2021



Dr. D. Y. Patil Technical Campus

# **Dr. D. Y. Patil School of Engineering**

Dr. D. Y. Patil Knowledge City, Charholi (Bk), Lohegaon, Pune – 412 105

## 7) Examination Dates



# सावित्रीबाई फुले पुणे विद्यापीठ

(पूर्वीचे पुणे विद्यापीठ)



परिपत्रक क्र. ०४/२०२१

विषय : ऑक्टोबर/नोव्हेंबर, २०२० (नियोजन एप्रिल/मे, २०२१) परीक्षेच्या आयोजनाबाबत.  
संदर्भ : कोविड-१९ च्या पार्श्वभूमीवर विद्यापीठ अधिकार मंडळाने घेतलेले निर्णय.

कोविड-१९ च्या प्रादुर्भावाच्या पार्श्वभूमीवर विद्यापीठाच्या अधिकार मंडळांनी निश्चित केलेल्या मार्गदर्शक तत्वानुसार प्रथम वर्ष ते अंतिम वर्षातील विद्यार्थ्यांच्या ऑक्टोबर/नोव्हेंबर, २०२० या परीक्षांचे ऑनलाईन पध्दतीने नियोजन करण्यात येत आहे. याबाबतची मार्गदर्शक तत्वे व सूचना खालीलप्रमाणे आहेत.

१. प्रथम वर्ष ते अंतिम वर्षातील विद्यार्थ्यांच्या ऑक्टोबर/नोव्हेंबर, २०२० सर्व अभ्यासक्रमांच्या ऑनलाईन पध्दतीने परीक्षांचे नियोजन दिनांक १० एप्रिल, २०२१ पासून करण्यात आले आहे. या परीक्षा फक्त Online बहुपर्यायी प्रश्नांद्वारे (MCQ), एक तासाची परीक्षा अशा पध्दतीने घेण्यात येतील. Online पध्दतीने होणा-या बहुपर्यायी प्रश्न (MCQ) स्वरूपाच्या परीक्षा ह्या ५० गुणांच्या ६० मिनिटे (एक तास) कालावधीच्या राहतील. यासाठी ६० बहुपर्यायी प्रश्न (MCQ) दिले जातील त्यामधून ५० प्रश्नांची अचूक उत्तरे ग्राह्य धरण्यात येतील.
२. या परीक्षांकरिता बहुतांश अभ्यासक्रमांमधील (Programmes) पाठयक्रम (Syllabus) १०० टक्के पूर्ण झाला असल्याने त्या अभ्यासक्रमांच्या परीक्षा ह्या १०० टक्के पाठयक्रमांवर होतील. तसेच बी.ए., बी.कॉम. हे वार्षिक अभ्यासक्रम व बहिःस्थ यांच्याही परीक्षा १०० टक्के अभ्यासक्रमांवर होतील.
३. व्यावसायिक अभ्यासक्रमांचे शैक्षणिक वर्ष २०२०-२१ चे प्रथम सत्र दिनांक ६ फेब्रुवारी, २०२१ पासून सुरु झालेले आहे. जसे की, प्रथम सत्र वास्तुशास्त्र, औषधनिर्माणशास्त्र, अभियांत्रिकी, विधी, एम.एड, एम.पी.एड, बीएससी-बी.एड, बी.ए.-बी.एड या अभ्यासक्रमांच्या परीक्षा संबंधित अभ्यास मंडळांकडून प्राप्त सूचनेनुसार प्रथम घटकापासून (युनिट) सुरु होणा-या ७० टक्के अभ्यासक्रमांवर होतील.
४. प्रथम सत्राच्या परीक्षांसाठी फक्त लेखी परीक्षांचे (Theory Papers) गुण विद्यार्थ्यांना Students Profile System मार्फत उपलब्ध करून दिले जातील. नजिकच्या कालावधीमध्ये संबंधित विद्यार्थ्यांचे टप्प्याटप्प्याने निकाल जाहीर होतील. त्या निकालाच्या अनुषंगाने टप्प्याटप्प्याने मार्च/एप्रिल, २०२१ परीक्षेसाठी परीक्षा आवेदनपत्र उपलब्ध करून दिले जातील. तथापि, ऑक्टोबर/नोव्हेंबर, २०२० व मार्च/एप्रिल, २०२१ या परीक्षांची गुणपत्रके/श्रेयांक पध्दतीने एकत्रितरित्या नंतर कितरीत केली जातील.
५. खाली नमूद केलेल्या प्रथम वर्षाच्या अनुशोषित/नियमित (असल्यास) अभ्यासक्रमांच्या परीक्षा महाविद्यालय/परिसंस्था स्तरावर आयोजित करण्यात याव्यात.

कला B.A.2013

वाणिज्य B.B.A. (Computer Application) 2016  
B.B.M. (International Business) 2013  
B.B.A. (International Business) 2016  
B.B.A. (Revised 2013)  
B.Com. 2013

विधी B.A.LL.B.(Rev.2017)  
LL.B.(Rev.2017)



विज्ञान	B.Sc.(Biotech) 2013 B.Sc. (Animation) 2016 B.C.A. (Science) 2016 B.Sc. (Computer Science) 2013 B.Sc. HS (2017) B.Sc. Regular 2013
---------	--

अभियांत्रिकी M.E.(All Elective Subjects)

उपरोक्त परीक्षांचे आयोजन केंद्र व राज्य शासनाने शासनाने कोविड-१९ च्या पार्श्वभूमीवर निश्चित केलेल्या मार्गदर्शक सूचनांप्रमाणे आरोग्योची संपूर्ण काळजी घेऊन ऑनलाईन/ऑफलाईन (जसे शक्य होईल तसे) पध्दतीने बहुपर्यायी प्रश्न (MCQ) स्वरूपाच्या परीक्षा या ५० गुणांच्या ६० मिनिटे (एक तास) कालावधीच्या दिनांक १० एप्रिल, २०२१ पासून महाविद्यालय/परिसंस्था स्तरावर आवश्यक त्या उपलब्ध सुविधांचा वापर करून करण्यात यावे. यासाठी ६० बहुपर्यायी प्रश्न (MCQ) दिले जातील त्यामधून ५० प्रश्नांची अचूक उत्तरे ग्राह्य धरण्यात यावेत. या परीक्षांचे वेळापत्रक महाविद्यालय/परिसंस्था यांचे संकेतस्थळावर प्रसिध्द करण्यात यावे व याबाबतचा सविस्तर तपशील परीक्षा-समन्वय कक्षास सादर करण्यात यावा. तसेच यामधील अनुशेषित व नियमित परीक्षार्थींचे पेपर एकाच दिवशी येणार नाहीत याची संपूर्ण काळजी महाविद्यालय/परिसंस्था यांनी घ्यावी.

६. इन-सेमिस्टर, ऑनलाईन, संशानल परीक्षा (लेखी परीक्षेच्या विषयांसाठी व अभियांत्रिकी अभ्यासक्रमातील Fundamentals of Programming Languages या विषयांसाठी) महाविद्यालय/परिसंस्था स्तरावर उपलब्ध सुविधांचा वापर करून घेण्यात याव्यात. याबाबतचे वेळापत्रक महाविद्यालय/परिसंस्था स्तरावर निश्चित करून त्यानुसार विद्यार्थ्यांना अवगत करण्यात यावे. इंटरनल मार्कसू, वेब पोर्टल सुविधा वापरून विद्यार्थ्यांना या परीक्षांत मिळालेले गुण विद्यापीठाकडे दिनांक १० एप्रिल, २०२१ पर्यंत पाठविण्यात यावेत.
७. शैक्षणिक वर्ष २०२०-२१ मध्ये प्रथम ते द्वितीय सत्रासाठी एकत्रितरीत्या प्रात्यक्षिक, मौखिक, सेमिनार, मिनी प्रोजेक्ट्स, प्रोजेक्ट्स व डेझरटेशन परीक्षांचे आयोजन त्या त्या अभ्यासक्रमातील विद्यार्थ्यांच्या प्रथम सत्राच्या दिनांक १० एप्रिल, २०२१ पासून सुरु होणा-या विद्यापीठाच्या ऑक्टोबर/नोव्हेंबर, २०२० परीक्षांच्या शेवटच्या पेपरनंतर लगेचच ऑनलाईन/ऑफलाईन पध्दतीने करण्यात यावे. त्याकरिता वेगळे परिपत्रक निर्गमित केले जाणार नाही. या प्रात्यक्षिक व इतर उल्लेखित परीक्षांचे गुण त्वरीत इंटरनल मार्कस वेबपोर्टल सुविधा वापरून भरण्यात यावेत. कुठल्याही प्रात्यक्षिक, मौखिक, सेमिनार, मिनी प्रोजेक्ट्स, प्रोजेक्ट्स व डेझरटेशन परीक्षांकरिता परीक्षा विभागाकडून बहिःस्थ परीक्षकांच्या नेमणूका अथवा महाविद्यालयांकरिता वेगळे वेळापत्रक पाठविले जाणार नाही. संबंधित विद्यार्थ्यांच्या प्रथम सत्राच्या ऑनलाईन परीक्षा पूर्ण झाल्यावर लगेचच मा.प्राचार्य/संचालक यांनी महाविद्यालय स्तरावर परीक्षकांच्या नेमणूका करून परीक्षांचे आयोजन करावे. या परीक्षांचे गुण इंटरनल मार्कस वेबपोर्टल सुविधा वापरून भरण्यासाठी सुविधा उपलब्ध करून देण्यात येईल. फक्त एम.सी.ए.व एम.बी.ए. व तत्सम अभ्यासक्रमांच्या प्रात्यक्षिकांसाठी बहिःस्थ पर्यवेक्षक विद्यापीठाकडून नेमण्यात येतील.
८. ऑक्टोबर/नोव्हेंबर, २०२० च्या परीक्षांचे वेळापत्रक दिनांक २५ मार्च, २०२१ पर्यंत विद्यापीठाच्या [www.unipune.ac.in](http://www.unipune.ac.in) या संकेतस्थळावर प्रसिध्द केले जाईल. या परीक्षा निर्धारित वेळेत पूर्ण होणे अनिवार्य असल्यामुळे विद्यापीठ अधिकार मंडळाने घेतलेल्या निर्णयानुसार विशेष बाब म्हणून बहुपर्यायी परीक्षांचे आयोजन सर्व रविवाराच्या दिवशीही करण्यात आलेले आहे याची कृपया नोंद घ्यावी.
९. प्रथम वर्ष ते अंतिम वर्षातील विद्यार्थ्यांच्या ऑनलाईन परीक्षांच्या बाबतीत आवश्यक ती सर्व माहिती विद्यार्थ्यांना एसएमएस व ई-मेल्वारे अवगत करण्यात येईल. मात्र यासाठी विद्यार्थ्यांचा नोंदणीकृत ई-मेल आयडी व मोबाईल क्रमांक कार्यान्वित असणे आवश्यक आहे.
१०. Online परीक्षेत काही तांत्रिक कारणाने खंड पडल्यास तेवढाच कालावधी संबंधित विद्यार्थ्यांला संगणकीय प्रणालीतून वाढवून दिला जाईल. यापूर्वी सोडविलेली उत्तरे ही सेव्ह होऊन खंड पडल्यास तेथून परीक्षा पुन्हा सुरु होईल.
११. Online परीक्षेची संपूर्ण माहिती होण्यासाठी सर्वसाधारण प्रश्नांवर आधारित सराव परीक्षांचे आयोजन (Mock Test/Practice Test) मुख्य परीक्षेपूर्वी दिनांक ७ एप्रिल, २०२१ पासून करण्यात येईल व तसे सर्व संबंधितांला अवगत करण्यात येईल.



१२. दिव्यांग विद्यार्थ्यांना शासन निर्णयप्रमाणे सोयी व सवलती देव राहतील. तसेच या विद्यार्थ्यांना परीक्षेसाठी २० मिनिटे अधिकचा वेळ देव राहिल.
१३. Online पध्दतीने होणा-या बहुपर्यायी प्रश्न (MCQ)परीक्षांसाठी छायांकित प्रत व पुनर्मूल्यांकनाची सुविधा उपलब्ध राहणार नाही.
१४. ज्या महाविद्यालयांकडून ज्या विद्यार्थ्यांचे इन सेमिस्टर, ऑनलाईन व सेशनल परीक्षांचे अंतर्गत गुण दिनांक १० एप्रिल, २०२१ पर्यंत विद्यापीठास प्राप्त होतील त्याच विद्यार्थ्यांचे निकाल फक्त ऑनलाईन पध्दतीने जाहीर करण्यात येतील व गुणपत्रके मार्च/एप्रिल, २०२१ च्या परीक्षांचे निकालाबरोबरच एकत्रित वितरीत करण्यात येतील याची नोंद घ्यावी.
१५. विद्यापीठ अधिकार मंडळाने मान्य केलेल्या परीक्षा आराखडयानुसार विद्यार्थ्यांच्या संबंधित परीक्षेसाठी गुणांचे रूपांतरण केले जाईल. उदा. अभियांत्रिकी अभ्यासक्रमासाठी परीक्षा आराखडयानुसार ७० गुणांची परीक्षा आहे. या अभ्यासक्रमांचे विद्यार्थी ऑक्टोबर/नोव्हेंबर, २०२० ची ऑनलाईन पध्दतीने ५० गुणांची बहुपर्यायी प्रश्नांवर आधारित परीक्षा देतील. या परीक्षेत ५० पैकी विद्यार्थ्यांस मिळालेले गुण गणितीय सूत्र वापरून ७० गुणांपैकी मिळालेल्या गुणांत रूपांतरित केले जातील.
१६. परिपत्रक क्र.१२५ अंतर्गत येणा-या अभ्यासक्रमांच्या परीक्षेचे नियोजन महाविद्यालय स्तरावर विद्यापीठाच्या परीक्षांच्या नियोजनाच्या धर्तीवर करण्यात यावे. स्वायत्त महाविद्यालय/संस्थांनी सर्व निवमांचे अनुपालन करून परीक्षा घेण्यात याव्यात.
- उपरोक्त परीक्षांचे आयोजन केंद्र व राज्य शासनाने शासनाने कोविड-१९ च्या पार्श्वभूमीवर निश्चित केलेल्या मार्गदर्शक सूचनांप्रमाणे आरोग्याची संपूर्ण काळजी घेऊन ऑनलाईन/ऑफलाईन (जसे शक्य होईल तसे) पध्दतीने बहुपर्यायी प्रश्न (MCQ) स्वरूपाच्या परीक्षा या ५० गुणांच्या ६० मिनिटे (एक तास) कालावधीच्या दिनांक १० एप्रिल, २०२१ पासून महाविद्यालय/परिसंस्था स्तरावर आवश्यक त्या उपलब्ध सुविधांचा वापर करून करण्यात यावे. यासाठी ६० बहुपर्यायी प्रश्न (MCQ) दिले जातील त्यामधून ५० प्रश्नांची अचूक उत्तरे ग्राह्य धरण्यात यावेत. या परीक्षांचे वेळापत्रक महाविद्यालय/परिसंस्था यांचे संकेतस्थळावर प्रसिध्द करण्यात यावे व याबाबतचा सर्विस्तर तपशील परीक्षा-समन्वय कक्षास सादर करण्यात यावा. तसेच यामधील अनुशोधित व नियमित परीक्षार्थींचे पेपर एकाच दिवशी येणार नाहीत याची संपूर्ण काळजी महाविद्यालय/परिसंस्था यांनी घ्यावी.
१७. सदर परीक्षांच्या आयोजनापूर्वी व परीक्षेदरम्यान येणा-या अडचणी व शंकांचे निराकरण करण्यासाठी विद्यार्थ्यांनी [sps.unipune.ac.in](http://sps.unipune.ac.in) मध्ये लॉगिन करून आपल्या तक्रारी नोंदवाव्यात, तसेच विद्यार्थ्यांनी त्यांच्या संबंधित महाविद्यालय/परिसंस्थेमध्ये संपर्क साधावा.

मा.प्राचार्य/संचालक/महाविद्यालयीन परीक्षा अधिकारी यांना विनंती करण्यात येते की, वरील मार्गदर्शक तत्वे व सूचनांचे अवलोकन करून याबाबत आपल्या महाविद्यालयातील सर्व शिक्षक, शिक्षकेतर सेवक व विद्यार्थी यांना आपल्या स्तरावरून सूचित करावे व त्यांच्या शंकांचे निरसन करून विद्यापीठास सहकार्य करावे.

कळावे,

संदर्भ : परीक्षा-समन्वय/५३(अ)  
दिनांक : १६ मार्च, २०२१

  
(महेश काकडे)

संचालक  
परीक्षा व मूल्यमापन मंडळ

प्रति,

१. मा. प्राचार्य/संचालक  
सर्व संलग्नित महाविद्यालये/मान्यताप्राप्त परिसंस्था,  
पुणे, अहमदनगर, नाशिक जिल्हा



## सावित्रीबाई फुले पुणे विद्यापीठ (पूर्वीचे पुणे विद्यापीठ)



परिपत्रक क्र. १२६/२०२०

विषय :- शैक्षणिक वर्ष २०२०-२१ च्या प्रथम सत्रासाठी (ऑक्टोबर/नोव्हेंबर २०२०)  
आयोजित करावयाच्या प्रात्यक्षिक/मौखिक/सेमिनार/प्रोजेक्ट/सेशनल परीक्षाबाबत..

कोविड-१९ करोना साथीच्या प्रादुर्भावामुळे विद्यापीठ संलग्नित सर्व महाविद्यालयातील शैक्षणिक उपक्रम प्रत्यक्षरित्या सुरु होऊ शकलेली नाहीत. त्यामुळे महाविद्यालयातील विद्यार्थी प्रयोगशाळा व इतर तांत्रिक साधनसामुग्रीचा उपयोग करून प्रात्यक्षिके करू शकलेली नाहीत. अशा परिस्थितीत महाविद्यालये नियमित सुरु झाल्यानंतरच ही प्रात्यक्षिके घेण्यात येणार आहेत. या सर्व अडचणीची चर्चा सावित्रीबाई फुले पुणे विद्यापीठाच्या विविध अधिकार मंडळाच्या सभेत करण्यात आली. यासंदर्भात विद्यापीठ अधिकारमंडळाने घेतलेल्या निर्णयानुसार कळविण्यात येते की, सर्व संलग्नित महाविद्यालयातील नियमित (Fresh) विद्यार्थ्यांच्या शैक्षणिक वर्ष २०२०-२१मधील प्रथम व द्वितीय सत्राच्या प्रात्यक्षिक/मौखिक/सेमिनार/प्रोजेक्ट/सेशनल इत्यादी महाविद्यालय स्तरावरील घेण्यात येणा-या सर्व (लेखी/तोंडी) परीक्षा एकत्रितरीत्या शैक्षणिक वर्ष २०२०-२१ च्या द्वितीय सत्राच्या (मार्च/एप्रिल २०२१) परीक्षा समवेत सत्रनिहाय स्वतंत्रपणे घेण्यात याव्यात.

तसेच या नियमित विद्यार्थ्यांचे परीक्षा आवेदन पत्र भरतांना Online Exam Form भरण्याच्या प्रक्रियेमध्ये कोणताही बदल न करता लेखी परीक्षांबरोबर, प्रात्यक्षिक/मौखिक/सेमिनार/प्रोजेक्ट/सेशनल व इतर अभ्यासक्रमामध्ये नमुद परीक्षांची माहिती प्रचलित पध्दतीनुसार भरण्यात यावी. तथापि तांत्रिक अडचणी येऊ नये म्हणून या नियमित (Fresh) विद्यार्थ्यांचे प्रथम सत्रातील विद्यापीठ परीक्षांचे निकाल फक्त ऑनलाईन पध्दतीने जाहीर करण्यात येतील तसेच प्रथम व द्वितीय सत्राच्या मूळ गुणपत्रिका एकत्रितरीत्या द्वितीय सत्राच्या गुणपत्रकांसमवेत स्वतंत्रपणे एकत्र महाविद्यालयात पाठविण्यात येतील.

पुढे असेही कळविण्यात येते की, अनुशेषित (Backlog) विद्यार्थ्यांच्या प्रात्यक्षिक/मौखिक/सेमिनार/प्रोजेक्ट/सेशनल परीक्षा मात्र नेहमीप्रमाणे आयोजित करण्यात येऊन त्यांचे प्रथम सत्राचे निकाल लेखी परीक्षेच्या आयोजनानंतर जाहीर करण्यात येईल.

मा. प्राचार्य/संचालक, सर्व संलग्नित महाविद्यालये/मान्यताप्राप्त संस्था यांना विनंती करण्यात येते की, सदर परिपत्रकाचा आशय आपल्या महाविद्यालयातील विद्यार्थी, शिक्षक, शिक्षकेतर सेवक व इतर सर्व संबंधितांना अवगत करण्यात यावा व सदर परिपत्रकानुसार पुढील आवश्यक कार्यवाही करण्यात यावी.

(महेश काकडे)

संचालक

परीक्षा व मूल्यमापन मंडळ

संदर्भ : परीक्षा-समन्वय/४४३

दिनांक : २२/१२/२०२०

प्रत माहितीसाठी व योग्य त्या कार्यवाहीसाठी:-

मा. प्राचार्य/संचालक, सर्व संलग्नित महाविद्यालये व मान्यताप्राप्त संस्था.



FF

SPPU OE Backlog Exam Time Table of F.E. (2015) course

Sr. No.	Course and Subject	No. of Students	F.E. Course	Seat Numbers	Date of Online examination	Time of examination	Mode of Conduction	Duration of exam	No of MCQs	Max Marks	Number of Units	Internal Examiner	Email ID of Examiner	Contact Number of Examiner
1	107002 ENGINEERING PHYSICS[OE][TH] 1	1	2015	F150880025		will be communicated by the concerned Internal Examiner	Google Form	60 min	60	50	1,2,3,4	Dr. Sachin Suryawanshi	Sachin.suryawanshi@spu.ac.in	9763363966
2	107008 ENGINEERING MATHEMATICS-II [OE][TH] 9	9	2015	F150880015, F150880006, F150880011, F150880012, F150880015, F150880016, F150880022, F150880024, F150880025, F150880026	will be communicated by the concerned Internal Examiner	will be communicated by the concerned Internal Examiner	Google Form	60 min	60	50	1,2,3,4	Dr. Rahul Kothode	rahul.kothode@spu.ac.in	7755907798
3	101011 ENGINEERING Mechanical[OE][TH] 6	6	2015	F150880025, F150880012, F150880017, F150880024, F150880025 + add one			Google Form	60 min	60	50	1,2,3,4	Mr. Prasad Gayak	Prasad.gayak@spu.ac.in	8623995483

Prof. V.D. Tringale  
FE Exam coordinator

Dr. S.M. Khairnar  
HOD FE Dept





Dr. D. Y. Patil Technical Campus  
**Dr. D. Y. Patil School of Engineering**  
Dr. D. Y. Patil Knowledge City, Charholi (Bk), Lohgaon, Pune – 412 105

**DEPARTMENT OF CIVIL ENGINEERING**

**Date: 24/03/2021**

**OFFICE ORDER**

**BE (CIVIL ENGINEERING) (2012& 2015) In-semester Exam Oct/Nov 2020 (Semester I)**

I am pleased to assign the following staff as Sr. Supervisor and Jr. Supervisor for BE In-semester Exam Oct/Nov 2020, Academic Year 2020-21. (SEMESTER -I)

A] Sr. Supervisor: Prof. Swapnil Bijwe/Prof.Uday Kakde

B] Jr. Supervisor

Sr. No.	Day & Date	Time	SUBJECT	Invigilator/ Faculty
1	Friday, 26/03/2021	1:00 PM To 1:40 PM	Environmental Engineering-II (401001)	Prof. Rajesh C. Katdare
2	Saturday, 27/03/2021	1:00 PM To 1:40 PM	Transportation Engineering (401002)	Prof. Pragya Sharma
3	Sunday, 28/03/2021	1:00 PM To 1:40 PM	Structural Design and Drawing- III (401003)	Prof. Ahinsak Taksande
4	Tuesday, 30/03/2021	1:00 PM To 1:40 PM	Elective-I Advanced Concrete Technology(401004)	Prof. Ahinsak Taksande
		1:00 PM To 1:40 PM	Elective-I Architectural and Town Planning(401004)	Prof. Uzma A Shaikh
5	Wednesday, 31/03/2021	1:00 PM To 1:40 PM	Elective-II TQM & MIS in Civil Engineering (401005)	Prof. Lt. Col. Sanjay Karodpati

Dr. Ashok Kasnale  
Principal

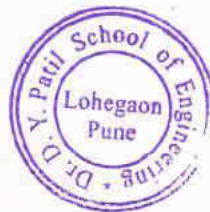



Dr. D. Y. Patil Technical Campus  
**Dr. D. Y. Patil School of Engineering**  
Dr. D. Y. Patil Knowledge City, Charholi (Bk), Lohgaon, Pune – 412 105

**DEPARTMENT OF CIVIL ENGINEERING**

**Date: 24/03/2021**

**OFFICE ORDER**

**SE (CIVIL ENGINEERING) (2015& 2019) In-semester Exam Oct/Nov 2020 (Semester I)**

I am pleased to assign the following staff as Sr. Supervisor and Jr. Supervisor for SE In-semester Exam Oct/Nov 2020, Academic Year 2020-21. (SEMESTER -I)

A] Sr. Supervisor: Prof. Swapnil Bijwe/Prof.Uday Kakde

B] Jr. Supervisor

Sr. No.	Day &Date	Time	SUBJECT	Invigilator/ Faculty
1	<b>Friday,</b> 26/03/2021	12:00 PM TO 12.40 PM	Building Technology and Architectural Planning (201001)	Prof. Aakanksha A. Ingle
2	<b>Saturday,</b> 27/03/2021	12:00 PM TO 12.40 PM	Mechanics of Structures (201002)	Prof. Aniket Vilas Nemade
3	<b>Sunday,</b> 28/03/2021	12:00 PM TO 12.40 PM	Fluid Mechanics (201003)	Prof. Uzma A Shaikh
4	<b>Tuesday,</b> 30/03/2021	12:00 PM TO 12.40 PM	Engineering Mathematics-III (207001)	Dr. Rahul Katkade
5	<b>Wednesday,</b> 31/03/2021	12:00 PM TO 12.40 PM	Engineering Geology (207009)	Prof. Pragya Sharma

  
Dr. Ashok Kasnale  
Principal





Dr. D. Y. Patil Technical Campus  
**Dr. D. Y. Patil School of Engineering**  
Dr. D. Y. Patil Knowledge City, Charholi (Bk), Lohgaon, Pune - 412 105

**DEPARTMENT OF CIVIL ENGINEERING**

**Date: 24/03/2021**

**OFFICE ORDER**

**TE (CIVIL ENGINEERING) (2012& 2015) In-semester Exam Oct/Nov 2020 (Semester I)**

I am pleased to assign the following staff as Sr. Supervisor and Jr. Supervisor for TE In-semester Exam Oct/Nov 2020, Academic Year 2020-21. (SEMESTER -I)

A] Sr. Supervisor: Prof. Swapnil Bijwe/Prof.Uday Kakde

B] Jr. Supervisor

Sr. No.	Day & Date	Time	SUBJECT	Invigilator/ Faculty
1	<b>Friday,</b> 26/03/2021	11:00 AM TO 11.40 AM	Hydrology and Water Resource Engineering (301001)	Prof. Rajesh C. Katdare
2	<b>Saturday,</b> 27/03/2021	11:00 AM TO 11.40 AM	Infrastructure Engineering and Construction Techniques (301002)	Prof. Aakanksha A. Ingle
3	<b>Sunday,</b> 28/03/2021	11:00 AM TO 11.40 AM	Structural Design-I (301003)	Prof.Jitrendra Dalvi
4	<b>Tuesday,</b> 30/03/2021	11:00 AM TO 11.40 AM	Structural Analysis-II (301004)	Prof. Uday A. Kakde
5	<b>Wednesday,</b> 31/03/2021	11:00 AM.TO 11.40 AM	Fluid Mechanics-II (301005)	Prof. Swapnil P. Bijwe

  
Dr. Ashok Kasnale  
Principal







Dr. D. Y. Patil Technical Campus

# Dr. D. Y. Patil School of Engineering

Dr. D. Y. Patil Knowledge City, Charholi (Bk), Lohgaon, Pune - 412 105

Website: [www.dypic.in](http://www.dypic.in)

Contact No.: 020-30619457

22.03.2021

## In Semester Examination Notice Oct-Nov 2020 conducted in March 2021

**Subject:** Conduction of INSEM (Online Mode) examination (October/November 2020) conducted in March 2021 for the academic year 2020-2021

**Reference:** SPPU Circular No. 4 / 2021 dated March 16, 2021

As per the guidelines received by SPPU, the INSEM examination for the students (FE to BE, Regular and Repeater) will be conducted from 26<sup>th</sup> March, 2021 to 31<sup>st</sup> March, 2021 at the Institute level using LMS Platform in accordance with the guidelines laid down by the Central, State Government and affiliating university on the background of COVID-19.

Following are the instructions and guidelines for the conduction of In Semester Examination:

1. Candidates are instructed to be ready for exam before 10 minutes with ensuring the availability of internet facility, required data pack and sufficient charging of the electronic gadgets before start of examination.
2. The INSEM exams will be of 30 Marks, 40 minutes duration and questions will be MCQ only. Out of 40 MCQ only 30, correctly answered questions will be considered as the final score of the students and same score will be communicated to the University for Declaration of result.
3. If any student having issues related to LMS login credentials, then those students must approach Department LMS coordinator on or before 24<sup>th</sup> March, 2021 to resolve the issue well in advance.
4. FE, SE INSEM Exam will be based on first TWO units and for TE, BE INSEM Exam will be based on first THREE units (As per the structure)
5. Candidates are requested to keep checking their Social Media accounts for notification and modification in notification of examination schedule

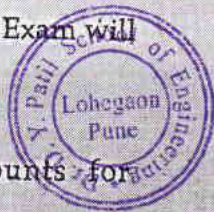

6. No request for any special concession such as a change in time or any day fixed for the University In semester Examination on any ground shall be granted.
7. Candidates are requested to note the Day, Date and Time of every Paper on every day.
8. The student who failed to raise the issues/queries encountered before or during the examination within stipulated time will not be considered later. The student will be solely responsible for the academic loss, if any.
9. In case of any technical difficulties/ network issues, the concerned student must immediately contact to Department LMS Coordinator/ HOD/ Mentor/ Class Teacher of their class to resolve the issue.
10. A candidate can appear only once for examination.
11. Any malfunctioning found during the conduct of examination will be strictly punished
12. The In semester Online examination will be conducted in the following order.

FE	:	10.00 am to 10.40 am
SE	:	12.00 noon to 12.40 pm
TE	:	11.00 am to 11.40 am
BE	:	01.00 pm to 01.40 pm

NOTE: The End Semester Examination will be conducted by the SPPU as per the above-cited reference attached herewith for information. All the students are advised to adhere the guidelines / instructions mentioned in the said circular.

For ME

The INSEMESTER Assessment will be carried out as per usual procedure mentioned in ME Rule book and the ENDSEM exam will be conducted by the university as per Time Table declared by SPPU.

  
Prof. Prashant Karajagi  
College Exam Officer



  
22/10/2024  
Dr. Ashok Kasnale  
Principal



Dr. D. Y. Patil Technical Campus

## Dr. D. Y. Patil School of Engineering

Dr. D. Y. Patil Knowledge City, Charholi (Bk), Lohgaon, Pune - 412 105

Website: [www.dypic.in](http://www.dypic.in)

Contact No.:020-30619457

24.05.2021

### FE, SE, TE, BE In Semester Examination (SEM-II) Notice April May 2021 conducted in May June 2021

**Subject:** Conduction of INSEM (Online Mode) examination (April / May 2021) Sem-II conducted in May- June 2021 for the academic year 2020-2021

As per the guidelines received by SPPU, the INSEM examination for the students of FE (14.06.2021 to 18.06.2021) SE, TE & BE (29.05.2021 to 06.06.2021) will be conducted at the Institute level using LMS Platform in accordance with the guidelines laid down by the Central, State Government and affiliating university on the background of COVID-19.

Following are the instructions and guidelines for the conduction of In Semester Examination:

1. Candidates are instructed to be ready for exam before 10 minutes with ensuring the availability of internet facility, required data pack and sufficient charging of the electronic gadgets before start of examination.
2. The INSEM exams will be of 30 Marks, 40 minutes duration and questions will be MCQ only. Out of 40 MCQ only 30, correctly answered questions will be considered as the final score of the students and same score will be communicated to the University for Declaration of result.
3. If any student having issues related to LMS login credentials, then those students must approach Department LMS coordinator on or before 25<sup>th</sup> May, 2021 to resolve the issue well in advance.
4. FE, SE INSEM Exam will be based on first TWO units and for TE, BE INSEM Exam will be based on first THREE units (As per the structure)
5. Candidates are requested to keep checking their Social Media accounts for notification and modification in notification of examination schedule
6. No request for any special concession such as a change in time or any day fixed for the University In semester Examination on any ground shall be granted, except Serious



situation of COVID 19 with valid proof.

7. Candidates are requested to note the Day, Date and Time of every Paper on every day.
8. The student who failed to raise the issues/queries encountered before or during the examination within stipulated time will not be considered later. The student will be solely responsible for the academic loss, if any.
9. In case of any technical difficulties/ network issues, the concerned student must immediately contact to Department LMS Coordinator/ HOD/ Mentor/ Class Teacher of their class to resolve the issue.
10. A candidate can appear only once for examination.
11. Any malfunctioning found during the conduct of examination will be strictly punished
12. The In semester Online examination will be conducted in the following order.

FE	:	Time Slot 10:00 AM - 12:30 PM (40 Minutes)
SE	:	Time Slot 10:00 AM - 12:30 PM (40 Minutes)
TE	:	Time Slot 12:30 PM - 03:00 PM (40 Minutes)
BE	:	Time Slot 03:00 PM - 05:30 PM (40 Minutes)

**For ME**

The INSEMESTER Assessment will be carried out as per usual procedure mentioned in ME Rule book and the ENDSEM exam will be conducted by the university as per Time Table declared by SPPU.

  
**Prof. Prashant Karajagi**  
College Exam Officer



  
**Dr. Ashok Kasnale**  
Principal





"Empowerment through Quality Technical Education"

## Dr. D. Y. Patil School of Engineering

Dr. D. Y. Patil Knowledge City, Charholi (Bk), Lohgaon, Pune - 412 105

Website: [www.dypsoe.in](http://www.dypsoe.in)

12.10.2021

### TE BE In Semester Examination Notice (Semester I) August 2021 conducted in October 2021

**Subject:** Conduction of INSEM (Online Mode) examination (August 2021) conducted in October 2021 for the academic year 2021-2022

**Reference:** SPPU Circular No. पमुमं/२०२१/०३७, Dated 09/10/2021

As per the guidelines received by SPPU, the INSEM examination for the students (TE & BE), Regular and Repeater) will be conducted from 18<sup>th</sup> October, 2021 to 24<sup>th</sup> October, 2021 at the Institute level using LMS Platform in accordance with the guidelines laid down by the Central, State Government and affiliating university on the background of COVID-19.

Following are the instructions and guidelines for the conduction of In Semester Examination:

1. Candidates are instructed to be ready for exam before 10 minutes with ensuring the availability of internet facility, required data pack and sufficient charging of the electronic gadgets before start of examination.
2. The INSEM exams will be of 30 Marks, 40 minutes duration and questions will be MCQ only. Out of 40 MCQ only 30, correctly answered questions will be considered as the final score of the students and same score will be communicated to the University for Declaration of result. For 2015 Pattern: First 03 Units, For 2019 Pattern: First 02 Units.
3. If any student having issues related to LMS login credentials, then those students must approach Department LMS coordinator on or before 14<sup>th</sup> October, 2021 to resolve the issue well in advance.
4. Candidates are requested to keep checking their Social Media accounts for notification and modification in notification of examination schedule
5. No request for any special concession such as a change in time or any day fixed for the University In semester Examination on any ground shall be granted.

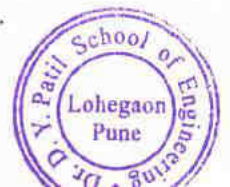

6. Candidates are requested to note the Day, Date and Time of every Paper on every day.
7. The student who failed to raise the issues/queries encountered before or during the examination within stipulated time will not be considered later. The student will be solely responsible for the academic loss, if any.
8. In case of any technical difficulties/ network issues, the concerned student must immediately contact to Department LMS Coordinator/ HOD/ Mentor/ Class Teacher of their class to resolve the issue.
9. A candidate can appear only once for examination.
10. Any malfunctioning found during the conduct of examination will be strictly punished
11. The Timetable for the Insemester Examination is as follows.

PKS.  
12/10/2021

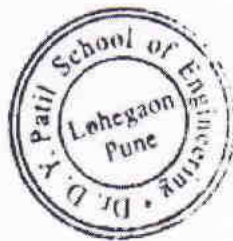

Dr. Farook Sayyad

Prof. Prashant Karajagi  
College Exam Officer

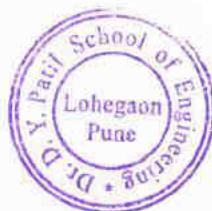

Dr. Farook Sayyad  
Principal



# DR. D. Y. PATIL SCHOOL OF ENGINEERING,

Charoli (Bk.), Via Lohgaon, Pune.

SAVITRIBAI PHULE PUNE UNIVERSITY

(Formerly University of Pune)



Programme of T.E. [All Branches ( In Semester- I ) (Online) 2015 & 2019 Course]  
Examinations,  
August 2021 conducted in October 2021

## T.E.(CIVIL)

### SEMESTER-I

Time – 12:00 to 01.30 p.m.

Day & Date	SUBJECT (2012& 2015 Course)	SUBJECT (2019 Course)
Monday 18.10.2021	Hydrology and Water Resource Engineering (301001)	Hydrology and Water Resources Engineering (301001)
Wednesday 20.10.2021	Infrastructure Engineering and Construction Techniques (301002)	Water Supply Engineering (301002)
Thursday 21.10.2021	Structural Design I (301003)	Design of Steel Structures (301003)
Friday 22.10.2021	Structural Analysis II (301004)	Engineering Economics and Financial Management (301004)
Saturday 23.10.2021	Fluid Mechanics II (301005)	Elective I (301005)
Sunday 24.10.2021	NA	Honors (If Any)

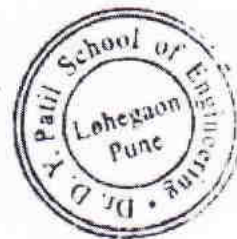

# T.E.(COMPUTER)

SEMESTER-I

Time – 12:00 to 01.30 p.m.

Day & Date	SUBJECT (2012& 2015 Course)	SUBJECT (2019 Course)
Monday 18.10.2021	Theory of Computation (310241)	Elective I (314245)
Wednesday 20.10.2021	Database Management Systems (310242)	Computer Networks & Security (310244)
Thursday 21.10.2021	Software Engineering & Project Management (310243)	Database Management Systems (310241)
Friday 22.10.2021	Information Systems and Engineering Economics (310244)	Theory of Computation (310242)
Saturday 23.10.2021	Computer Networks (310245)	System Programming and Operating System (310243)
Sunday 24.10.2021	NA	Honors (If Any)





# T.E. (ELECTRONICS & TELECOMMUNICATIONS)

SEMESTER-I

Time – 12:00 to 01.30 p.m.

Day & Date	SUBJECT (2012& 2015 Course)	SUBJECT (2019 Course)
Monday 18.10.2021	Digital Communication (304181)	Digital Communication (304181)
Wednesday 20.10.2021	Digital Signal Processing (304182)	Electromagnetic Field Theory (304182)
Thursday 21.10.2021	Electromagnetics (304183)	Database Management (304183)
Friday 22.10.2021	Microcontrollers (304184)	Microcontrollers (304184)
Saturday 23.10.2021	Mechatronics (304185)	Digital Signal Processing (304185)
Sunday 24.10.2021	NA	Robotics (Honor course )

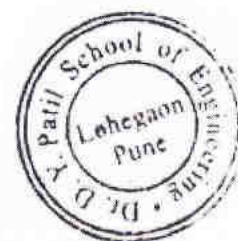
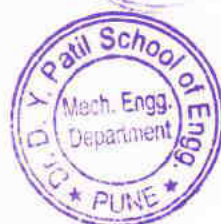

## T.E. (MECHANICAL)

### SEMESTER-I

Time – 01:30 to 03.00 p.m.

Day & Date	SUBJECT (2012& 2015 Course)	SUBJECT (2019 Course)
Monday 18.10.2021	Design of Machine Elements-I (302041)	Numerical & Statistical Methods (302041)
Wednesday 20.10.2021	Heat Transfer (302042)	Heat & Mass Transfer (302042)
Thursday 21.10.2021	Theory of Machines-II (302043)	Design of Machine Elements (302043)
Friday 22.10.2021	Turbo Machines (302044)	Mechatronics (302044)
Saturday 23.10.2021	Metrology and Quality Control (302045)	Elective I (302045)
Sunday 24.10.2021	NA	Robotics (Honor course )

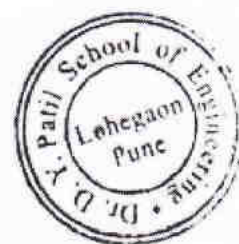

# DR. D. Y. PATIL SCHOOL OF ENGINEERING,

Charoli (Bk.), Via Lohgaon, Pune.

SAVITRIBAI PHULE PUNE UNIVERSITY

(Formerly University of Pune)



Programme of B.E. [All Branches ( In Semester- I ) (Online) 2012 & 2015 Course]  
Examinations,

August 2021 conducted in October 2021

**B.E.(CIVIL)**

**SEMESTER-I**

**Time – 02.30 to 04.00 p.m.**

Day & Date	SUBJECT (2012 Course)	SUBJECT (2015 Course)
Monday 18.10.2021	Environmental Engineering – II (401001)	Environmental Engineering – II (401001)
Wednesday 20.10.2021	Transportation Engineering (401002)	Transportation Engineering (401002)
Thursday 21.10.2021	Structural Design and Drawing –III (401003)	Structural Design and Drawing –III (401003)
Friday 22.10.2021	<b><u>Elective – I ( 401004 )</u></b> a) Structural Design of Bridges b) System Approach in Civil Engineering c) Advanced Concrete Technology d) Architecture and Town Planning e) Advanced Engineering Geology with Rock Mechanics	<b><u>Elective – I ( 401004 )</u></b> a) Structural Design of Bridges b) System Approach in Civil Engineering c) Advanced Concrete Technology d) Architecture and Town Planning e) Advanced Engineering Geology with Rock Mechanics

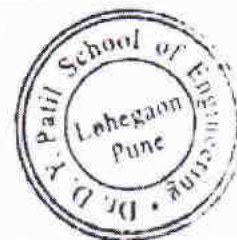

<p>Saturday (23.10.2021)</p>	<p align="center"><b><u>Elective – II (401005)</u></b></p> <p>a) Matrix Methods of Structural Analysis</p> <p>b) Integrated Water Resources and Planning</p> <p>c) TQM &amp; MIS in Civil Engineering</p> <p>d) Earthquake Engineering</p> <p>e) Advanced Geotechnical Engineering</p>	<p align="center"><b><u>Elective – II (401005)</u></b></p> <p>a) Matrix Methods of Structural Analysis</p> <p>b) Integrated Water Resources and Planning and Management</p> <p>c) TQM &amp; MIS in Civil Engineering</p> <p>d) Earthquake Engineering</p> <p>e) Advanced Geotechnical Engineering</p>
----------------------------------	--	---

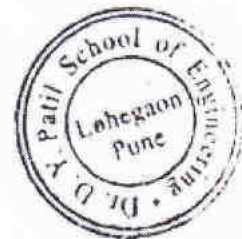

# B.E. (COMPUTER ENGINEERING)

SEMESTER-I

Time – 02:30 to 04.00 p.m.

Day & Date	SUBJECT (2012 Course)	SUBJECT (2015 Course)
Monday 18.10.2021	Design & Analysis of Algorithms ( 410441 )	High Performance Computing ( 410241 )
Wednesday 20.10.2021	Principles of Modern Compiler Design ( 410442)	Artificial Intelligence and Robotics (410242)
Thursday 21.10.2021	Smart System Design and Applications ( 410 443)	Data Analytics (410243)
Friday 22.10.2021	<b><u>Elective – I ( 410444)</u></b> a) Image Processing b) Computer Network Design and Modeling, c) Advanced Computer Programming, d) Data Mining Techniques and Applications.	<b><u>Elective – I ( 410244)</u></b> a) Digital Signal Processing b) Software Architecture and Design c) Pervasive and Ubiquitous Computing d) Data Mining and Warehousing
Saturday 23.10.2021	<b><u>Elective – II (410445)</u></b> a) Problem Solving with Gamification b) Pervasive Computing c) Embedded Security d) Multidisciplinary NLP	<b><u>Elective – II (410245)</u></b> a) Distributed Systems b) Software Testing and Quality Assurance c) Operation Research d) Mobile Communications



## B.E. (MECHANICAL)

SEMESTER-I

Time – 03.30 to 05.00 p.m.

Day & Date	SUBJECT (2012 Course)	SUBJECT (2015 Course)
Monday 18.10.2021	Refrigeration and Air Conditioning (402041)	Hydraulics and Pneumatics (402041) Refrigeration and Air Conditioning
Wednesday 20.10.2021	CAD/CAM Automation (402042)	CAD/CAM Automation (402042)
Thursday 21.10.2021	Dynamics of Machinery (402043)	Dynamics of Machinery (402043)
Friday 22.10.2021	<b><u>Elective – I (402044)</u></b> a) Energy Audit Management b) Tribology c) Reliability Engineering d) Machine Tool Design	<b><u>Elective – I (402044)</u></b> a) Finite Element Analysis b) Computational Fluid Dynamics c) Heating Ventilation and Air Conditioning
Saturday 23.10.2021	<b><u>Elective – II (402045)</u></b> a) Gas Turbine Propulsion b) Product Design and Development c) Operation Research d) Advanced Manufacturing Processes	<b><u>Elective – II (402045)</u></b> a) Automobile Engineering b) Operation Research c) Energy Audit and Management

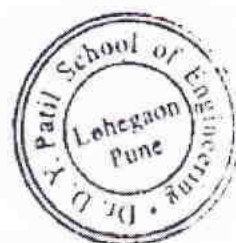

# B.E. (ELECTRONICS & TELECOMMUNICATIONS)

SEMESTER-I

Time – 02:30 to 04.00 p.m.

Day & Date	SUBJECT (2012 Course)	SUBJECT (2015 Course)
Monday 18.10.2021	VLSI Design & Technology (404181)	VLSI Design & Technology (404181)
Wednesday 20.10.2021	Computer Networks (404182)	Computer Networks and Security (404182)
Thursday 21.10.2021	Microwave Engineering ( 404183)	Radiation and Microwave Techniques (404183)
Friday 22.10.2021	<b><u>Elective – I (404184)</u></b> a) Digital Image Processing b) Embedded System and RTOS c) Software Defined Radio d) Industrial Drives and Control	<b><u>Elective – I (404184)</u></b> a) Digital Image and Video Processing b) Industrial Drives and Control c) Embedded System and RTOS d) Internet of Things
Saturday 23.10.2021	<b><u>Elective – II -( 404185 )</u></b> a) Multi rate & Adaptive Signal Processing b) Electronic Product Design c) PLCs and Automation d) Artificial Intelligence	<b><u>Elective – II -( 404185 )</u></b> a) Wavelets b) Electronic Product Design c) Optimization Techniques d) Artificial Intelligence e) Electronics in Agriculture

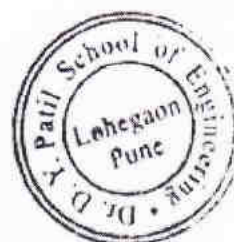

Dr. D. Y. Patil Technical Campus

# **Dr. D. Y. Patil School of Engineering**

Dr. D. Y. Patil Knowledge City, Charholi (Bk), Lohegaon, Pune – 412 105

## 8) Question Bank





Dr. D. Y. Patil Group of Institutions' Technical  
Campus  
**Dr. D. Y. PATIL SCHOOL OF ENGINEERING**  
Dr. D. Y. Patil Knowledge City, Charholi Bk., Via.  
Lohegaon, Pune - 412 105.  
**Department of Civil Engineering**

**Question bank on unit . 5**

**A.Y.: 2020-21**

**Semester: III**

**Class: SE**

**Div: A**

**Name of Subject: Fluid Mechanics**

<b>Sr. No.</b>	<b>Question</b>
1	Write Darcy Weisbach equation and explain the terms?
2	What is Moody's diagram?
3	Explain Dupits's equation
4	Write short note on syphon?
5	Differentiate between flow through pipes in series and parallel.
6	What is Prandtl's mixing length theory?
7	Enlist different losses through pipe
8	For a laminar flow Reynolds number is 999 calculate friction factor and coefficient of friction
9	Short note on Nikurdse's equation
10	What is smooth boundary and rough boundary for a flow through pipe?



Subject Teacher  
Prof. Uzma Shaikh

HOD

Prof. S. M Karodpati



H.O.D.

Department of Civil Engineering  
Dr. D. Y. Patil School of Engg. Lohegaon





Dr. D. Y. Patil Group of Institutions' Technical Campus  
**Dr. D. Y. PATIL SCHOOL OF ENGINEERING**  
Dr. D. Y. Patil Knowledge City, Charholi Bk., Via. Lohegaon, Pune - 412 105.  
Department of E&TC Engineering

**Question Bank (Theory)**

**A. Y.: 2020-21**

**Semester: II**

**Class: B.E.**

**Name of Subject: Broadband Communication System**

Question Number	Question	Marks
1.	What are Optical Transmitters? Explain with diagram working of LED with its characteristics. State its specifications & limitations over LASER.	
2.	What are the key requirements of point to point link in FOC? Explain link design with respect to choice of components & its characteristics.	
3.	Explain Rise time budget in OFC systems.	
4.	What is Multichannel Transmission System? Explain with diagram Multi-channel Amplitude Modulation technique.	
5.	What is EDFA? Explain the principle & operation of EDFA.	
6.	Compare PIN photo diode with APD.	
7.	What is the need of satellite communication? Explain with diagram basic structure of satellite communication.	
8.	What are the various orbital effects in communication system performance? Explain.	
9.	Explain with relevant details, satellite communication link design. Comment on important issues in Link design.	



10.	What is link budget? Explain performance objective for Digital Link. Derive the equation for Received power ' $P_r$ '.	
11.	What is Reliability & Space qualification? Explain with bath tub curve.	
12.	What is TTC? Explain in brief.	
13.	What is look angle determination? Explain.	
14.	Explain with diagram Uplink design of satellite communication.	
15.	Compare LEO, MEO, GEO satellite orbits.	
16.	What LNA? Explain.	
17.	What is system noise temperature & $\frac{G}{T}$ Ratio? Explain in detail.	
18.	State & explain the design considerations for downlink design of satellite communication.	
19.	Write short notes Satellite Antennas.	
20.	Write short notes Synchronous satellites.	
21.	What is equivalent Isotropic Radiated Power? (EIRP) explain in brief.	
22.	What are photodetectors? Explain with diagram working of Avalanche photodiode (APD).	
23.	What is linear scattering? Explain in brief. i) Rayleigh Scattering? ii) Mie Scattering.	
24.	What are graded index fibers? Explain with diagram how does ray transmission takes place in the graded Index Multimode fiber.	



25.	A Multimode Graded index fiber exhibits total pulse broadening of 0.1 $\mu$ sec over a distance of 15km. Estimate. i) The maximum possible Band width on the Link assuming no inter symbol Interference. ii) The pulse dispersion per unit length iii) the Bandwidth length product for the fiber.	
26.	What are various types of optical sources? Explain with diagram and characteristics working of LED. State its specifications, advantages and disadvantages.	
27.	What is EDFA? Explain.	
28.	What is the need of optical power budget? Explain Link power budget with the help of optical power loss model for a point to point communication.	
29.	What is multichannel transmission in optical (fibers) links? Explain any one method to achieve multichannel transmission.	
30.	What are the Elements of satellite communication? Explain with basic structure of satellite communication.	
31.	Compare LEO, MEO, & GEO satellite orbits with its application.	
32.	Explain various Look angles for satellite communication.	
33.	Describe the Launch sequence used in Inject satellite.	
34.	What are various losses in uplink and downlink analysis? Explain.	
35.	What are orbital effects in communication system performance? Explain	
36.	What are different types of Antennas used in satellite systems? Explain importance of each.	
37.	Explain the following i) Communication subsystem.	
38.	Explain Antenna subsystem.	



39.	Explain the procedure for satellite communication link Design	
40.	Explain any two. i) Attitude control system. ii) Orbital control system. iii) Tracking, telemetry and command system.	
41.	State and Explain Kepler's three Laws of planetary motion.	
42.	Explain advantages of optical fibers as communication media. Also state its drawbacks if any.	
43.	Define cut off wavelength of a single mode fiber. Determine the cutoff wavelength for a step index fiber to exhibit single-mode operation when the core refractive index and radius are 1.46 and 4.5 $\mu\text{m}$ , respectively, with the relative index difference being 0.25%. Assume $V_c = 2.405$ .	
44.	A multimode step index fiber has a relative refractive index difference of 1% and a core refractive index of 1.5. The number of modes propagating at a wavelength of 1.3 $\mu\text{m}$ is 1100. Estimate the diameter of the fiber core	
45.	Describe working principle with the aid of simple ray diagram i) Multimode Step Index Fiber ii) Graded Index Fiber Compare advantages and drawbacks of these fibers. Draw a diagram indicating major possible fiber refractive index profiles for the profile parameter $\alpha = 1, 2$ and $\infty$ .	



46.	<p>An optical fiber system is to be designed to operate over an 8 km length without repeaters. The rise times of the chosen components are:</p> <p>Source (LED): 8 ns</p> <p>Fiber: intermodal <math>5 \text{ ns km}^{-1}</math></p> <p>(pulse broadening) intra-modal: <math>1 \text{ ns km}^{-1}</math></p> <p>Detector (<i>p-i-n</i> photodiode): 6 ns</p> <p>From system rise time considerations, estimate the maximum bit rate that may be achieved on the link when using an NRZ format.</p>	
47.	Compare and contrast <i>p-i-n</i> and avalanche photo detectors as optical detector for optical fiber communication.	
48.	<p>Compare the following optical amplifiers based on working principle, amplification gain and drawbacks.</p> <p>i) SOA</p> <p>ii) EDFA</p>	
49.	Compare and contrast LED and ILD as optical source for optical fiber communication.	
50.	Which orbital parameter completely specify the orbit? Briefly describe each one of these.	
51.	Verify that geostationary satellite needs to be at a height of about 35780 km above the surface of the Earth. Assume radius of earth to be 6380 km and $\mu = 39.8 \times 10^{13} \text{ Nm}^2/\text{kg}$ .	
52.	Explain briefly various look angles for satellite earth station.	
53.	How does solar eclipse affect satellite communication?	
54.	Determine the maximum possible line of sight distance between two geostationary satellites orbiting the earth at a height of 36000 km above the surface of the Earth. Assume radius of earth to be 6380 km.	



55.	Describe the launch sequence used to inject satellite.	
56.	What are the different components of satellite's power supply subsystem? Briefly describe the role of each component.	
57.	Explain in detail any two of the following for orbital satellite i) Communication Subsystem ii) Antenna Subsystem	
58.	Explain double conversion transponder for 14/11 GHz band. Support your answer with suitable diagram and specify frequencies of local oscillators and IF amplifiers.	
59.	Explain Bath-tub curve for probability of failure with reference to satellite. Hence define MTBF. State relation of MTBF with probability of device failure.	
60.	Explain various redundancy connections used to mitigate device failure.	
61.	<p>a) A 4 GHz receiver has the following gains and noise temperatures  <math>T_m = 25 \text{ K}</math>, <math>T_{RF} = 50 \text{ K}</math>, <math>T_{IF} = 1000 \text{ K}</math>, <math>T_m = 500 \text{ K}</math>, <math>G_{RF} = 23 \text{ dB}</math>, <math>G_{IF} = 30 \text{ dB}</math>.</p> <p>i) Calculate the system noise temperature assuming that the mixer has a gain <math>G_m = 0 \text{ dB}</math>.</p> <p>ii) Recalculate the system noise temperature when the mixer has a 10 dB loss.</p> <p>iii) How can the noise temperature of the receiver be minimized when the mixer has a loss of 10 dB?</p> <p>iv) The system has an LNA with a gain of 50 dB. A section of lossy waveguide with an attenuation of 2 dB is inserted between the antenna and the RF amplifier. Find the new system noise temperature for a waveguide temperature of <math>300^\circ \text{ K}</math>.</p>	





62.	What do you understand by link budget of a satellite communication link? What type of information do you get from such an analysis'?	
63.	Explain various losses in downlink analysis.	
64.	A transponder of a Ku-band satellite has a linear gain of 127 dB and a nominal output power at saturation of 5 W. The satellite's 14 GHz receiving antenna has a gain of 26 dB on axis. Calculate the power output of an uplink transmitter that gives an output power of 1 W from the satellite transponder at a frequency of 14.45 GHz when the earth station antenna has a gain of 50 dB and there is a 1.5 dB loss in the waveguide run between the transmitter and antenna. Assume that the atmosphere introduces a loss of 0.5 dB under clear sky conditions and that the earth station is located on the -2 dB contour of the satellite's receiving antenna. If the rain in the path causes attenuation of 7 dB for 0.01% of the year, what output power rating is required for the transmitter to guarantee that a 1 W output can be obtained from the satellite transponder for 99.99% of the year if uplink power control is used?	

Prpared by

Prof. Prajakta Khairnar



8

	<p>Dr. D. Y. Patil Group of Institutions' Technical Campus <b>Dr. D. Y. PATIL SCHOOL OF ENGINEERING</b> Dr. D. Y. Patil Knowledge City, Charholi Bk., Via. Lohegaon, Pune – 412 105. Department of Mechanical Engineering</p> <p>Form No. IQAC/</p>
---	---

**Oral Questions**

Sr. No.	Questions	
1	Which fluid is used in hydraulic power systems?	
2	Pressure of 1 bar is equal to	
3	Why is fluid power preferred in mobile vehicles?	
4	What effect does overloading have on fluid power and electrical systems?	
5	How is power transmitted in fluid power systems?	
6	Can all hydraulic fluids be compressed when extremely large pressure is applied?	
7	The resistance offered to the flow of fluid inside a piston develops into	
8	At low pressures, liquids are	
9	Which fluid is used in hydraulic power systems?	
10	Pressure of 1 bar is equal to	
11	Why is fluid power preferred in mobile vehicles?	
12	What effect does overloading have on fluid power and electrical systems?	
13	How is power transmitted in fluid power systems?	
14	Can all hydraulic fluids be compressed when extremely large pressure is applied?	
15	The resistance offered to the flow of fluid inside a piston develops into	
16	At low pressures, liquids are	
17	Rotary motion in a hydraulic power unit is achieved by using	
18	What is the relation between speed and flow rate for fixed displacement vane pump?	
19	In fixed displacement vane pump,	
20	Which type of motion is transmitted by hydraulic actuators?	
21	What is the function of electric actuator?	
22	What is the advantage of using a single acting cylinder?	
23	What is the function of a flow control valve?	
24	What does the numbers in 4/2 valve mean?	
25	Which of the following gas is used in gas charged accumulator?	
26	Which of the following is a component used in air generation system?	
27	Which of the following logic valve is known as shuttle valve?	
28	What is a pressure sequence valve?	

  
Subject Teacher





Dr. D. Y. Patil Group of Institutions' Technical Campus  
**Dr. D. Y. PATIL SCHOOL OF ENGINEERING**  
Dr. D. Y. Patil Knowledge City, Charholi Bk., Via. Lohegaon, Pune - 412 105.  
Department of Mechanical Engineering

Form No. IQAC/29 (h)

## Question Bank

Question Number	Question	Marks
1	Explain end cushioning provided in hydraulic cylinder with neat sketch.	6
2	Classify and explain hydraulic accumulators.	6
3	Name three important mountings in hydraulic system with neat sketch.	3
OR		
4	Explain with the help of hydraulic circuit use of accumulator as a shock absorber	6
5	An 8 cm diameter of cylinder has 4cm diameter of rod. If the cylinder receives flow at 100 LPM and 12Mpa , find the actuator speed and load carrying capacity in; i. Extension stroke ii. Retraction stroke	6
6	What is the function of breather assembly in hydraulic reservoir?	3
7	Draw simple sketch of pressure relief valve and explain its function	6
8	Classify different types of direction control valve. Draw ISO symbols	6
9	Draw ISO symbol for following components; i. Quick Exhaust valve ii. Pressure and temperature compensated valve iii. Pressure reducing valve	3
OR		
10	Draw and explain the following with their application in circuit. i. Three way two positioned direction control valve ii. Four way three positioned direction control valve (closed center)	6



11		Explain with neat sketch any three methods of DCV actuation.	6
12		Classify different types of pressure control valves used for hydraulic. Draw ISO symbol of each.	3
13		With neat diagram discuss gear pump	6
14		Draw ISO symbols for given component i. Pressure and temperature compensated valve ii. Pressure relief valve iii. Quick Exhaust valve iv. Unidirectional hydraulic motor v. Spring loaded accumulator vi. F-R-L Unit	6
15		State and Explain Pascal's law.	3
16		Classify hydraulic Pumps & define various efficiencies of a pump	6
17		The displacement of pump operating at 1000rpm at a pressure of 10bar is 100cm. The input torque from prime mover is 120 nm. If it delivers 0.0015 m <sup>3</sup> /s of oil. Then determine i. Overall efficiency of the pump ii. Theoretical torque required to operate through pump iii. Volumetric efficiency	6
18		Explain advantages of hydraulic system over mechanical & electrical system.	3



Subject Teacher



Dr. D. Y. Patil Technical Campus

# Dr. D. Y. Patil School of Engineering

Dr. D. Y. Patil Knowledge City, Charholi (Bk), Lohegaon, Pune – 412 105

9) Question Papers



Dr. D. Y. Patil Group of Institutions' Technical Campus  
**Dr. D. Y. PATIL SCHOOL OF ENGINEERING**  
Dr. D. Y. Patil Knowledge City, Charholi Bk., Via. Lohegaon, Pune – 412 105.  
Department of Mechanical Engineering

**Unit Test (II) Question Paper**

A.Y.: 2020-2021

Semester: I

Class: BE Div: I

Name of Subject: Hydraulics and Pneumatics

Date of Examination: 31/10/2020

Total Marks: 30

Duration: 1hr

**Instructions (if any):**

1. Assume suitable data, if necessary.
2. Neat diagrams must be drawn wherever necessary.

Question Number	Question	Marks	
1	A	Draw simple sketch of pressure relief valve and explain its function	6
	B	Classify different types of direction control valve. Draw ISO symbols	6
	C	Draw ISO symbol for following components; i. Quick Exhaust valve ii. Pressure and temperature compensated valve iii. Pressure reducing valve	3
OR			
2	A	Draw and explain the following with their application in circuit. i. Three way two positioned direction control valve ii. Four way three positioned direction control valve (closed center)	6
	B	Explain with neat sketch any three methods of DCV actuation.	6
	C	Classify different types of pressure control valves used for hydraulic. Draw ISO symbol of each.	3



Question Number		Question	Marks
3	A	Draw regenerative circuit used for drilling application	6
	B	Draw and explain Sequencing circuit	6
	C	Draw and explain Bleed-off speed control circuit and its application	3
OR			
4	A	Draw and explain counter balance circuit	6
	B	Draw and explain Fail safe circuit and its application	6
	C	Draw and explain Meter-In speed control circuit and its application	3





Dr. D. Y. Patil Group of Institutions' Technical Campus  
**Dr. D. Y. PATIL SCHOOL OF ENGINEERING**  
Dr. D. Y. Patil Knowledge City, Charholi Bk., Via. Lohegaon, Pune - 412 105.  
Department of Mechanical Engineering

**Unit Test (I) Question Paper**

**Semester: I**  
**Hydraulics and Pneumatics**

**Class: BE**

**Name of Subject:**

**Total Marks: 30 Duration: 1hr**

**Instructions (if any):**

1. Assume suitable data, if necessary.
2. Neat diagrams must be drawn wherever necessary.

Question Number	Question	Marks
1	A With neat diagram discuss gear pump	6
	B Draw ISO symbols for given component i. Pressure and temperature compensated valve ii. Pressure relief valve iii. Quick Exhaust valve iv. Unidirectional hydraulic motor v. Spring loaded accumulator vi. F-R-L Unit	6
	C State and Explain Pascal's law.	3
OR		
2	A Classify hydraulic Pumps & define various efficiencies of a pump	6
	B The displacement of pump operating at 1000rpm at a pressure of 10bar is 100cm. The input torque from prime mover is 120 nm. If it delivers 0.0015 m <sup>3</sup> /s of oil. Then determine i. Overall efficiency of the pump ii. Theoretical torque required to operate through pump iii. Volumetric efficiency	6
	C Explain advantages of hydraulic system over mechanical & electrical system	3





Question Number		Question	Marks
1	A	Explain end cushioning provided in hydraulic cylinder with neat sketch.	6
	B	Classify and explain hydraulic accumulators.	6
	C	Name three important mountings in hydraulic system with neat sketch.	3
OR			
2	A	Explain with the help of hydraulic circuit use of accumulator as a shock absorber	6
	B	An 8 cm diameter of cylinder has 4cm diameter of rod. If the cylinder receives flow at 100 LPM and 12Mpa , find the actuator speed and load carrying capacity in; i. Extension stroke ii. Retraction stroke	6
	C	What is the function of breather assembly in hydraulic reservoir?	3



Dr. D. Y. Patil Technical Campus

# **Dr. D. Y. Patil School of Engineering**

Dr. D. Y. Patil Knowledge City, Charholi (Bk), Lohegaon, Pune – 412 105

## **10) Activity Planning**

1.1.1-10

Department Vision: - To impart and inculcate excellence in Technical knowledge and skills to secure socio-economic conditions.

<b>Dr. D Y PATIL SCHOOL OF ENGINEERING</b>		
<b>Department of Computer Engineering</b>		
<b>Class: B.E - A</b>	<b>Artificial Intelligence and Robotics</b>	<b>Sem-VII</b>
<b>TEACHING PLAN (AY 2020-21)</b>		<b>Form No.: IQAC/4</b>
<b>Lectures per Week : 03</b>		<b>Subject In-charge : Dr. Sunil D Rathod</b>
<b>Text Books:</b>		
1. Deepak Khemani, "A First Course in Artificial Intelligence", McGraw Hill Education(India), 2013, ISBN : 978-1-25-902998-1		
2. Elaine Rich, Kevin Knight and Nair, "Artificial Intelligence", TMH, ISBN-978-0-07-008770-5		
3. Stuart Russell and Peter Norvig, "Artificial Intelligence: A Modern Approach", Third edition, Pearson, 2003, ISBN :10: 0136042597		
4. Michael Jenkin, Gregory, " Computational Principals of Mobile Robotics", Cambridge University Press, 2010, ISBN : 978-0-52-187157-0		
<b>Reference books:</b>		
1. Nilsson Nils J , "Artificial Intelligence: A new Synthesis, Morgan Kaufmann Publishers Inc. San Francisco, CA, ISBN: 978-1-55-860467-4		
2. Patrick Henry Winston, "Artificial Intelligence", Addison-Wesley Publishing Company, ISBN: 0-201-53377-		
3. Andries P. Engelbrecht-Computational Intelligence: An Introduction, 2nd Edition-Wiley India- ISBN: 978-0-470-51250-0		

Lect No.	Unit No.	Planned Date	BROAD TOPICS TO BE COVERED	SUB TOPICS AND DETAILS THEREOF TO BE COVERED	Actual date of conduction	Suggested Books (Page Nos.)	Remark
1.	<b>1</b>	06/07/2020	<b>Introduction</b>	Artificial Intelligence: Introduction, Typical Applications	16/07/2020	T1- Ch2 (7-39)	
2.		09/07/2020		State Space Search: Depth Bounded DFS, Depth First Iterative Deepening	20/07/2020	R1-Ch3 (67-101)	
3.		11/07/2020		Heuristic Search: Heuristic Functions, Best First Search	23/07/2020	T1-Ch2 (41-57) R1-Ch3 (73-89)	
4.		13/07/2020		Hill Climbing, Variable Neighborhood Descent	27/07/2020	T1-Ch2 (41-57) R1-Ch3 (73-89)	

- Mission: -**
1. To develop excellent learning center through continuous up gradation in technologies in proximity with Academia, R&D centers and Industries.
  2. To pursue research of local and global relevance.
  3. To encourage students to consider "startups" as a career option through Entrepreneurship Development Cell.
  4. Uplift and groom the learners to emerge as committed professionals.



Department Vision: - To impart and inculcate excellence in Technical knowledge and skills to secure socio-economic conditions.

5.		15/07/2020		Beam Search, Tabu Search	30/07/2020	T1-Ch2 (60-70) R1-Ch3 (92-117)	
6.		18/07/2020		Optimal Search: A* algorithm, Iterative Deepening A*	06/08/2020	T1-Ch2 (71-93) R1-Ch3 (120-132)	
7.		20/07/2020		Recursive Best First Search	10/08/2020	T1-Ch2 (71-93) R1-Ch3 (120-132)	
8.		22/07/2020		Pruning the CLOSED and OPEN Lists.	27/08/2020	T1-Ch2 (71-93) R1-Ch3 (120-132)	
9.	2	25/07/2020	<b>Problem Decomposition and Planning</b>	Problem Decomposition: Goal Trees	29/08/2020	T1- Ch6 (156-170)	
10.		29/07/2020		Rule Based Systems, Rule Based Expert Systems	31/08/2020	T1- Ch6 (156-170)	
11.		03/08/2020		Planning: STRIPS, Forward and Backward State Space Planning	05/09/2020	T1- Ch7 (180-195)	
12.		08/08/2020		Goal Stack Planning, Plan Space Planning	10/09/2020	T1- Ch7 (198-215)	
13.		10/08/2020		A Unified Framework For Planning. Constraint Satisfaction : N-Queens	12/09/2020	T1- Ch7 (198-215)	
14.		13/08/2020		Constraint Propagation, Scene Labeling	14/09/2020	T1- Ch9 (321-345)	
15.		17/08/2020		Higher order and Directional Consistencies	17/09/2020	T1- Ch9 (350-395)	
16.		20/08/2020		Backtracking and Look ahead Strategies	19/09/2020	T1- Ch9 (350-395)	

Mission: - 1.To develop excellent learning center through continuous up gradation in technologies in proximity with Academia, R&D centers and Industries.

2. To pursue research of local and global relevance.

3. To encourage students to consider "startups" as a career option through Entrepreneurship Development Cell.

4. To lift and groom the learners to emerge as committed professionals

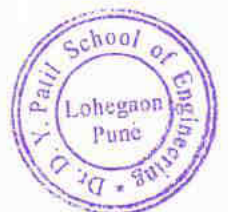

Department Vision: - To impart and inculcate excellence in Technical knowledge and skills to secure socio-economic conditions.

17.	3	22/08/2020	Logic and Reasoning	Knowledge Based Reasoning: Agents, Facets of Knowledge	21/09/2020	T2-Ch2 (75-89)	
18.		24/08/2020		Logic and Inferences: Formal Logic	26/09/2020	T2-Ch2 (91-137)	
19.		27/08/2020		Propositional and First Order Logic	28/09/2020	T2-Ch2 (141-159)	
20.		29/08/2020		Resolution in Propositional and First Order Logic	28/09/2020	T2-Ch2 (141-159)	
21.		31/08/2020		Deductive Retrieval, Backward Chaining	29/09/2020	T2-Ch2 (141-159)	
22.		03/09/2020		Second order Logic	01/10/2020	T2-Ch2 (45-74)	
23.		05/09/2020		Knowledge Representation: Conceptual Dependency	03/10/2020	T2-Ch2 (45-74)	
24.		07/09/2020		Frames, Semantic nets	05/10/2020	T2-Ch2 (45-74)	
25.		4		10/09/2020	Natural Language Processing and ANN	Natural Language Processing: Introduction	08/10/2020
26.	12/09/2020		Stages in natural language Processing	08/10/2020		T1- Ch9 (321-345)	
27.	17/09/2020		Application of NLP in Machine Translation	12/10/2020		T1- Ch9 (321-345)	
28.	19/09/2020		Information Retrieval and Big Data Information Retrieval	12/10/2020		T1- Ch9 (350-395)	
29.	21/09/2020		Learning: Supervised, Unsupervised and Reinforcement learning	19/10/2020		T1- Ch9 (350-395)	
30.	24/09/2020		Artificial Neural Networks (ANNs): Concept	22/10/2020		T2-Ch7 (22-79) R2-Ch1 (91-118)	
31.	26/09/2020		Feed forward and Feedback ANNs	24/10/2020		T2-Ch7 (22-79) R2-Ch1 (91-118)	

Mission: - 1.To develop excellent learning center through continuous up gradation in technologies in proximity with Academia, R&D centers and Industries.

2. To pursue research of local and global relevance.

3. To encourage students to consider "startups" as a career option through Entrepreneurship Development Cell.

4. Unlift and groom the learners to emerge as committed professionals.

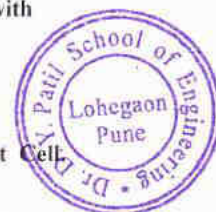

Department Vision: - To impart and inculcate excellence in Technical knowledge and skills to secure socio-economic conditions.

32.		28/09/2020		Error Back Propagation, Boltzmann Machine	24/10/2020	T2-Ch7 (96-126) R2-Ch1 (119-138)	
33.	5	01/10/2020	Robotics	Robotics: Fundamentals, path Planning for Point Robot	29/10/2020	T3-Ch1 (11-26)	
34.		03/10/2020		Sensing and mapping for Point Robot	31/10/2020	T3-Ch1 (41-66)	
35.		05/10/2020		Mobile Robot Hardware, Non Visual Sensors like: Contact Sensors	31/10/2020	T4-Ch1 (76-81)	
36.		10/10/2020		Inertial Sensors, Infrared Sensors	02/11/2020	T4-Ch1 (76-81)	
37.		12/10/2020		Radar, laser Rangefinders, Biological Sensing	05/11/2020	T4-Ch1 (86-110)	
38.		15/10/2020		Robot System Control: Horizontal and Vertical Decomposition	07/11/2020	T4-Ch1 (86-110)	
39.		17/10/2020		Hybrid Control Architectures	07/11/2020	T4-Ch1 (86-110)	
40.		19/10/2020		Middleware, High-Level Control, Human-Robot Interface.	09/11/2020	T4-Ch1 (120-139)	

Mission: - 1. To develop excellent learning center through continuous up gradation in technologies in proximity with Academia, R&D centers and Industries.

2. To pursue research of local and global relevance.

3. To encourage students to consider "startups" as a career option through Entrepreneurship Development Cell.

4. To uplift and groom the learners to emerge as committed professionals.



Department Vision: - To impart and inculcate excellence in Technical knowledge and skills to secure socio-economic conditions.

41.	6	22/10/2020	Robots in Practice	Robot Pose Maintenance and Localization: Simple Landmark Measurement	09/11/2020	T4-Ch4 (140-159) T3-Ch4 (160-179)	
42.		24/10/2020		Servo Control, Recursive Filtering	09/11/2020	T4-Ch4 (180-139)	
43.		26/10/2020		Global Localization. Mapping: Sensorial Maps	09/11/2020	T4-Ch4 (180-139)	
44.		29/10/2020		Topological Maps, Geometric Maps	19/11/2020	T4-Ch4 (120-199)	
45.		31/10/2020		Exploration. Robots in Practice: Delivery Robots	19/11/2020	T4-Ch4 (201-213)	
46.		02/11/2020		Intelligent Vehicles, Mining Automation	19/11/2020	T4-Ch4 (214-218)	
47.		04/11/2020		Space Robotics, Autonomous Aircrafts	21/11/2020	T4-Ch4 (218-239)	
48.		07/11/2020		Agriculture, Forestry, Domestic Robots	21/11/2020	T4-Ch4 (218-239)	



**Prof. Sunil Rathod**  
Subject In-charge



**Dr. Pankaj Agarar**  
HOD



**Dr F B Sayyad**  
Principal

**Head of the Department**  
Department of Computer Engineering  
Dr. D. Y. Patil School of Engineering  
Dr. D. Y. Patil Technical Campus  
Via Lohegaon, Charholi Bk., Pune-412 105

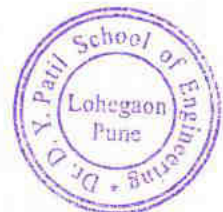

- Mission: - 1. To develop excellent learning center through continuous up gradation in technologies in proximity with Academia, R&D centers and Industries.
2. To pursue research of local and global relevance.
  3. To encourage students to consider "startups" as a career option through Entrepreneurship Development Cell.
  4. Unlift and groom the learners to emerge as committed professionals

Vision: - "EMPOWERMENT THROUGH ACADEMIC EXCELLENCE"

**Dr. D. Y. Patil School of Engineering, Pune -412 105**

Department of Mechanical Engineering

Class: T.E.( Div.:

**Mechatronics**

Semester: V

**TEACHING PLAN**

Lectures per Week: 03

Subject In charge: Kunal Marathe

**Text Books:**

1. K.P. Ramchandran, G.K. Vijayaraghavan, M.S. Balasundaram, Mechatronics: Integrated Mechanical Electronic Systems, Willey Publication, 2008.
2. Bolton, Mechatronics -A Multidisciplinary approach, 4th Edition, Prentice Hall, 2009.

**References:**

1. Mahalik, Mechatronics –Principles, concepts and applications, Tata Mc-Graw Hill publication, New Delhi.
2. C. D. Johnson, Process Control Instrumentation Technology, Prentice Hall, New Delhi.

Lect. No	Unit No	Planned Date	BROAD TOPICS TO BE COVERED	SUB TOPICS AND DETAILS THERE OF TO BE COVERED	Actual Date of Conduction	Suggested Books	Remark
						(Page Nos.)	
1	1	19.08.2021	<b>Introduction to Mechatronics, Sensors &amp; Actuators</b>	Introduction to Mechatronics and its Applications Measurement Characteristics (Static/Dynamic).		T1-Ch1	
2		20.08.2021		Sensors Introduction and Types of sensors, <b>Motion Sensors</b> – Encoder (Absolute & incremental), Lidar, Eddy Current.		P(1-3)	
3		23.08.2021		<b>Proximity sensors</b> (Optical, Inductive, Capacitive), MEMS Accelerometer.		T1- Ch1 P(14-20)	
4		26.08.2021		<b>Temperature sensor</b> –Pyrometer, Infrared Thermometer; <b>Force / Pressure Sensors</b> – Strain gauges, Piezoelectric sensor.		T1- Ch15 P(561-569)	
5		27.08.2021		<b>Flow sensors</b> – Electromagnetic, Ultrasonic, Hot-wire anemometer; <b>Color sensor</b> – RGB type, <b>Biosensors</b> – Enzyme, ECG, EMG.		R2- Ch13 P(422-424)	
6		30.08.2021		<b>Actuators:</b> Servo motor; Hydraulic and Pneumatic (must be restricted to classification and working of one type of linear and rotary actuator).		T1- Ch1	
7		02.09.2021		Linear electrical actuators Selection of Sensor & Actuator.		(5-11)	
8		03.09.2021		<b>Signal Communication:</b> Serial, Parallel; Synchronous, Asynchronous, Introduction to DAQ, Types.		T1- Ch1 P(20-22)	





9	2	06.09.2021	<b>Data Acquisition and Signal Communication</b>	Components of a Data Acquisition System (Sensor, Signal conditioning, processing, controlling and storage/display/action).		T2- Ch1 P(15,20-22)	
10	09.09.2021	<b>Data Acquisition:</b> Signal collection, <b>Signal conditioning</b> – Isolation & Filtering, Amplification.			T2- Ch1 P(15,20-22)		
11	10.09.2021	Sampling, Aliasing, Sample and hold circuit, Quantization.			T1 Ch1		
12	13.09.2021	Analog-to-digital converters (4 bit Successive Approximation type ADC).			P(29-31)		
13	16.09.2021	Digital-to-Analog converters (4 bit R2R type DAC).			T1 Ch1		
14	17.09.2021	Data storage Applications: DAQ in Household, Digital Pressure Gauge, Digital Flow measurement.			P(32-38)		
15	20.09.2021	Data storage Applications: DVB Digital Video Broadcast, AM/FM			T1 Ch2		
16	23.09.2021	<b>Control systems &amp; transfer function based modelling</b>		Introduction to control systems, need, Types- Open and Closed loop, Concept of Transfer Function.		P(41-44)	
17	24.09.2021		Block Diagram & Reduction principles and problems		R2 Ch16		
18	27.09.2021		Problems on Block Diagram Reduction		P(682-683)		
19	30.09.2021		Applications (Household, Automotive, Industrial shop floor).		T1 Ch2		
20	01.10.2021		Transfer Function based modeling of Mechanical, Thermal and Fluid system.		P(48-51)		
21	04.10.2021		Concept of Poles & Zeros; Pole zero plot, Stability Analysis using Routh Hurwitz Criterion.		T1 Ch2		
22	07.10.2021		Numericals on Stability Analysis.		P(45-47)		
23	08.10.2021		<b>Time and Frequency Domain Analysis</b>	Time Domain Analysis – Unit step Response analysis via Transient response specifications (Percentage overshoot, Rise time, Delay time, Steady state error).		T1 Ch2	
24	11.10.2021	Time Domain Analysis – Unit step Response analysis via Transient response specifications (Percentage overshoot, Rise time, Delay time, Steady state error).			P(51-58)		
25	14.10.2021	Time Domain Analysis – Unit step Response analysis via Transient response specifications (Percentage overshoot, Rise time, Delay time, Steady state error).			T1 Ch3		

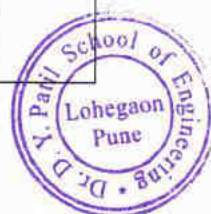

			analysis			
26		14.10.2021		Frequency Domain Analysis – Frequency Domain Parameters - Natural Frequency, Damping Frequency and Damping Factor.		P(61-62)
27		15.10.2021		Frequency Domain Analysis – Frequency Domain Parameters - Natural Frequency, Damping Frequency and Damping Factor.		T1 Ch3
28		18.10.2021		Mapping of Pole Zero plot with damping factor.		P(62-67)
29		21.10.2021		Natural frequency and unit step response.		T1 Ch3
30		22.10.2021		Introduction to Bode Plot, Gain Margin, Phase Margin.		P(67-86)
31	5	25.10.2021	Controllers	Introduction to controllers, Need for Control, Proportional (P), Integral (I) and Derivative (D) control actions.		T1 Ch3
32		28.10.2021		PI, PD and PID control systems in parallel form.		P(103-113)
33		29.10.2021		Numericals on PI, PD and PID control systems in parallel form		T1 Ch3
34		01.11.2021		Numericals on PI, PD and PID control systems in parallel form.		P(95-103)
35		04.11.2021		Feed forward anticipatory control.		T1 Ch3
36		05.11.2021		Manual tuning of PID control, Ziegler-Nichols method.		P(127-140)
37		08.11.2021		Applications: Electro-Hydraulic/Pneumatic Control, Automotive Control.		T1 Ch3
38	6	11.11.2021	Programmable Logic Controller (PLC)	Introduction to PLC- Architecture of PLC.		P(103-113)
39		12.11.2021		Selection of PLC.		T1 Ch3
40		15.11.2021		Ladder Logic programming for different types of logic gates.		P(95-103)
41		18.11.2021		Ladder Logic programming for different types of logic gates.		T1 Ch3
42		19.11.2021		Latching; Timers, Counters		P(127-140)
43		22.11.2021		PLC control of Hydraulics		P(48-51)
44		25.11.2021		PLC control of Pneumatics systems involving timing and counting operations		T1 Ch2
45		26.11.2021		PLC control of Mechatronics systems involving timing and counting operations		T1 Ch2

  
 Kunal Shriramprakash Marathe  
 Subject In-charge

**Mission:-**

- M1: Imparting Value Base Education
- M2: Integrating Engineering and Industry
- M3: Enhancing Employability and Entrepreneurship
- M4: Developing Research Culture

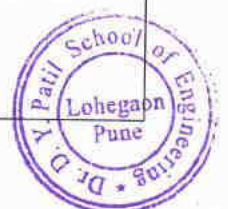

Dr. D. Y. Patil Technical Campus

# **Dr. D. Y. Patil School of Engineering**

Dr. D. Y. Patil Knowledge City, Charholi (Bk), Lohegaon, Pune – 412 105

## **11) Result Analysis**



1.1.1 - 11/11  
Dr. D. Y. Patil Technical Campus  
**Dr. D. Y. Patil School of Engineering**  
Dr. D. Y. Patil Knowledge City, Charholi (Bk), Lohegaon, Pune – 412 105  
Website: [www.dypic.in](http://www.dypic.in) Contact No.: 020-6707 7926

### RESULT ANALYSIS

**SPPU Examination: May 2020**  
**Department: Computer Engineering**

**Semester: 6**  
**Class: T.E (Credit)**

**Date of declaration of result: 06/01/2021**

#### A. Overall Result Analysis

Sr. No.	Details	No. of Students
1	No. of students appeared	144
2	No. of students passed (All clear)	141
3	No. of students failed	00
4	All clear passing Percentage	97.91%
5	All clear passing Percentage (University)	---
6	Percentage of passing with ATKT	2.08%
7	Percentage of passing with ATKT(University)	---
8	No. of students passed with Distinction	55
9	No. of students passed with First Class	66
10	No. of students passed with Higher Second Class	16
11	No. of students passed with Second Class	04
12	No. of students passed with Pass Class	---
13	No. of students failed in 1 Th. Sub	03
14	No. of students failed in 2 Th. Subs	---
15	No. of students failed in 3 Th. Subs	---
16	No. of students failed in more than 3 Th. Subs	---
17	No. of students failed in 1 Pr/Or	---
18	No. of students failed in 2 Pr/Or	---
19	No. of students failed in 3 Pr/Or	---

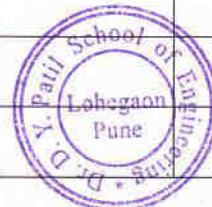

**B. Subject Wise Result Analysis:**

Sr.No.	Name of the Subject	TH/PR	Name of the Staff Member	No. of Students Appeared	No. of Students Passed	% of Passing
1	Design & Analysis of Algorithms	TH	Prof. Prashant Mandale	144	144	100
2	Systems Programming & Operating System (SP & OS)	TH	Prof. Pallavi Shimpi Prof. Niyamat Ujloomwale	144	142	98.61
3	Embedded Systems & Internet of Things (ES & IoT)	TH	Prof. Chaitanya Bhosale Prof. Yogesh Mali	144	143	99.30
4	Software Modeling and Design	TH	Prof. Ajita Mahapadi	144	144	100
5	Web Technology	TH	Prof. Ajit Pagar Prof. Swati Kadu	144	144	100
6	Seminar & Technical Communication	TW	Prof. Ajita Mahapadi	144	144	100
7	Web Technology Lab	PR TW	Prof. Ajit Pagar Prof. Swati Kadu	144	144	100
8	SP & OS Lab	PR TW	Prof. Pallavi Shimpi Prof. Niyamat Ujloomwale	144	144	100
9	ES & IoT Lab	TW	Prof. Chaitanya Bhosale Prof. Yogesh Mali	144	144	100



**C. Subject Wise Scoring Pattern:**

Sr. No.	Subject	No. of students appeared	No. of students obtaining marks in the range				Name of Topper	Marks Obtained
			66 to 100	60 to 65	55 to 59	54 to 40		
1	Design & Analysis of Algorithms	144	39	32	31	42	RITESH PATIDAR	87
2	Systems Programming & Operating System	144	35	28	28	51	DIVYA SATHE	84
3	Embedded Systems & Internet of Things	144	54	33	27	29	DIVYA SATHE	86
4	Software Modeling and Design	144	71	26	16	31	PATIL ABHISHEK YUVARAJ	88
5	Web Technology	144	24	23	35	62	DIXIT RITIN RANJAN PATIL ABHISHEK YUVARAJ	82



**D. Toppers:**

Rank	Examination Seat Number	Name of students	SGPA	Class Obtained
1	T150884227	DIVYA SATHE	9.26	First Class with Distinction
2	T150884237	GANGURDE TUSHAR CHANDRAKANT	9.09	First Class with Distinction
3	T150884338	SHREYAS VINAY TEMBHEKAR	9.00	First Class with Distinction
4	T150884224	DANGE MADHURI MURLIDHAR	8.91	First Class with Distinction
5	T150884235	GAIKWAD OMKAR DATTATRAY	8.83	First Class with Distinction
	T150884312	RITESH PATIDAR		
	T150884353	TAMBOLI TAUFIK SALIM		
	T150884564	KALE VAISHALI SUNIL		

Prepared By: Prof. Niyamat U., Prof. Chaitanya Bhosale  
Date- 31/01/2021



.....  
**Dr. Pankaj Agarkar**  
HOD



.....  
**Dr. Ashok Kasnale**  
Director



(11)

Dr. D. Y. Patil Technical Campus  
**Dr. D. Y. Patil School of Engineering**  
Dr. D. Y. Patil Knowledge City, Charholi (Bk), Lohegaon, Pune – 412 105  
Website: [www.dypic.in](http://www.dypic.in) Contact No.: 020-6707 7926  
Department of Mechanical Engineering  
Form No: IQAC/6 (a)

### RESULT ANALYSIS

**SPPU Examination: May 2021**

**Semester: II**

**Department: Mechanical Engineering**

**Class: SE (A and B & C)**

**Date of declaration of result: 23.08.2021**

#### A. Overall Result Analysis

Sr. No.	Details	No. of Students
1	No. of students appeared	153
2	No. of students passed(All clear)	127
3	No. of students failed	26
4	All clear passing Percentage	83.00%
5	All clear passing Percentage(University)	Not available
6	Percentage of passing with ATKT	100%
7	Percentage of passing with ATKT(University)	Not available
8	No. of students passed with Distinction	86
9	No. of students passed with First Class	37
10	No. of students passed with Higher Second Class	04
11	No. of students passed with Second Class	00
12	No. of students passed with Pass Class	00
13	No. of students failed in 1 Th. Sub	24
14	No. of students failed in 2 Th. Subs	00
15	No. of students failed in 3 Th. Subs	00
16	No. of students failed in more than 3 Th. Subs	00
17	No. of students failed in 1 Pr/Or	00
18	No. of students failed in 2 Pr/Or	00
19	No. of students failed in 3 Pr/Or	00





**B. Subject Wise Result Analysis:**

Sr. No.	Name of the Subject	TH/PR	Name of the Staff Member	No. of Students Appeared	No. of Students Passed	% of Passing
01	KOM 202047	TH A & B	Dr. Farook Sayyad	80	79	98.75%
		TH C	Prof. Prashant Karajgi	72	72	100%
02	ATD 202048	TH A & B	Prof. Rohit Garad	80	80	100%
		TH C	Dr. Imran Ansari	72	72	100%
03	FM 202049	TH A & B	Prof. Anil Bavche	79	79	100%
		TH C	Prof. Anil Bavche	72	71	98.61%
04	MP 202050	TH A & B	Prof. Amit Shinde	80	79	100%
		TH C	Prof. Amit Shinde	72	72	100%
05	EM III 207002	TH A & B	Prof. Bhagwat Gidhad	80	70	87.50%
		TH C	Prof. Bhagwat Gidhad	72	64	88.88%

**C. Subject Wise Scoring Pattern:**

Sr. No.	Subject	No. of students appeared	No. of students obtaining marks in the range				Name of Topper	Marks Obtained
			66 to 100	60 to 65	55 to 59	54 to 40		
1	KOM 202047	152	71	33	21	24	Sachin Kulkarni	94
2	ATD 202048	152	131	11	05	05	Total 03 students secured 99 Marks	99
3	FM 202049	151	139	06	03	02	Total 03 students secured 97 Marks	97
4	MP 202050	152	138	08	02	04	Total 05 students secured 100 Marks	100
5	EM III 207002	152	42	29	20	42	Kharpude Prajwal Sudam	96



**D.Toppers:**

Rank	Examination Seat Number	Name of students	SGPA	Class Obtained
01	S190880909	Ritik Chivate	9.66	First Class with Distinction
02	S190880899	Raghavendra Singh	9.41	First Class with Distinction
03	S190880914	Sachin Kulakarni	9.39	First Class with Distinction
04	S190880867	Kishor Anandrao Jadhav	9.34	First Class with Distinction
05	S190880947	Valase Atharv Sunil	9.23	First Class with Distinction



Prof. R. N. Garad  
HOD

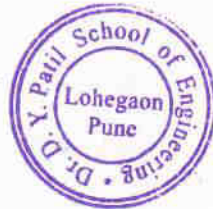

Dr. Farook Sayyad  
Principal

H. O. D.  
Dept. of Mechanical Engg.  
Dr. D. Y. Patil School of Engg., Lohegaon, Pune





(11)

Dr. D. Y. Patil Technical Campus  
**Dr. D. Y. Patil School of Engineering**  
Dr. D. Y. Patil Knowledge City, Charholi (Bk), Lohegaon, Pune – 412 105  
Website: [www.dypic.in](http://www.dypic.in) Contact No.: 020-6707 7926  
Department of Mechanical Engineering  
Form No: IQAC/6 (a)

### RESULT ANALYSIS

**SPPU Examination: May 2021**

**Semester: II**

**Department: Mechanical Engineering**

**Class: BE (2015 Pat.)**

**Date of declaration of result: 31 July 2021**

#### A. Overall Result Analysis

Sr. No.	Details	No. of Students
1	No. of students appeared	213
2	No. of students passed(All clear)	207
3	No. of students failed	06
4	All clear passing Percentage	97.64%
5	All clear passing Percentage(University)	Not available
6	Percentage of passing with ATKT	Not applicable
7	Percentage of passing with ATKT(University)	Not Available
8	No. of students passed with Distinction	207
9	No. of students passed with First Class	00
10	No. of students passed with Higher Second Class	00
11	No. of students passed with Second Class	00
12	No. of students passed with Pass Class	00
13	No. of students failed in 1 Th. Sub	01
14	No. of students failed in 2 Th. Subs	00
15	No. of students failed in 3 Th. Subs	00
16	No. of students failed in more than 3 Th, Subs	01
17	No. of students failed in 1 Pr/Or	00
18	No. of students failed in 2 Pr/Or	04
19	No. of students failed in 3 Pr/Or	01

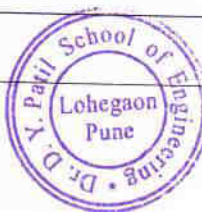

**B. Subject Wise Result Analysis:**

Sr. No.	Name of the Subject	TH/PR	Name of the Staff Member	No. of Students Appeared	No. of Students Passed	% of Passing	
01	EE	G	TH	Prof. Yogesh Gandal	73	73	100%
		H	TH	Prof. Yogesh Gandal	69	69	100%
		I	TH	Prof. Dipak Shelke	71	71	100%
02	MSD	G	TH	Prof. Vikram Ghule	73	73	100%
		H	TH	Prof. Paresh Khairnar	69	69	100%
		I	TH	Prof. Umaji Kolekar	71	70	98.59%
03	ELE III	IE	TH	Dr. Dileep More Dr. Imran Ansari Prof. Parag Marathe	213	213	100%
04	ELE IV	AMP	TH	Prof. Amol Patil Prof Pooja Nawathe Prof Pooja Nawathe	197	197	100%
		S&WE	TH	Self Studied	02	02	100%
		PDD	TH	Self Studied	14	14	100%



C. Subject Wise Scoring Pattern:

Sr. No.	Subject	No. of students appeared	No. of students obtaining marks in the range				Name of Topper	Marks Obtained
			66 to 100	60 to 65	55 to 59	54 to 40		
1	Energy Engg.	199	196	00	01	01	Total 116 students secured 100 Marks	100
2	Mechanical System Design	198	195	00	00	02	Total 76 students secured 100 Marks	100
3	402049B Industrial Engg.	198	197	00	00	01	Total 118 students secured 100 Marks	100
4	402050A Advanced Manufacturing Processes	183	177	00	04	02	Total 102 students secured 100 Marks	100
5	Solar & Wind Energy	02	02	00	00	00	Chakure Sourabh Shivaji	95
6	402050C Product Design And Development	14	14	00	00	00	Kasutubh K Dhawale	97

D. Toppers:

Rank	Examination Seat Number	Name of students	SGPA	Class Obtained
01	--	Total 04 students have secured	10.00	First class with Distinction
02	--	Total 05 students have secured	9.98	First class with Distinction
03	--	Total 05 students have secured	9.95	First class with Distinction
04	--	Total 15 students have secured	9.93	First class with Distinction
05	--	Total 12 students have secured	9.91	First class with Distinction

Prof. R. N. Garad  
HOD

H. O. D.

Dept. of Mechanical Engg.



Dr. F.B. Sayyad  
Principal



11

Dr. D. Y. Patil Technical Campus  
**Dr. D. Y. Patil School of Engineering**  
Dr. D. Y. Patil Knowledge City, Charholi (Bk), Lohegaon, Pune – 412 105  
Website: [www.dypic.in](http://www.dypic.in) Contact No.: 020-6707 7926  
Department of Mechanical Engineering  
Form No: IQAC/7

**RESULT ANALYSIS**

SPPU Examination: May 2021

Semester: II

Department: Mechanical Engineering

Class: TE (D,E and F)

Date of declaration of result: 03.08.2021

**A. Overall Result Analysis**

Sr. No.	Details	No. of Students		
		Credit	Percentage	Combined
1	No. of students appeared	217	01	218
2	No. of students passed(All clear)	192	01	193
3	No. of students failed	25	00	25
4	All clear passing Percentage	88.47%	100%	88.53%
5	All clear passing Percentage(University)	Not available	Not available	Not available
6	Percentage of passing with ATKT	99.53%	100%	99.54%
7	Percentage of passing with ATKT(University)	Not available	Not available	Not available
8	No. of students passed with Distinction	192	01	193
9	No. of students passed with First Class	00	00	00
10	No. of students passed with Higher Second Class	00	00	00
11	No. of students passed with Second Class	00	00	00
12	No. of students passed with Pass Class	00	00	00
13	No. of students failed in 1 Th. Sub	03	00	03
14	No. of students failed in 2 Th. Subs	00	00	00
15	No. of students failed in 3 Th. Subs	00	00	00
16	No. of students failed in more than 3 Th. Subs	00	00	00
17	No. of students failed in 1 Pr/Or	11	00	11
18	No. of students failed in 2 Pr/Or	05	00	05



19	No. of students failed in 3 Pr/Or	03	00	03
----	-----------------------------------	----	----	----

**B. Subject Wise Result Analysis:**

Sr. No.	Name of the Subject	TH/PR	Name of the Staff Member	No of students Appeared	No of students passed	% of Passing
01	NMO 302047	D	Prof. Sandip Bhaskar	73	73	100
		E	Prof. Nitin More	72	72	100
		F	Prof. Nitin More	71	71	100
02	DME II 302048	D	Prof. Yogesh Danekar	73	73	100
		E	Prof. Prashant Karajagi	72	72	100
		F	Prof. Vinod Patil	71	71	100
03	RAC 302049	D	Prof. Kundan Kolambe	73	73	100
		E	Prof. Kundan Kolambe	72	71	98.61
		F	Prof. Dipak Shelke	71	71	100
04	MCTX 302050	D	Prof. Kunal Marathe	73	73	100
		E	Prof. Sachin Jadhav	71	71	100
		F	Prof. Sachin Jadhav	71	71	100
05	MP II 302051	D	Prof. Tejswini Kulkarni	73	73	100
		E	Prof. Tejswini Kulkarni	72	72	100
		F	Prof. Amol Gaikwad	71	71	100

**C. Subject Wise Scoring Pattern:**



Sr. No.	Subject	No. of students appeared	No. of students obtaining marks in the range				Name of Topper	Marks Obtained
			66 to 100	60 to 65	55 to 59	54 to 40		
1	NMO	217	212	02	02	01	Total 03 no of students secured 94 Marks	94
2	DME II	217	216	01	00	00	Total 41 no of students secured 100 Marks	100
3	RAC	214	212	01	01	00	Total 120 no of students secured 100 Marks	100

4	MCTX	215	213	02	00	01	Total 17 no of students secured 100 Marks	100
5	MP II	217	215	02	00	00	Total 82 no of students secured 100 Marks	100

**D.Toppers:**

Rank	Examination Seat Number	Name of students	SGPA	Class Obtained
1	T150880902	Karandeep Singh Bagga	9.98	First Class With Distinction
2	T150880806	Anurag Krishnan Namboodiri	9.96	First Class With Distinction
3	--	Total 03 students secured SGPA of 9.93	9.93	First Class With Distinction
4	--	Total 02 students secured SGPA of 9.91	9.91	First Class With Distinction
5	--	Total 05 students secured SGPA of 9.89	9.89	First Class With Distinction

Prof. R. N. Garad  
HOD



Dr. Farook Sayyad  
Principal

H. O. D.  
Dept. of Mechanical Engg.





Dr. D. Y. Patil Technical Campus  
**Dr. D. Y. Patil School of Engineering**  
 Dr. D. Y. Patil Knowledge City, Charholi (Bk), Lohegaon, Pune - 412 105  
 Website: [www.dypic.in](http://www.dypic.in) Contact No.: 020-6707 7926  
 Department of First Year Engineering  
 Form No: IQAC/7



### RESULT ANALYSIS

Semester: I  
 Class: FE (A, B, C, D)

Unit Test-1 : March'2021  
 Department: First Year Engineering

#### Subject Wise Result Analysis:

Sr. No.	Name of the Subject	Div	Name of the Subject Teacher	Total Students	No of students Present	No of students Absent	No of students Passed	No of students Failed	Passing Percentage	Sign of Subject Teacher
01	M-I	A	Dr. Rahul Kumar Katkade	70	69	1	65	4	94.20	
		B		70	62	8	61	1	98.38	
		C		70	64	6	59	5	92.18	
		D		70	64	6	62	2	96.87	
02	SME	A	Mr. Awes Ansari	70	67	3	66	1	98.50	
		B		70	66	4	66	0	100	
		C		70	66	4	65	1	98.48	
		D		70	63	7	63	0	100	



03	BEE	A	Ms. Rohini Gadgil	70	65	5	65	0	100
		B	Mr. Tejpal Pardeshi	70	66	4	63	3	95.45
04	BXE	C	Ms. Sayali mane	70	67	3	66	1	98.50
		D		70	64	6	62	2	96.87
05	PPS	A	Mr. Prashant Sagare	70	67	3	67	0	100
		B		70	63	7	61	2	96.82
06	EM	C	Mr. Prasad Gayake	70	69	1	67	2	97.10
		D		70	66	4	65	1	98.48
07	EC	C	Dr. Shobha Rupnar	70	69	1	67	2	97.10
		D		70	64	6	62	2	96.87
08	EP	A	Ms. Soma Cyriac	70	44	26	44	0	100
		B		70	44	26	43	1	97.72

Note: Physics Test of Div. A & B was conducted by Mr. Amit Uphad.

  
Dr. S.M. Khairnar  
HOD



  
Dr. Ashok Kasnale  
Principal



Dr. D. Y. Patil Technical Campus  
**Dr. D. Y. Patil School of Engineering**  
Dr. D. Y. Patil Knowledge City, Charholi (Bk), Lohegaon, Pune - 412  
105  
Website: [www.dypic.in](http://www.dypic.in) Contact No.: 020-6707 7926

### RESULT ANALYSIS

SPPU Examination: APR/MAY 2021

Semester: 8

Department: Computer Engineering

Class: B.E(Percentage)

Date of declaration of result: 31/07/2021

#### A. Overall Result Analysis

Sr. No.	Details	No. of Students
1	No. of students appeared	6
2	No. of students passed (All clear)	6
3	No. of students failed	--
4	All clear passing Percentage	100%
5	All clear passing Percentage (University)	---
6	Percentage of passing with ATKT	---
7	Percentage of passing with ATKT(University)	---
8	No. of students passed with Distinction	6
9	No. of students passed with First Class	---
10	No. of students passed with Higher Second Class	---
11	No. of students passed with Second Class	---
12	No. of students passed with Pass Class	---
13	No. of students failed in 1 Th. Sub	---
14	No. of students failed in 2 Th. Subs	---
15	No. of students failed in 3 Th. Subs	---
16	No. of students failed in more than 3 Th. Subs	---
17	No. of students failed in 1 Pr/Or	---
18	No. of students failed in 2 Pr/Or	---
19	No. of students failed in 3 Pr/Or	---

**B. Subject Wise Result Analysis:**

Sr.No.	Name of the Subject	TH/PR	Name of the Staff Member	No. of Students Appeared	No. of Students Passed	% of Passing
1	MACHINE LEARNING	TH	Prof. Sunil Rathod Prof. Jayashree Chaudhari	6	6	100
2	INFORMATION AND CYBER SECURITY	TH	Prof. Ashwini Pandagale	6	6	100
3	SOFT COMPU. & OPTIM. ALGO.	TH	Prof.Pallavi Shimpi	6	6	100
4	CLOUD COMPUTING	TH	Prof.Pankaj Agarkar Prof.Yogesh Mali	6	6	100
5	LABORATORY PRACTICE III	PR TW	Prof. Sunil Rathod Prof. Jayashree Chaudhari	6	6	100
6	LABORATORY PRACTICE IV	OR TW	Prof.Pallavi Shimpi Prof.Yogesh Mali	166	166	100
7	PROJECT WORK STAGE II	PR TW	All Faculties	166	166	100

C. Subject Wise Scoring Pattern:

Sr.No.	Subject	No. of students appeared	No. of students obtaining marks in the range				Name of Topper	Marks obtained
			66 to 100	60 to 65	55 to 59	40 to 54		
1	MACHINE LEARNING	6	5	-	1	-	VISHAL KUMAR SINGH	99
2	INFORMATION AND CYBER SECURITY	6	6	-	-	-	DHUMAL MAHESH	94
3	SOFT COMPU. & OPTIM. ALGO.	6	6	3	3	7	MORE SNEHAL SHASHIKANT	96
4	CLOUD COMPUTING	6	6	3	-	-	MORE SNEHAL SHASHIKANT	96

*Pallavi*

Prepared By: Prof. Pallavi Shimpi  
Date- 10/08/2021

.....  
Dr. Pankaj Agarkar  
HOD



..... F3  
Dr. F.B. Sayyad  
Principal



Dr. D. Y. Patil Technical Campus  
**Dr. D. Y. Patil School of Engineering**  
Dr. D. Y. Patil Knowledge City, Charholi (Bk), Lohegaon, Pune - 412  
105  
Website: [www.dypic.in](http://www.dypic.in) Contact No.:020-6707 7926

### RESULT ANALYSIS

SPPU Examination: APR/MAY 2021

Semester: 8

Department: Computer Engineering

Class: B.E(Credit)

Date of declaration of result: 31/07/2021

#### A. Overall Result Analysis

Sr. No.	Details	No. of Students
1	No. of students appeared	166
2	No. of students passed (All clear)	165
3	No. of students failed	01
4	All clear passing Percentage	99.4%
5	All clear passing Percentage (University)	---
6	Percentage of passing with ATKT	0.6%
7	Percentage of passing with ATKT(University)	---
8	No. of students passed with Distinction	70
9	No. of students passed with First Class	90
10	No. of students passed with Higher Second Class	05
11	No. of students passed with Second Class	---
12	No. of students passed with Pass Class	---
13	No. of students failed in 1 Th. Sub	---
14	No. of students failed in 2 Th. Subs	---
15	No. of students failed in 3 Th. Subs	---
16	No. of students failed in more than 3 Th. Subs	---
17	No. of students failed in 1 Pr/Or	---
18	No. of students failed in 2 Pr/Or	---
19	No. of students failed in 3 Pr/Or	---

**B. Subject Wise Result Analysis:**

Sr.No.	Name of the Subject	TH/PR	Name of the Staff Member	No. of Students Appeared	No. of Students Passed	% of Passing
1	MACHINE LEARNING	TH	Prof. Sunil Rathod Prof. Jayashree Chaudhari	166	166	100
2	INFORMATION AND CYBER SECURITY	TH	Prof. Ashwini Pandagale	166	166	100
3	SOFT COMPU. & OPTIM. ALGO.	TH	Prof.Pallavi Shimpi	164	164	100
4	CLOUD COMPUTING	TH	Prof.Pankaj Agarkar Prof.Yogesh Mali	164	164	100
5	LABORATORY PRACTICE III	PR TW	Prof. Sunil Rathod Prof. Jayashree Chaudhari	166	166	100
6	LABORATORY PRACTICE IV	OR TW	Prof.Pallavi Shimpi Prof.Yogesh Mali	166	166	100
7	PROJECT WORK STAGE II	PR TW	All Faculties	166	166	100

C. Subject Wise Scoring Pattern:

Sr.No.	Subject	No. of students appeared	No. of students obtaining marks in the range				Name of Topper	Marks obtained
			66 to 100	60 to 65	55 to 59	40 to 54		
1	MACHINE LEARNING	166	141	13	7	5	CHINDARKAR REETEJ	100
2	INFORMATION AND CYBER SECURITY	166	166	-	-	-	ABHISHEK KUMAR JAISWAL	100
3	SOFT COMPU. & OPTIM. ALGO.	164	151	3	3	7	ANDHARE PRACHI	100
4	CLOUD COMPUTING	164	161	3	-	-	BADHE MAHESH RAJARAM	100

D. Toppers:

Rank	Examination Seat Number	Name of students	CGPA	Class Obtained
1	B150884225	DIVYA SATHE	8.96	First Class with Distinction
5	B150884313	RITESH PATIDAR	8.9	First Class with Distinction
2	B150884297	PATIL RUTUJA RAMESH	8.7	First Class with Distinction
3	B150884233	GAIKWAD OMKAR DATTATRAY	8.66	First Class with Distinction
4	B150884290	PARMAR SANJAY NARESH	8.64	First Class with Distinction

*Pallavi*

Prepared By: Prof. Pallavi Shimpi  
Date- 10/08/2021

*Pankaj*  
Dr. Pankaj Agarkar  
HOD



*F.B.*  
Dr. F.B. Sayyad  
Principal





Dr. D. Y. Patil Technical Campus  
**Dr. D. Y. Patil School of Engineering**  
Dr. D. Y. Patil Knowledge City, Charholi (Bk), Lohegaon, Pune - 412  
105  
Website: [www.dypic.in](http://www.dypic.in) Contact No.: 020-6707 7926

### RESULT ANALYSIS

SPPU Examination: Dec 2020  
Department: Computer Engineering

Semester: 7  
Class: B.E(Credit)

Date of declaration of result: 12/07/2021

#### A. Overall Result Analysis

Sr. No.	Details	No. of Students
1	No. of students appeared	165
2	No. of students passed (All clear)	165
3	No. of students failed	00
4	All clear passing Percentage	100.00%
5	All clear passing Percentage (University)	---
6	Percentage of passing with ATKT	0.00%
7	Percentage of passing with ATKT(University)	---
8	No. of students passed with Distinction	165
9	No. of students passed with First Class	---
10	No. of students passed with Higher Second Class	---
11	No. of students passed with Second Class	---
12	No. of students passed with Pass Class	---
13	No. of students failed in 1 Th. Sub	---
14	No. of students failed in 2 Th. Subs	---
15	No. of students failed in 3 Th. Subs	---
16	No. of students failed in more than 3 Th. Subs	---
17	No. of students failed in 1 Pr/Or	---
18	No. of students failed in 2 Pr/Or	---

19	No. of students failed in 3 Pr/Or	---
----	-----------------------------------	-----

**B. Subject Wise Result Analysis:**

Sr.No.	Name of the Subject	TH/PR	Name of the Staff Member	No. of Students Appeared	No. of Students Passed	% of Passing
1	HIGH PERFORMANCE COMPUTING	TH	Mr. Pankaj Agarkar Mr. Yogesh Mali	165	165	100
2	ARTIFICIAL INTEL. & ROBOTICS	TH	Dr. Sunil Rathod	165	165	100
3	DATA ANALYTICS	TH	Ms. Niyamat U.	165	165	100
4	DATA MINING AND WAREHOUSING	TH	Prof. Jayashree Chaudhari	165	165	100
5	SW. TESTING & QA.	TH	Ms. Pallavi Shimpi	165	165	100
6	LABORATORY PRACTICE I	TW	Mr. Pankaj Agarkar Mr. Yogesh Mali	165	165	100
7	LABORATORY PRACTICE II	PR TW	Prof. Jayashree Chaudhari Ms. Pallavi Shimpi	165	165	100
8	PROJECT WORK STAGE I	PR TW	Prof. Monika Dangore	165	165	100

**C. Subject Wise Scoring Pattern:**

Sr. No.	Subject	No. of students appeared	No. of students obtaining marks in the range				Name of Topper	Marks Obtained
			66 to 100	60 to 65	55 to 59	54 to 40		
1	HIGH PERFORMANCE COMPUTING	165	136	7	2	1	SALONI DANGRE	100
2	ARTIFICIAL INTEL. & ROBOTICS	165	155	7	2	1	GHADLING CHAITANYA	100

3	DATA ANALYTICS	165	155	6	4	--	GANATRA DARSHAN	100
4	DATA MINING AND WAREHOUSING	165	163	1	--	1	ABHISHEK KUMAR JAISWAL	100
5	SW. TESTING & QA.	165	159	4	2	--	SWATI BALYAN	100

**D. Toppers:**

Rank	Seat Number	Name of students	SGPA	Class Obtained
1	B150884209	BADHE MAHESH RAJARAM	10	First Class with Distinction
2	B150884223	DEO ADITYA ANANT	10	First Class with Distinction
3	B150884225	DIVYA SATHE	10	First Class with Distinction
4	B150884267	KULKARNI MAYURESH	10	First Class with Distinction
5	B150884275	MHASKE SAYALI	10	First Class with Distinction

Prepared By: Prof. Pallavi Shimpi  
Prof. Komal Jakotiya

Date- 14/07/2021

.....  
Dr. Pankaj Agarkar  
HOD



.....  
Dr. F.B. Sayyad  
Principal

Dr. D. Y. Patil Technical Campus

# **Dr. D. Y. Patil School of Engineering**

Dr. D. Y. Patil Knowledge City, Charholi (Bk), Lohegaon, Pune – 412 105

13) Bridge Courses - Content,  
Schedule, Attendance, Material,  
Feedback, Feedback Analysis.



Event Report

Academic Year: 2020-21

Semester-I

1. Name of the event: Seminar on "Application of Strength of Materials in Automotive Sector"

Date and Time	15 <sup>th</sup> April 2021 & 12:00 pm to 02.00 pm
Event Venue	Microsoft Teams
Organized by	Mechanical Engineering Department
Audience	76 (S.E. Students)
Resource Person	Mr. Vishal Bhat

2. Event Contents:

1. Introduction to Modern technology in Automotive Sector
2. Why use it
3. Conceptualization
4. Marketing
5. Advantages and Application

3.1 Details of the event:

A Workshop on "Application of Strength of Materials in Automotive Sector" is organized on 15<sup>th</sup> April 2021 for Second Year students of Department of Mechanical Engineering, Dr D Y Patil School of Engineering, Lohegaon, Pune. The presentation will be conducted by Mr. Vishal Bhat, presently associated with John Deere Ltd., Pune. His valuable suggestions and guidance is useful for students to achieve their correct objective in future.

3.2 Introduction to Modern technology in Automotive Sector

In modern trend of increasing more power and torque demand from smaller vehicle, many engine manufacturers are moving towards developing new concepts in engine design. The requirement not only includes low weight and high strength material, but also



design techniques and manufacturing methodology. The seminar includes all the modern trend and concepts used in new generation engine design

Applications

- Reduce Development Costs
  - Cut traditional prototyping and tooling costs.
  - Identify design errors earlier.
  - Reduce travel to production facilities.

Event Photos: Seminar on "Application of Strength of Materials in Automotive Sector"

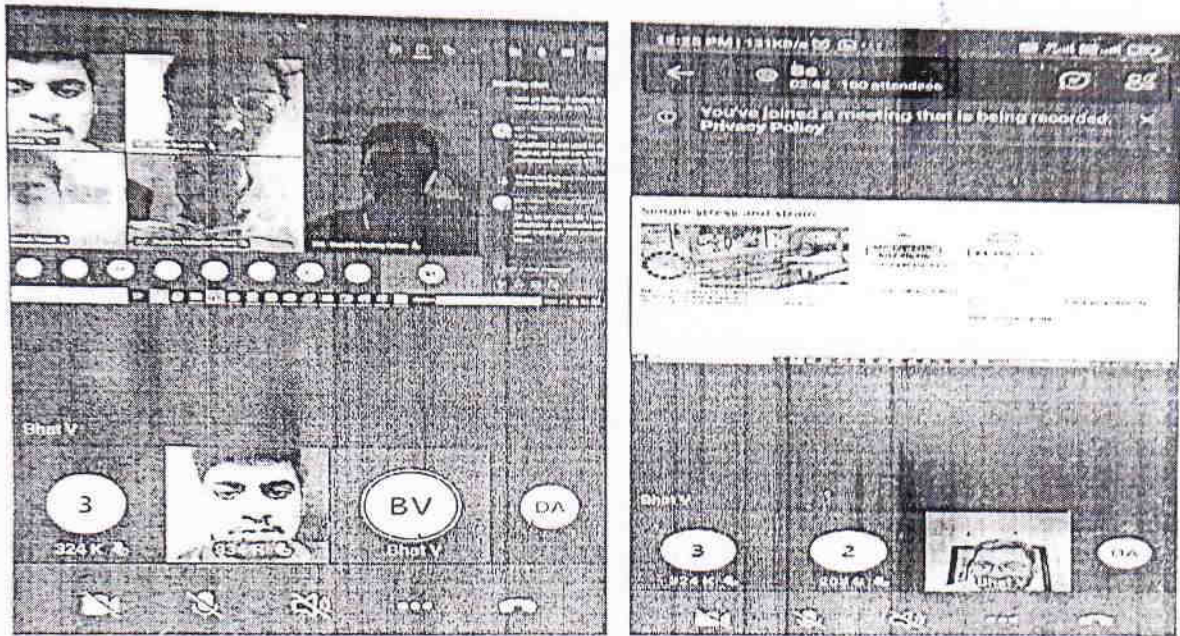

We are extremely thankful to Hon. Principal Dr. Ashok Kasnale of D.Y. Patil, SoE, Lohegaon, Pune. We would like to specially thank to our HoD Prof. R. N. Garad; all staff & student coordinators' for providing a full-fledged support in all aspects during the entire expert lecture.

We thankful to Dr F B Sayyad (Dean Acad.), and Mr. Moreshwyer Kundap (Staff), has supported and guided us to make this lecture successful.

Enclosed with

- Student Attendance

Dr. M. L. Ansari  
Faculty-Coordinator



Prof. R. N. Garad  
HoD (Mech. Department)

H. O. D.  
Dept. of Mechanical Engg.  
Dr. D. Y. Patil School of Engg., Lohegaon, Pune

- 71 Sonali More  
16 Hussain Rangwala  
63 Dakshit Mahadeshwar  
65 Nishid Walde  
29 Mansi Kulkarni  
29 Soham Rahul Kamthe  
25 Kalpana kumari  
18 Rutuja thokale  
26 Kalyani Sunil Chopade  
72 Aniket Wagh  
25 KSHITIZ KUMAR  
15 Snehal Vaman Karale  
50 Pushkar Rahane  
49 Nupur Shah  
04 Shaikh Azim Abdul Rahim  
56 Kajal Sanjay Jagtap  
03 Allaudin Shaikh  
70 Bhagyshree Siddaram Muddadagi  
68 Anandkumar Rai  
55 Shraddha Karande  
52 Prachi tekade  
33 Yash Kumbhar  
45 Shaikh Ashraf Mukhtar  
47 Abhijeet pitlewad  
23 Dattaram Kajrekar



- 36 Faisal Momin  
43 Aishwarya Ramesh Patil  
40 Nazia  
2 Anirudh Sanjay Mhaske  
32 Swaraj Ashok Kokate  
33 Rushikesh Baban Lokhande  
11 Siddharth Raghuvanshi  
28 Shweta Ramesh Naikawadi  
48 Pratima Gaikwad  
61 Ajit chouhan  
53 Kunal Chavare  
55 Sayyed Zoha Sameer  
35 Sahil Sudhir Pawar  
34 Nitin Mishra  
50 Ganesh tak  
17 Abhishek C Jadhav  
66 Advait Bhujbal  
16 Sumant Sankurwar  
56 Sakshi Barve  
46 Pravin Payghan  
42 Abhinav Jagtap  
07 Kaustubh manoj chaudhari  
30 Riya Rahul Lunkad  
24 Mrityunjay Mishra  
21 Varun Shashikant Patil





- 37 Satyam Premnath Dube  
5 Shaizan Khan  
22 Jyoti Prakash Singh  
17 Tejas Bafna  
1 Priyanka Sagar  
36 Gauri Sureshrao Gotmare  
8 Shradha Umesh Dhore  
31 Khambhayta Ajaykumar Rashminbhai  
11 Karan Gadale  
57 Snehal Ajay Pol  
45 Pawar Mansi Sanjay  
53 Sandesh Sunil Khore  
38 Namrata Mahendra Harke  
9 Devaksh Bhagat  
37 SOHAIL S. MUJAWAR  
28 Manoj Kakasaheb Kamthe  
10 Fiza Azam  
54 shubham sarode  
41 Yash Vijay Nimbalkar  
27 Mohammad Rafe  
67 Veenish Mourya  
44 Pawar Bhavesh Hemant  
49 Pushkar Mahajan  
5 Chandani Kumari  
38 Adarsh Sunil Maskar

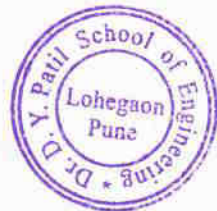

**Dr. D. Y. Patil Technical Campus**

# **Dr. D. Y. Patil School of Engineering**

Dr. D. Y. Patil Knowledge City, Charholi (Bk), Lohegaon, Pune – 412 105

**14) Departmental Peer Assessment Of  
Teaching And Its Analysis From  
External Peers.**

Dr. D. Y. Patil Technical Campus

# **Dr. D. Y. Patil School of Engineering**

Dr. D. Y. Patil Knowledge City, Charholi (Bk), Lohegaon, Pune – 412 105

Due to The Pandemic situation this activity  
was not possible.

Dr. D. Y. Patil Technical Campus

# **Dr. D. Y. Patil School of Engineering**

Dr. D. Y. Patil Knowledge City, Charholi (Bk), Lohegaon, Pune – 412 105

15) Departmental Swoc- External &&  
Internal



**DR. D. Y. PATIL SCHOOL OF ENGINEERING**

Dr. D. Y. Patil Knowledge City, Charholi (Bk), Lohgaon, Pune – 412 105

**DEPARTMENT OF CIVIL ENGINEERING**

**SWOC**

**Strength:**

- 1. Adequate physical infrastructure exists
- 2. Committed management
- 3. Locational advantages being in city of Pune
- 4. Committed and dedicated faculty and staff
- 5. Strong administrative support to academic, cultural programs and student services
- 6. Attractive urban campus with well-equipped laboratories and physical infrastructure
- 7. Remedial classes organized for academically weak student

**Weakness**

- 1. Less number of students from out of state
- 2. College has not attracted externally funded research projects
- 3. **Lack of consultancy work.**
- 4. Research culture is missing in the college
- 5. A few faculties with Ph.D qualifications
- 6. Quality of publications is less and poor

**Opportunities**

- 1. Dr. D Y Patil brand name to be utilized effectively for marketing & communication
- 2. Resource generation through research and consultancy
- 3. Attracting funded projects
- 4. Skill development programs for teaching and non-teaching staff progression
- 5. Make DYP SOE technical Institution synergizing between all stake holders

**Challenges**

- 1. Availability of qualified faculty

2. High cost of delivering program
3. Regular investment to keep pace with emerging technologies
4. Competing with other technical institutions under SPPU university
5. Campus placements of all students with good packages

**HOD**

**PROF. S. M KARODPATI**

H.O.D.   
Department of Civil Engineering  
Dr. D. Y. Patil School of Engg. Lohegaon



Dr. D. Y. Patil Technical Campus

# **Dr. D. Y. Patil School of Engineering**

Dr. D. Y. Patil Knowledge City, Charholi (Bk), Lohegaon, Pune – 412 105

19) One Page Of Student Information  
And Its Analysis.



Dr. D. Y. Patil Group of Institutions Technical Campus  
**Dr. D. Y. PATIL SCHOOL OF ENGINEERING**  
Dr. D. Y. Patil Knowledge City, Charholi Bk., Via. Lohegaon, Pune 412 105.  
Department of Civil Engineering

Form No. IQAC/11

Student' s Mentoring Book

Date: / /

/20\_\_

**A) List of Student**

Academic Year: 2020-21 Semester-I/II

Class: S.E

Division: B

Batch: \_\_\_\_\_

Roll No.	Name of Student	Information of Student		Information of Parent	
		Mobile Number	Email ID	Mobile Number	Address for correspondence
80	Meenakshi Bajarang shendage	7219106501	meenakshishendage91@gmail.com	7219106501	A/P Mandve Tal malshiras Dis solapur

Name and Sign of Mentor: Shree Bajarang Shendage

**B) Information of Parents**

Roll No.	Name of Parent	Email ID	Job Details		
			Employed / Self Employed	Name of Organization	Designation
	Bajarang shendage	shendagebn@gmail.com	Employee	Samaj jagruti seva Sangh morochi Ashram school	Teacher

  
Class Teacher  
Prof. Uzma sheikh

HOD  
Prof. S M Karodpali

H.O.D.  1

Department of Civil Engineering  
Dr. D. Y. Patil School of Engg. Lohegaon

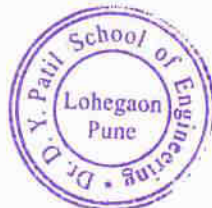





## STUDENT INFORMATION SHEET

1. Name of Student : Priyanka Bhagwan Chaudhari
2. Department : Mechanical Engineering
3. D. O. Birth : 10 sep 1997
4. Email ID : [priyankachaudhari361@gmail.com](mailto:priyankachaudhari361@gmail.com)
5. Mobile no. : 8796709143/8485019143

Qualification	Division	%	Year of Passing
DSE :	D	6.65	2020
TE :	D	8.8	2021
BE :	H	-	-
Other :			

6. Awards :- NA



Dr. D. Y. Patil Technical Campus

# **Dr. D. Y. Patil School of Engineering**

Dr. D. Y. Patil Knowledge City, Charholi (Bk), Lohegaon, Pune – 412 105

## 16) Student Feedback On Departmental Functioning

Dr. D. Y. Patil Technical Campus  
**Dr. D. Y. PATIL SCHOOL OF ENGINEERING**  
 Dr. D. Y. Patil Knowledge City, Charoli Bk., Via. Lohegaon, Pune – 412 105.  
 Department of Mechanical Engineering  
**VISION: EMPOWERMENT THROUGH ACADEMIC EXCELLENCE**

**Feedback Summary**

AY: 2020/21

Sem: II

Sr. No.	Name of Faculty	Class and Division	Subject	Feedback
1	Dr F. B Sayyed	SE Mechanical (Div A+B)	KOM	90
2	Prof. R. N. Garad	SE Mechanical (Div A+B)	ATD	85.6
3	Prof. Ansari M.	SE Mechanical (Div C)	ATD	79.8
		BE Mechanical (Div C)	IE	85
4	Prof. K. S. Marathe	TE Mechanical (Div D)	MTX	83.4
5	Prof. S. B. Jadhav	TE Mechanical (Div E)	DME - II	85.6
6	Prof. D. D. Shelke	TE Mechanical (Div F)	RAC	80.6
		BE Mechanical (Div I)	EE	85.4
7	Prof. P. P. Khairnar	BE Mechanical (Div H)	MSD	86
8	Prof. V. M. Ghule	BE Mechanical (Div G)	MSD	86
9	Prof. A. B. Gaikwad	TE Mechanical (Div F)	MP II	78
10	Prof. V. G. Patil	TE Mechanical (Div F)	DME - II	81.8
11	Prof. A. N. Patil	BE Mechanical (Div G)	AMP	89.4
12	Dr. D. S. More	BE Mechanical (Div G)	IE	88
13	Prof. S. Bhaskar	TE Mechanical (Div D)	NMO	78
14	Prof. Y. S. Gandal	BE Mechanical (Div G H)	EE	88.4
15	Prof. Y. S. Danekar	TE Mechanical (Div D)	DME - II	81.6
16	Prof. S. S. Jadhav	TE Mechanical (Div E F)	MTX	81.8
17	Prof. K. Kolambe	TE Mechanical (Div D E)	RAC	81
18	Prof. U. N. Kolekar	BE Mechanical (Div I)	MSD	85
19	Prof. N. N. More	TE Mechanical (Div E F)	NMO	80.4
20	Prof. P. G. Karajagi	TE Mechanical (Div C)	KOM	81.4
21	Prof. P. R. Nawathe	BE Mechanical (Div H I)	AMP	86
22	Prof. T. S. Kulkarni	SE Mechanical (Div D E)	MP II	81.6
23	Prof. B. Gidhad	SE Mechanical (Div A+B, C)	M III	80.4
24	Prof. P. B. Marathe	BE Mechanical (Div I)	IE	88.4
25	Prof. A. A. Shinde	SE Mechanical (Div A+B, C)	MP	82.4
26	Prof. A. Bavche	SE Mechanical (Div A+B, C)	FM	78.4

Department Coordinator

HoD (Mechanical Department)



H. O. D.

Dent. of Mechanical Engg.

Dr. D. Y. Patil Technical Campus  
**Dr. D. Y. PATIL SCHOOL OF ENGINEERING**  
Dr. D. Y. Patil Knowledge City, Charoli Bk., Via. Lohegaon, Pune – 412 105.  
Department of Civil Engineering

**VISION: EMPOWERMENT THROUGH ACADEMIC EXCELLENCE**

**Feedback Summary**

AY: 2020/21

Sem: II

Turn I

Sr. No.	Name of Faculty	Class and Division	Subject	% Feedback
1	Ms. Akansha A Ingle	SE Civill (Div A )	BTAP	82.94
2	Mr. Bhagwat Gidadh	SE Civill (Div A )	M III	77.08
3	Ms. Pragya Sharma	SE Civill (Div A )	EG	76.72
4	Mr. Aniket V. Nemade	SE Civill (Div A )	MOS	92.53
5	Ms. Uzma Shaikh	SE Civill (Div A )	FM I	80.73
6	Mr. Uday A. Kakde	TE Civil (Div B)	SD II	78.03
7	Mr. Rajesh C. Katdare	TE Civil (Div B)	ENV. I	77.02
8	Ms. Pragya Sharma	TE Civil (Div B)	FE	76.04
9	Ms. Akansha A Ingle	TE Civil (Div B)	PMEE	77.07
10	Mr. S. M. Karodpati	TE Civil (Div B)	ADS	80.17
11	Ms Pragya Sharma	BE Civil (Div C)	APC	82.87
12	Ms. Akansha A Ingle	BE Civil (Div C)	CM	83.08
13	Mr. Ramakant D. Koshti	BE Civil (Div C)	QSCT	86.31
14	Ms. Uzma Shaikh	BE Civil (Div C)	DHS	84.78

  
Department Coordinator

HoD (Civil Department)

H.O.D. 

Department of Civil Engineering  
Dr. D. Y. Patil School of Engg. Lohegaon

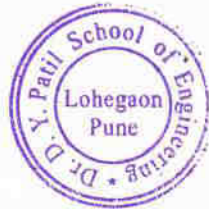

Dr. D. Y. Patil Technical Campus

# **Dr. D. Y. Patil School of Engineering**

Dr. D. Y. Patil Knowledge City, Charholi (Bk), Lohegaon, Pune – 412 105

18) Annual Departmental Calendar



Dr. D. Y. Patil Educational Enterprises Charitable Trust's  
**Dr. D. Y. PATIL SCHOOL OF ENGINEERING**  
 Dr. D. Y. Patil Knowledge City, Charholi (Bk.), Via. Lohegaon, Pune - 412 105

**Academic Calender**

**Term I**

**Academic Year 2020-21**

JULY			AUGUST			SEPTEMBER			OCTOBER			NOVEMBER			DECEMBER			
Date	Day	Activity	Date	Day	Activity	Date	Day	Activity	Date	Day	Activity	Date	Day	Activity	Date	Day	Activity	
1	Wed		1	Sat	Bakri Idd	1	Tues	Annat Chaturdashi	1	Thur		1	Sun		1	Tues		
2	Thur		2	Sun		2	Wed		2	Fri	Mahatma Gandhi Jayanti	2	Mon		2	Wed		
3	Fri		3	Mon	Rakshabandhan	3	Thur		3	Sat		3	Tues		3	Thur		
4	Sat		4	Tues		4	Fri		4	Sun		4	Wed		4	Fri		
5	Sun		5	Wed		5	Sat		5	Mon		5	Thur		5	Sat		
6	Mon		6	Thur		6	Sun		6	Tues	Project Stage Activity- II	6	Fri		6	Sun		
7	Tues		7	Fri		7	Mon		7	Wed		7	Sat	Unit Test III	7	Mon		
8	Wed		8	Sat		8	Tues		8	Thur		8	Sun		Project Stage Activity- III	8	Tues	
9	Thur		9	Sun		9	Wed		9	Fri	APR II	9	Mon			UG Term End as per SPPU	9	Wed
10	Fri		10	Mon		10	Thur		10	Sat		10	Tues	Diwali			10	Thur
11	Sat		11	Tues		11	Fri		11	Sun		11	Wed		SPPU UG-POE		11	Fri
12	Sun		12	Wed		12	Sat		12	Mon		12	Thur			Ghatastapna	12	Sat
13	Mon	UG Term Start	13	Thur		13	Sun		13	Tues		13	Fri	Unit Test II			13	Sun
14	Tues		14	Fri		14	Mon	Project Stage Activity- I	14	Wed		14	Sat		Feed back II		14	Mon
15	Wed		15	Sat	Independence Day	15	Tues		15	Thur		15	Sun			SPPU Theory Exam / TH Exam	15	Tues
16	Thur		16	Sun		16	Wed		16	Fri		16	Mon	SPPU UG-POE			16	Wed
17	Fri		17	Mon		17	Thur		17	Sat		17	Tues		SPPU UG-POE		17	Thur
18	Sat		18	Tues		18	Fri	APR I	18	Sun		18	Wed			SPPU UG-POE	18	Fri
19	Sun		19	Wed		19	Sat		19	Mon		19	Thur	SPPU UG-POE			19	Sat
20	Mon		20	Thur		20	Sun		20	Tues		20	Fri		SPPU UG-POE		20	Sun
21	Tues		21	Fri	Ganesh Chaturthi	21	Mon		21	Wed		21	Sat			SPPU UG-POE	21	Mon
22	Wed		22	Sat		22	Tues	Unit Test I	22	Thur		22	Sun	SPPU UG-POE			22	Tues
23	Thur		23	Sun		23	Wed		23	Fri		23	Mon		SPPU UG-POE		23	Wed
24	Fri		24	Mon		24	Thur	Feed back I	24	Sat		24	Tues			SPPU UG-POE	24	Thur
25	Sat		25	Tues		25	Fri		25	Sun		25	Wed	SPPU UG-POE			25	Fri
26	Sun		26	Wed		26	Sat		26	Mon		26	Thur		SPPU UG-POE		26	Sat
27	Mon		27	Thur		27	*Sun		27	Tues		27	Fri			SPPU UG-POE	27	Sun
28	Tues		28	Fri		28	Mon		28	Wed		28	Sat	SPPU UG-POE			28	Mon
29	Wed		29	Sat		29	Tues		29	Thur	APR III	29	Sun		SPPU UG-POE		29	Tues
30	Thur		30	Sun		30	Wed		30	Fri	Idd-e-Milad	30	Mon			SPPU UG-POE	30	Wed
31	Fri		31	Mon					31	Sat				SPPU UG-POE			31	Thur

No. of working day=17      No. of working day=23      No. of working day =25      No. of working day =24      No. of working day=06      Total academic working days=95

Holiday  
 Weekly Off

APR Academic Progress Report  
 SPPU-POE- SPPU Practical/Oral Examination

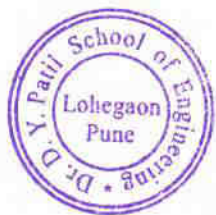

H. O. D.  
 Dept. of Mechanical Engg.  
 Dr. D. Y. Patil School of Engg., Lohegaon, Pune.



Dr. D. Y. Patil Educational Enterprises Charitable Trust's  
**Dr. D. Y. PATIL SCHOOL OF ENGINEERING & TECHNOLOGY**  
 Dr. D. Y. Patil Knowledge City, Charholi (Bk.), Via. Lohgaon, Pune - 412 105

Term I Academic Calender																	
JULY			AUGUST			SEPTEMBER			OCTOBER			NOVEMBER			DECEMBER		
Date	Day	Activity	Date	Day	Activity	Date	Day	Activity	Date	Day	Activity	Date	Day	Activity	Date	Day	Activity
1	Wed		1	Sat	Bakri Idd	1	Tues	Anant Chaturdash	1	Thur		1	Sun		1	Tues	
2	Thur		2	Sun		2	Wed		2	Fri	Mahatma Gaudhi Jayanti	2	Mon		2	Wed	
3	Fri		3	Mon	Rakshabandhan	3	Thur		3	Sat		3	Tues		3	Thur	
4	Sat		4	Tues		4	Fri		4	Sun		4	Wed		4	Fri	
5	Sun		5	Wed		5	Sat		5	Mon		5	Thur		5	Sat	
6	Mon		6	Thur		6	Sun		6	Tues	Project Stage Activity- II	6	Fri		6	Sun	
7	Tues		7	Fri		7	Mon		7	Wed		7	Sat	Unit Test III	7	Mon	
8	Wed		8	Sat		8	Tues		8	Thur		8	Sun		Project Stage Activity- III	8	Tues
9	Thur		9	Sun		9	Wed		9	Fri	APR II	9	Mon			UG Term End as per SPPU	9
10	Fri		10	Mon		10	Thur		10	Sat		10	Tues	SPPU Theory Exam / TH Exam			10
11	Sat		11	Tues		11	Fri		11	Sun		11	Wed		SPPU UG-POE		11
12	Sun		12	Wed		12	Sat		12	Mon		12	Thur			SPPU UG-POE	12
13	Mon	UG Term Start	13	Thur		13	Sun		13	Tues		13	Fri	SPPU UG-POE			13
14	Tues		14	Fri		14	Mon	Project Stage Activity- I	14	Wed	Unit Test II	14	Sat		SPPU UG-POE		14
15	Wed		15	Sat	Independence Day	15	Tues		15	Thur	Feed back II	15	Sun			SPPU UG-POE	15
16	Thur		16	Sun		16	Wed		16	Fri		16	Mon	SPPU UG-POE			16
17	Fri		17	Mon		17	Thur		17	Sat	Ghatastapna	17	Tues		SPPU UG-POE		17
18	Sat		18	Tues		18	Fri	APR I	18	Sun		18	Wed			SPPU UG-POE	18
19	Sun		19	Wed		19	Sat		19	Mon		19	Thur	SPPU UG-POE			19
20	Mon		20	Thur		20	Sun		20	Tues		20	Fri		SPPU UG-POE		20
21	Tues		21	Fri	Ganesh Chaturthi	21	Mon		21	Wed		21	Sat			SPPU UG-POE	21
22	Wed		22	Sat		22	Tues		22	Thur	Unit Test I	22	Sun	SPPU UG-POE			22
23	Thur		23	Sun		23	Wed		23	Fri	Feed back I	23	Mon		SPPU UG-POE		23
24	Fri		24	Mon		24	Thur		24	Sat		24	Tues			SPPU UG-POE	24
25	Sat		25	Tues		25	Fri		25	Sun		25	Wed	SPPU UG-POE			25
26	Sun		26	Wed		26	Sat		26	Mon		26	Thur		SPPU UG-POE		26
27	Mon		27	Thur		27	Sun		27	Tues		27	Fri			SPPU UG-POE	27
28	Tues		28	Fri		28	Mon		28	Wed		28	Sat	SPPU UG-POE			28
29	Wed		29	Sat		29	Tues		29	Thur	APR III	29	Sun		SPPU UG-POE		29
30	Thur		30	Sun		30	Wed		30	Fri	Idd-e-Milad	30	Mon			SPPU UG-POE	30
31	Fri		31	Mon					31	Sat				SPPU UG-POE			31

No. of working day=17      No. of working day=23      No. of working day =25      No. of working day =24      No. of working day=06      Total academic working days=95

  Holiday  
  Weekly Off  
 APR Academic Progress Report  
 SPPU-POE- SPPU Practical/Oral Examination

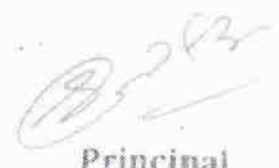

  
**Principal**  
 Dr. D. Y. Patil School of Engineering,  
 Lohgaon, Pune.



Dr. D. Y. Patil Educational Enterprises Charitable Trust's  
**Dr. D. Y. PATIL SCHOOL OF ENGINEERING & TECHNOLOGY**  
 Dr. D. Y. Patil Knowledge City, Charholi (Bk.), Via. Lohgaon, Pune - 412 105

### Academic Calender

Term II												Academic Year 2020-21			
February			March			April			May			June			
Date	Day	Activity	Date	Day	Activity	Date	Day	Activity	Date	Day	Activity	Date	Day		
1	Mon	UG-Sem Start	1	Mon	APR II	1	Thur	SMADL II	1	Sat	Maharashtra a Din	1	Tues		
2	Tues		2	Tues	SMADL I	2	Fri	Good Friday	2	Sun		2	Wed		
3	Wed		3	Wed		3	Sat		3	Mon	APR VI, FBA II	3	Thur		
4	Thur		4	Thur	Feedback I	4	Sun		4	Tues	SMADL III	4	Fri		
5	Fri		5	Fri		5	Mon		5	Wed	UTMS II	5	Sat		
6	Sat		6	Sat		6	Tues		6	Thur		6	Sun		
7	Sun		7	Sun		7	Wed		7	Fri	UG Term End	7	Mon		
8	Mon		8	Mon		8	Thur		8	Sat		8	Tues		
9	Tues		9	Tues		9	Fri		9	Sun		9	Wed		
10	Wed		10	Wed	FBA I	10	Sat		10	Mon		10	Thur		
11	Thur		11	Thur	Mahashivra tri	11	Sun		11	Tues		11	Fri		
12	Fri		12	Fri		12	Mon		12	Wed		12	Sat		
13	Sat		13	Sat		13	Tues	Gudipadwa	13	Thur	Ramjan Idd	13	Sun		
14	Sun		14	Sun		14	Wed	Dr. Ambedkar Jayanti	14	Fri		14	Mon		
15	Mon	APR I	15	Mon	APR III	15	Thur		15	Sat		15	Tues		
16	Tues		16	Tues	UTMS I	16	Fri		16	Sun		16	Wed		
17	Wed		17	Wed		17	Sat		17	Mon		17	Thur		
18	Thur		18	Thur		18	Sun		18	Tues		18	Fri		
19	Fri	Shivaji Maharaj Jayanti	19	Fri		19	Mon	APR V	19	Wed		19	Sat		
20	Sat		20	Sat		20	Tues		20	Thur		20	Sun		
21	Sun		21	Sun		21	Wed	Ramnavmi	21	Fri		21	Mon		
22	Mon		22	Mon		22	Thur		22	Sat	* SPPU-POE Practical Exam UG and PG	22	Tues		
23	Tues		23	Tues		23	Fri		23	Sun		23	Wed		
24	Wed		24	Wed		24	Sat		24	Mon		24	Thur		
25	Thur		25	Thur		25	Sun		25	Tues		25	Fri		
26	Fri		26	Fri		26	Mon		26	Wed		26	Sat		
27	Sat		27	Sat		27	Tues		27	Thur		27	Sun		
28	Sun		28	Sun		28	Wed		28	Fri		28	Mon		
			29	Mon	Holi	29	Thur		29	Sat		29	Tues		
			30	Tues	APR IV	30	Fri	Feedback II	30	Sun		30	Wed		
			31	Wed					31	Mon					
No. of working day=24			No. of working day=21			No. of working day=18			No. of working day=05			Total academic work days=68			

UTMS- Unit test marks submission

APR - Academic Progress Report

SMADL- Student monthly attendance & defaulter list

Note: \* denotes that mention dates are tentative

FBA- Feedback analysis

UT: Unit Test

SPPU-POE- SPPU Practical/Oral Examination

Prof. Riyaj Kazi  
 IQAC -Coordinator

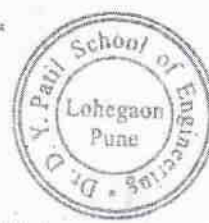

Dr. F B SAYYAD  
 Principal



Dr. D. Y. Patil Technical Campus

# **Dr. D. Y. Patil School of Engineering**

Dr. D. Y. Patil Knowledge City, Charholi (Bk), Lohegaon, Pune – 412 105

20) Departmental Meetings.

**Minutes of Meeting**

**Ref. No.:** DYPSOE/E&TC-Dept/AY 2020-21/Meeting No. 04

**Date of Meeting:** 14<sup>th</sup> January 2021, Time: 11:15 AM

**Venue:** CL-II Lab (Room No 231)

**Agenda of Meeting**

1. IQAC plan of action
2. DSE teaching
3. Any other issue

**Presided By:** Dr. Sanjay Koli

**Points Discussed**

1. The plan of action prepared by IQAC was discussed in the meeting. HoD has instructed all the staff to work towards the fulfillment of various requirements of action plan.
2. It has been instructed to faculties to repeat the teaching workload for DSE students once they report to college.
3. The student's feedback-II is given to faculties.

**Resolutions**



- 1) It has been decided to work on plan of action given by IQAC.
- 2) It has been decided to repeat teaching workload to DSE students once they report to college.

  
Ms. Pallavi Patil  
Prepared By

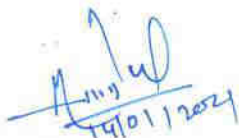
  
Dr. Sanjay Koli  
HoD-E&TC

  
Dr. Ashok Kasnale  
Principal

Following Teaching and non-teaching staff were present for the meeting

Sr. No.	Name of Staff	Sign
1.	Dr. S. M. Koli	
2.	Dr. S. M. Anwar	



3.	Swati Khawate	
4.		
5.	Ashwini Bogde	
6.	Dr. Rashmi Mehajan	
7.	Riyaj L. Kazi	
8.	Prajakta Kharwar	
9.	Gaurav Misra	
10.	Pallavi Patil	

- 11 Shital Patil  
 12 Aniket Zonde  
 13 Kamble Snehatkar  
 14 Jagtap Rubuja.

  
  
  
 HoD-E&TC  





"Empowerment through quality technical education"

**Dr. D. Y. Patil School of Engineering**  
**Dr. D. Y. Patil School of Engineering & Technology**  
 Dr. Ajeenkya DY Patil Knowledge City, Charholi Bk., Via. Lohegaon, Pune – 412 105

**Minutes of Meeting**

<b>Meeting</b>	HoD with all staff and Dean (Academics)
<b>Date</b>	04/03/2021 Time 12.30PM-12.45PM
<b>Location</b>	IFP Lab
<b>Chairperson</b>	Prof. Rohit Garad, HoD
<b>In Attention</b>	All staff and Dean Academics of SOE
<b>Discussion</b>	<p><b>HoD sir informed to all Staff about Department related activities need to complete for NAAC.</b></p> <ol style="list-style-type: none"> <li>1) Guest Lecture- Academic related guest lecture, Alumni Guest lecture, and Competitive exam: MPSC/UPSC/GATE etc, crosscutting issues and value education, Bridge the gap- On recent technology.</li> <li>2) Add on /Certificate programs for students</li> <li>3) NPTEL (Certification course)/Each staff</li> <li>4) Visits - Field visits, Industrial visits, Visit to Expo. As per syllabus</li> <li>5) STTP/FDP(one week), Workshop(Two days), Seminar/Each Department</li> <li>6) FDP/Workshop/STTP per faculty</li> <li>7) Paper publication/Each Faculty</li> <li>8) Paper publication in National/ International conference</li> <li>9) Research Grant (proposal) / Per Faculty</li> <li>10) Membership of professional Body / Each faculty</li> <li>11) Activity should be conducted under each MoU (Internship/ Sponsored project under MoU/ Field Visits/ Guest lecture/Seminar/ Workshop/ Consultancy/ Faculty or student exchange)</li> <li>12) Book Published/Chapter edited/ Patent filing/ Consultancy Services</li> <li>13) Soft skill development program</li> <li>14) Parents teacher meet</li> </ol>



**HoD sir informed to all Staff about Institute related activities required for NAAC like,**

- 1) Convocation and farewell
- 2) Extension and outreach programs conducted by the institution through NSS/NCC/Red cross/YRC
- 3) Life skills (Yoga, physical fitness, health and hygiene) workshop
- 4) Induction Program for FE and DSE
- 5) Technical Events and Sports
- 6) Admin/Non-teaching staff development program
- 7) Internal Academic Audit
- 8) Startup/Incubation center

**HoD sir informed to all Staff about Departmental Administration related activities required for NAAC.**

1. Course File Checking including CO/PO attainment
2. Result Analysis
3. Faculty appreciation/ action taken report
4. Student assessment record
5. Stakeholder feedback analysis
6. Mentor Activity Reports

**Resolutions**

1. 1) It has been resolved that Every Staff should arrange Guest Lecture such as Academic related guest lecture, Alumni Guest lecture, Competitive Exam. GL such as MPSC/UPSC/GATE etc.,
- 2) Every staff should register for NPTEL (Certification course), STTP/FDP (one week), Workshop (Two days), Seminar, FDP/Workshop/STTP.
- 3) All faculty should publish at least one Paper in UGC approved Journals & prepare at least 1 Research Grant (proposal) /Faculty
- 4) Every staff should take a Membership of professional Body. Under MOU perform activities such as: Internship/ Sponsored project under MoU/ Field Visits/ Guest lecture/Seminar/ Workshop/ Consultancy/ Faculty or student exchange. Staff can complete one activity from



	<p>Book Published/Chapter edited/ Patent filing/ Consultancy Services.</p> <p>5) It has been resolved to plan Parents teacher meet, Soft skill development program</p>
	<p>2. It has been resolved that concern Staff should plan institute related activities such as Convocation and farewell, extension and outreach programs conducted by the institution through NSS/NCC/Red cross/YRC, Life skills (Yoga, physical fitness, health and hygiene) workshop, Induction Program for FE and DSE, Technical Events and Sports, Admin/Non-teaching staff development program, Internal Academic Audit, Startup/Incubation center</p>
	<p>3. It has been resolved that Concern staff should complete departmental administration related activities such as Course File Checking including CO/PO attainment, Result Analysis, Faculty appreciation/ action taken report, Student assessment record, Stakeholder feedback analysis, Mentor Activity Reports</p>



**Prof. Rohit Garad**  
**HoD ( Mech)**

H. O. D.  
Dept. of Mechanical Engg.  
Dr. D. Y. Patil School of Engg., Lohegaon, Pune



DR. D. Y. PATIL GROUP

Dr. D. Y. Patil Group of Institution's Technical Campus

## Dr. D. Y. PATIL SCHOOL OF ENGINEERING

Dr. D. Y. Patil Knowledge City, Charoli Bk., Via. Lohegaon, Pune - 412 105

### Department of Civil Engineering

#### Minutes of Meeting

Ref No: DYP SOE/ Civil Dept/AY 2020-21/Sem II/Meeting No.

Date of Meeting : 05/1/2020

Venue : Teams App

Agenda of Meeting: Plan of action for IQAC.

Sr. No.	Points discussed	Remark
1.	HoD discussed the points that were highlighted by the Principal in meeting of Heads of Department and his subsequent directions.	
2.	<p>Following points were discussed and deliberated upon.</p> <ul style="list-style-type: none"><li>• CO PO Mapping should be done after every result analysis. All faculties should complete the course file accordingly; the activity will be monitored by A.A.Ingle.</li><li>• Review of result analysis to be done by Prof.U.A.Kakde.</li><li>• Prof.R.D.Koshti must plan a FDP/Workshop and STTP by month end.</li><li>• All faculties should attend one NPTL course and this will be monitored by Prof.Pragya Sharma</li><li>• Activities to be initiated at departmental and institute level from criteria I to VII to be monitored by Prof.Aradhna Ganvir.</li><li>• Consultancy activities for revenue generation i.e. NABL LAB to be monitored by Prof.A.V.Nemade</li><li>• Patents filing in Transportation should be done by Prof.Pragya Sharma and in Hydrology by Prof.R.C.Katdare.</li><li>• To achieve 95% placement in department HoD instructed Prof. Aradhna Ganvir to make a report on the loopholes in existing system used and what problems students are facing in placement activities.</li><li>• Prof. Uzma Shaikh and Prof.U.A.Kakde should check whether all the existing MoUs are functional. Prof.R.D.Koshti will make one new MoU in this month.</li><li>• Feedback from parents to be taken before submissions, Prof.U.A.Kakde will monitor this activity.</li><li>• Prof.R.D.Koshti should arrange virtual Alumina Meet.</li></ul>	

Following Teaching staff has attended the meeting

Sr. No.	Name of the faculty
1.	Prof. S. M Karodpati
2.	Prof. R.D.Koshti
3.	Prof.U.A.Kakde
4.	Prof.AradhanaGanvir
5.	Prof. Aakanksha Ingle
6.	Prof. Pragya Sharma
7.	Prof. AniketNemade
8.	Prof.PrasadGayake



**Prof. Aakanksha Ingle**

Prepared By



**Prof. S. M. Karodpati**

H.O.D.  
H.O.D.

Department of Civil Engineering  
Dr. D. Y. Patil School of Engg. Lohegaon



Dr. D. Y. Patil Technical Campus

# **Dr. D. Y. Patil School of Engineering**

Dr. D. Y. Patil Knowledge City, Charholi (Bk), Lohegaon, Pune – 412 105

17) College Website-Related Material  
Uploading -  
Powerpoint Presentations, Notes,  
Videos, Films, Link Etc.



- Dashboard
- Site Home
- Calendar
- Private files
- Content bank
- My courses
- SOENETC-555
- SOENETC-559
- SOENETC-954
- Add a block

## BE Broadband Communication Systems

Dashboard / My courses / SOEENETC\_BCS

**Announcements**

- BCS UNIT TEST 1, 3-5-2021**  
 Not available unless:
  - It is after 8 March 2021, 3:00 PM
  - It is before 8 March 2021, 4:00 PM
- EE\_BCS\_SPPU Intern Exam 2020-21, Sem II**  
 Available from 30 May 2021, 3:00 PM
- ECS Intern exam for dairy forward student 2-5-2021**  
 Available from 2 July 2021, 11:00 AM

**Material for students**

Time Table\_AY\_2...docx  
Removed

3:10 PM 26-Nov-21

BCS Lab Manual.pdf

BCS Lab Manual.pdf

Time Table\_AY\_2...docx  
Removed

Show all





BE BCS online lectures

- Unit 1
- Unit 2
- Unit 3
- Unit 4
- Unit 5
- Unit 6
- Site Home
- Calendar
- Private Files
- Content Bank
- My courses
- SCREENING-250
- SCREENING-252
- SCREENING-254
- Add a block

- + BE BCS online lectures
  - + BCS lecture 2-2-2021 [View](#) [Edit](#)
  - + BCS lecture 3-2-2021 [View](#) [Edit](#)
  - + BCS lecture 4-2-2021 [View](#) [Edit](#)
  - + BCS lecture 5-2-2021 [View](#) [Edit](#)
  - + BCS lecture 10-2-2021 [View](#) [Edit](#)
  - + BCS lecture 11-2-2021 [View](#) [Edit](#)
  - + BCS lecture 18-2-2021 [View](#) [Edit](#)
  - + BCS lecture 23-2-2021 [View](#) [Edit](#)

BCS Lab Manual.pdf | BCS Lab Manual.pdf | Time Table\_AV\_Z...docx  
 Removed

Show all | Show desktop



← → ↻ ▲ Not secure | <https://dypic.adypuonline.in/course/view.php?id=284>

☰ DYPIC

SE BCS online lectures

- Unit 1
- Unit 2
- Unit 3
- Unit 4
- Unit 5
- Unit 6

[Dashboard](#) | [Site Home](#) | [Calendar](#) | [Private files](#) | [Content bank](#) | [My courses](#)

- SOENITC-ESD
- SOENITC-OSF
- SOENITC-PS-1
- Add a block

BCS Lab Manual.pdf

BCS Lab Manual.pdf

Time Table\_AY\_2...docx  
Removed

Show all X

+ BCS 78 1 24-6-2021 [View](#)

+ BCS 78 2 13-6-2021 [View](#)

+ BCS 78 3 17-6-2021 [View](#)

+ BCS 78 4 18-6-2021 [View](#)

+ Unit 1 [View](#)

+ Unit 2 [View](#)

+ Add an activity or resource

+ Add an activity or resource

+ Add an activity or resource

+ Add an activity or resource

[Home](#) | [Back](#) | [Forward](#) | [Refresh](#) | [Print](#) | [W](#)



Browser address bar: <https://dypicadypgonline.in/course/view.php?id=284>

Browser tabs: BCS Lab Manual.pdf, BCS Lab Manual.pdf, Time Table\_AY\_2....docx

Browser toolbar: Back, Forward, Home, Reload, Search, Print, etc.

Navigation menu:

- 35 SCS online lectures
- Unit 1
- Unit 2
- Unit 3
- Unit 4
- Unit 5
- Unit 6
- Dashboard
- Attendance
- Calendar
- Private files
- Content Bank
- My courses
- SCREENING
- SCREENING
- SCREENING
- SOEETC-PSJ
- Add a block

Main content area showing unit details:

- Unit 3**
  - Unit 3 ppt (Mark as done)
  - + Add an activity or resource
- Unit 4**
  - Unit 4 ppt (Mark as done)
  - + Add an activity or resource
- Unit 5**
  - Unit 5 ppt (Mark as done)
  - + Add an activity or resource
- Unit 6**
  - Unit 6 ppt (Mark as done)
  - + Add an activity or resource

Bottom toolbar:

- Navigation icons: Home, Back, Forward, etc.
- File icons: PDF, Word, etc.
- System tray: 3:13 PM, 26-Nov-20



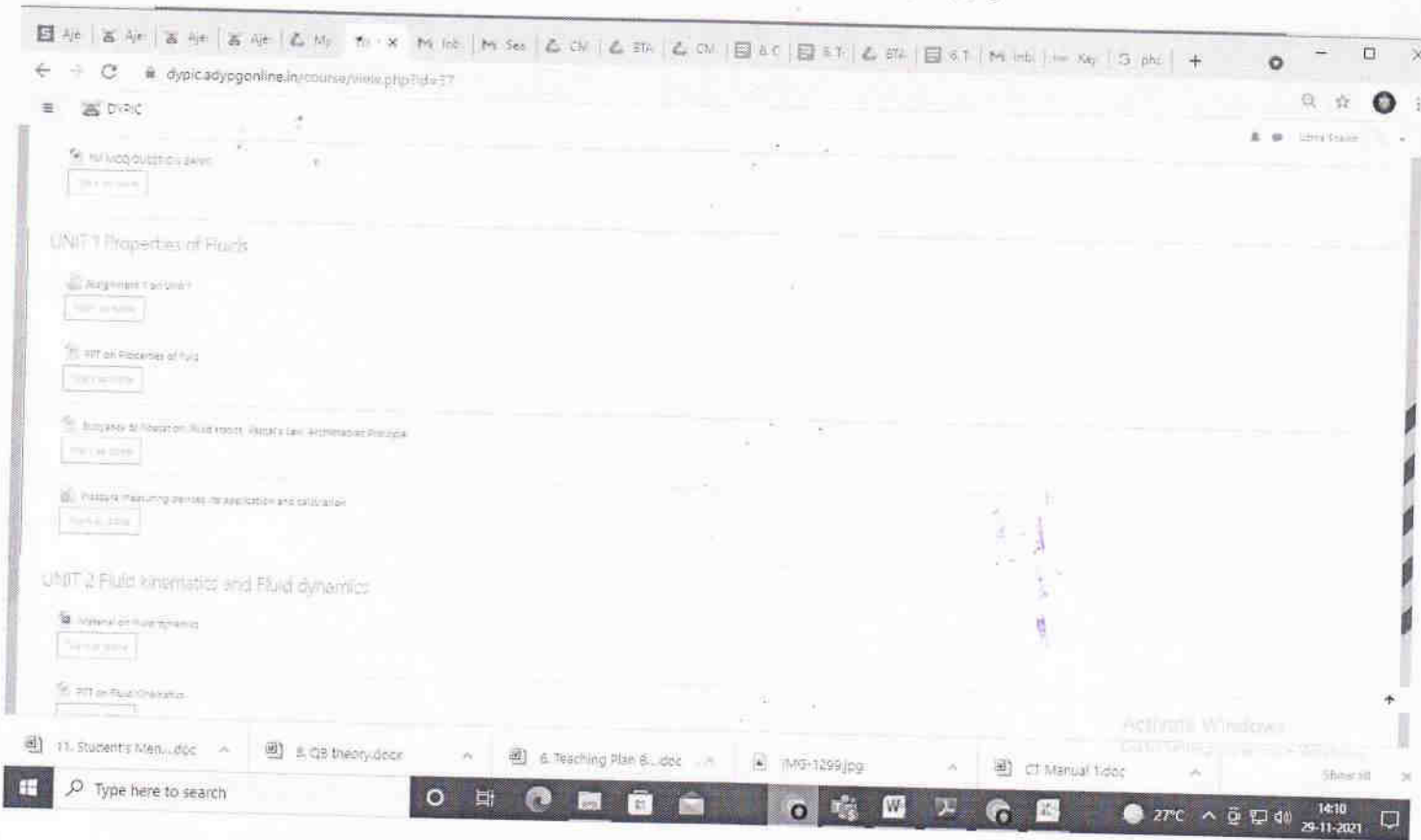

U.S.

Subject Teacher  
Prof. Uzma Shaikh



# UNIT V

## Pneumatic System



# Pneumatic System

- Pneumatic systems use pressurized compressible fluids.
- Air is the most common compressible fluid although some gasses are also used in pneumatic drives, specially where the gas itself is one of the product or byproduct where the system is being used.
- However, air is the environment friendly, cheap, safe and readily available fluid media for pneumatics.
- For general purpose actuator drives manageable with low pressure (usually below 2 MPa) pneumatic system is preferred over hydraulic system, where pressure may be as high as 80 MPa.



- ▶ However, position or actuation at controlled velocity is not achievable with compressible fluids.
- ▶ Pneumatic applications in such areas are rare and where hydraulic oil cannot be used due to environment reason.
- ▶ Also, less accurate performance is acceptable.
- ▶ In pneumatic systems compressors, typically the vane, lobe, screw or cylindrical piston type
- ▶ Positive displacement machines, are used to compress and store the air.



# Main Components of a Pneumatic System

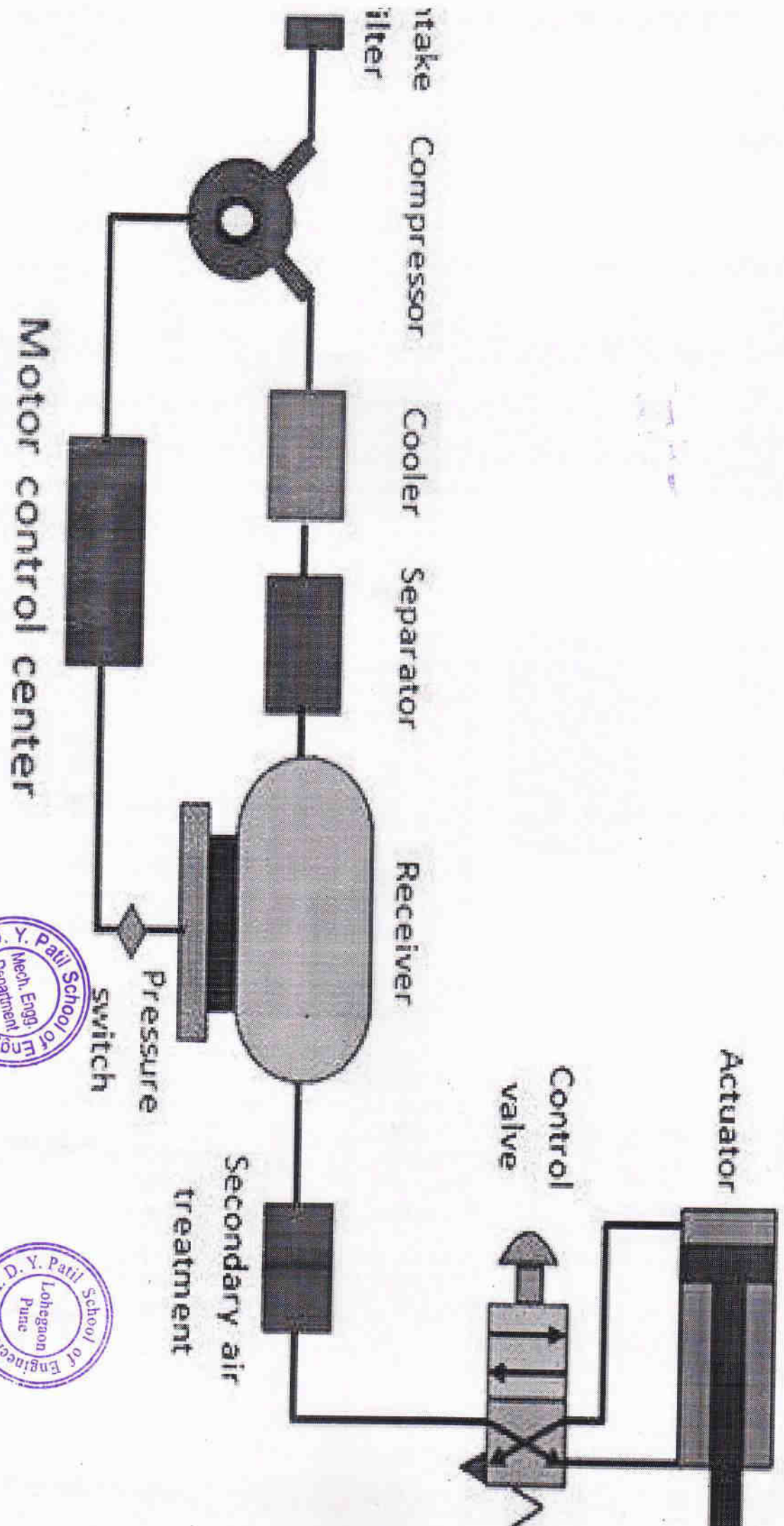

# Types of compressor

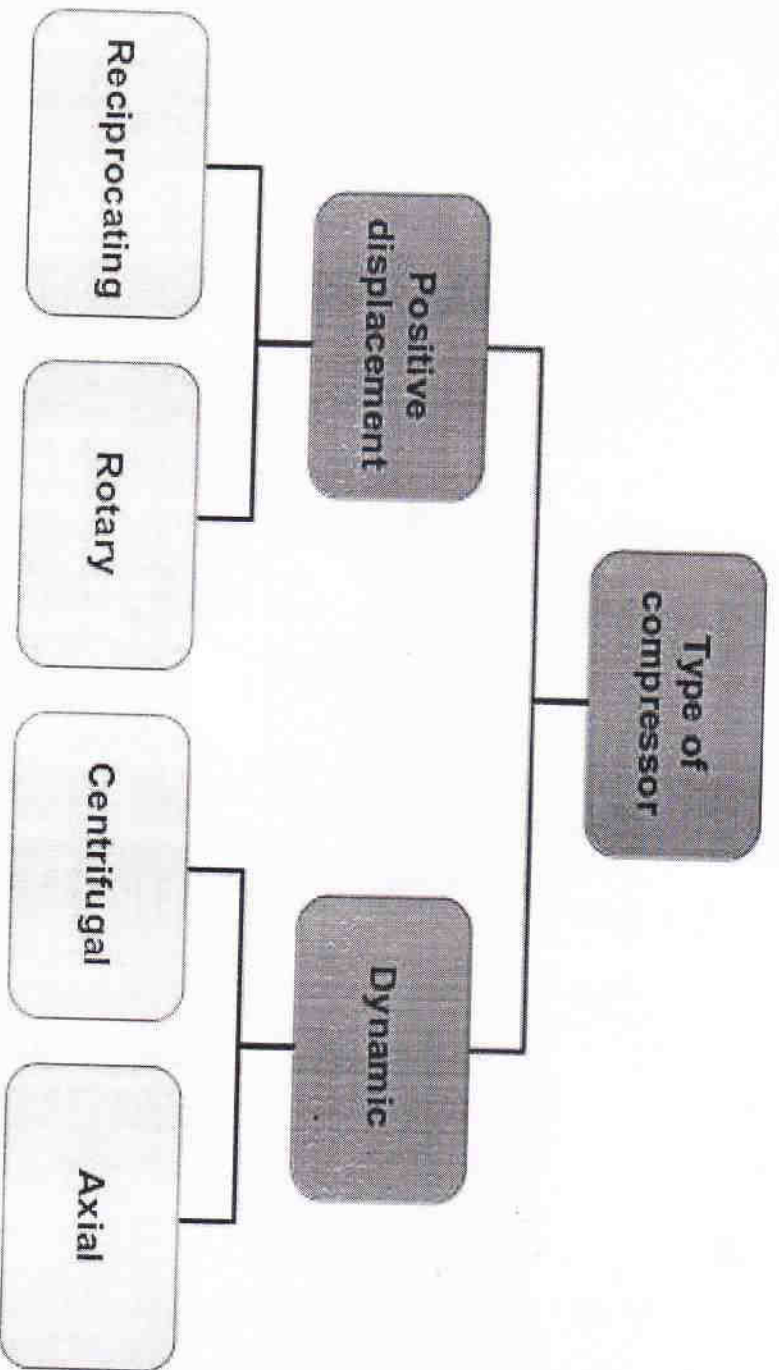

**Dr. D. Y. Patil Technical Campus**

# **Dr. D. Y. Patil School of Engineering**

Dr. D. Y. Patil Knowledge City, Charholi (Bk), Lohegaon, Pune – 412 105

## **21) Student Lists**



"Empowerment through quality technical education"  
Dr D Y Patil Educational Enterprises Charitable Trust's

**Ajeenkya D Y Patil Group of Institution's Technical Campus**  
**Dr D Y PATIL SCHOOL OF ENGINEERING**

(Approved by AICTE, New Delhi Recognized by Govt. of Maharashtra, Affiliated to Savitribai Phule Pune University)  
AISHE Code: C-46648 DTE Code: EN6732 SPPU PUN Code: CEGP015720  
**(Accredited by NAAC)**

**A.Y. 2020-21**

**Approved year wise & branch wise admission list**

(Criteria 2.1.1)

UG/PG	Program Name	Number of students admitted
UG	Civil Engg.	18
	Computer Engg.	136
	E&TC Engg.	50
	Mechanical Engg.	09
	AI&DS Engg.	67
PG	Computer Engg.	01
	Mechanical Engg.	04
	E&TC Engg	01

**Dr. F. B. Sayyad**

**Principal**

Enclosed: List of Students.

# Dr. D. Y. Patil School of Engineering , Charholi(Bk), Via Lohgaon, Pune

**MAHADBT Portal Online Apply for Various Scholarship A.Y.2020-21**

**Final Admission List Indicating The Categories A.Y. 2020.21**

Sr. No.	Application ID	Candidate Name	Gender	Institute Name	Course Name	Category
1	EN20174609	AYUSH AMAR MADIKUNT	Male	Dr. D. Y. Patil School OF Engineering, Lohegaon, Pune	Civil Engineering	Open
2	EN20143489	BHANDARE ROHAN KALYAN	Male	Dr. D. Y. Patil School OF Engineering, Lohegaon, Pune	Civil Engineering	NT 2 (NT-C)
3	EN20160406	BORSE RUSHIKESH RAMESHWAR	Male	Dr. D. Y. Patil School OF Engineering, Lohegaon, Pune	Civil Engineering	NT 2 (NT-C)
4	EN20230966	CHAVAN VISHAL SURESH	Male	Dr. D. Y. Patil School OF Engineering, Lohegaon, Pune	Civil Engineering	NT 1 (NT-B)
5	EN20166590	CHAVHAN RAMESHWAR PRAKASH	Male	Dr. D. Y. Patil School OF Engineering, Lohegaon, Pune	Civil Engineering	Open
6	EN20225722	DONGARE MAYURI DATTATRAYA	Female	Dr. D. Y. Patil School OF Engineering, Lohegaon, Pune	Civil Engineering	OBC
7	EN20208006	JADHAV BHUSHAN RAJENDRA	Male	Dr. D. Y. Patil School OF Engineering, Lohegaon, Pune	Civil Engineering	NT 1 (NT-B)
8	EN20214889	KAMBLE PRANIT VINAY	Male	Dr. D. Y. Patil School OF Engineering, Lohegaon, Pune	Civil Engineering	SC
9	EN20227814	KHAMKAR PAWANRAJ MARUTI	Male	Dr. D. Y. Patil School OF Engineering, Lohegaon, Pune	Civil Engineering	Open
10	EN20122956	KORDE HARSHAL RAMAKANT	Male	Dr. D. Y. Patil School OF Engineering, Lohegaon, Pune	Civil Engineering	OBC
11	EN20116789	LABDHE MIHIR BHARAT	Male	Dr. D. Y. Patil School OF Engineering, Lohegaon, Pune	Civil Engineering	OBC
12	EN20201266	METTELU ARYAN NARENDRA KUMAR	Male	Dr. D. Y. Patil School OF Engineering, Lohegaon, Pune	Civil Engineering	Open
13	EN20249705	PAWAR CHAITANYA PRADEEP	Male	Dr. D. Y. Patil School OF Engineering, Lohegaon, Pune	Civil Engineering	Open
14	EN20207249	SHAIKH JUNAID YAKUB	Male	Dr. D. Y. Patil School OF Engineering, Lohegaon, Pune	Civil Engineering	Open
15	EN20215233	SHIRKE SHIVRAJ NIVRUTTI	Male	Dr. D. Y. Patil School OF Engineering, Lohegaon, Pune	Civil Engineering	Open
16	EN20134880	SONONE RAJ ASHOK	Male	Dr. D. Y. Patil School OF Engineering, Lohegaon, Pune	Civil Engineering	OBC
17	EN20228136	KANGUDE ASHUTOSH SATISH	Male	Dr. D. Y. Patil School OF Engineering, Lohegaon, Pune	Civil Engineering	Open
18	EN20130489	KAPALE ATHARVA SHAILENDRA	Male	Dr. D. Y. Patil School OF Engineering, Lohegaon, Pune	Civil Engineering	OBC
19	EN20115695	SAWANT SHIVANI SHANKAR	Female	Dr. D. Y. Patil School OF Engineering, Lohegaon, Pune	Computer Engineering	Open
20	EN20213634	AADITYA AGARWAL	Male	Dr. D. Y. Patil School OF Engineering, Lohegaon, Pune	Computer Engineering	Not Applicable
21	EN20113796	AAKASH MANISH AYACHIT	Male	Dr. D. Y. Patil School OF Engineering, Lohegaon, Pune	Computer Engineering	Open
22	EN20221593	ADITYA SINGH	Male	Dr. D. Y. Patil School OF Engineering, Lohegaon, Pune	Computer Engineering	Not Applicable
23	EN20134290	ALI MEHLAM PARVEZ	Male	Dr. D. Y. Patil School OF Engineering, Lohegaon, Pune	Computer Engineering	Open
24	EN20180144	ANAND SONWANE	Male	Dr. D. Y. Patil School OF Engineering, Lohegaon, Pune	Computer Engineering	Not Applicable
25	EN20221455	ANSHUL JAWA	Male	Dr. D. Y. Patil School OF Engineering, Lohegaon, Pune	Computer Engineering	Not Applicable
26	EN20142225	ANURAG KUMAR	Male	Dr. D. Y. Patil School OF Engineering, Lohegaon, Pune	Computer Engineering	Not Applicable
27	EN20120764	BAGUL YASH SUNIL	Male	Dr. D. Y. Patil School OF Engineering, Lohegaon, Pune	Computer Engineering	SC
28	EN20134751	BALINGE BHARGAV NITIN	Male	Dr. D. Y. Patil School OF Engineering, Lohegaon, Pune	Computer Engineering	OBC
29	EN20132106	BALSARAF GARGI RAJESH	Female	Dr. D. Y. Patil School OF Engineering, Lohegaon, Pune	Computer Engineering	OBC
30	EN20152653	BELOKAR VEDRAJ HEMANT	Male	Dr. D. Y. Patil School OF Engineering, Lohegaon, Pune	Computer Engineering	OBC
31	EN20210727	BHALERAO SAMRUDHA GANESH	Male	Dr. D. Y. Patil School OF Engineering, Lohegaon, Pune	Computer Engineering	SC
32	EN20202634	BHAMARE SAURABH RAKESH	Male	Dr. D. Y. Patil School OF Engineering, Lohegaon, Pune	Computer Engineering	OBC
33	EN20217010	BHOSALE SAKTHAK SANTOSH	Male	Dr. D. Y. Patil School OF Engineering, Lohegaon, Pune	Computer Engineering	OBC
34	EN20161113	BHUJBAL SARSHI SUHAS	Female	Dr. D. Y. Patil School OF Engineering, Lohegaon, Pune	Computer Engineering	OBC
35	EN20134537	C J ARUNIMA	Female	Dr. D. Y. Patil School OF Engineering, Lohegaon, Pune	Computer Engineering	Open
36	EN20114811	CHAITHANYA H	Female	Dr. D. Y. Patil School OF Engineering, Lohegaon, Pune	Computer Engineering	Open
37	EN20226932	CHANDNI SHIVBARAN YADAV	Female	Dr. D. Y. Patil School OF Engineering, Lohegaon, Pune	Computer Engineering	Open
38	EN20168321	CHAVAN SAMIKSHA MOHAN	Female	Dr. D. Y. Patil School OF Engineering, Lohegaon, Pune	Computer Engineering	Open
39	EN20173512	CHETAN KHARWAR	Male	Dr. D. Y. Patil School OF Engineering, Lohegaon, Pune	Computer Engineering	Not Applicable
40	EN20151472	DAKSHATA NEGI	Female	Dr. D. Y. Patil School OF Engineering, Lohegaon, Pune	Computer Engineering	Not Applicable
41	EN20200684	DESHMUKH ROHIT RAJENDRA	Male	Dr. D. Y. Patil School OF Engineering, Lohegaon, Pune	Computer Engineering	Open
42	EN20212009	DHASAL RUSHIKESH YANANATH	Male	Dr. D. Y. Patil School OF Engineering, Lohegaon, Pune	Computer Engineering	OBC
43	EN20160226	DHOTRE KAUSTUBH RAJENDRA	Male	Dr. D. Y. Patil School OF Engineering, Lohegaon, Pune	Computer Engineering	OBC

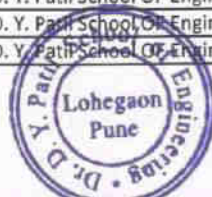



44	EN20174748	DIVYANSH SINGH SIKARWAR	Male	Dr. D. Y. Patil School OF Engineering, Lohegaon, Pune	Computer Engineering	Not Applicable
45	EN20136585	GAIKWAD MILIND MOHANRAO	Male	Dr. D. Y. Patil School OF Engineering, Lohegaon, Pune	Computer Engineering	SC
46	EN20115803	GAIKWAD TANMAY VINOD	Male	Dr. D. Y. Patil School OF Engineering, Lohegaon, Pune	Computer Engineering	SC
47	EN20153792	GAIKWAD VEDANT SHASHIKANT	Male	Dr. D. Y. Patil School OF Engineering, Lohegaon, Pune	Computer Engineering	OBC
48	EN20220919	GAVLI PRANJALI JAGANATH	Female	Dr. D. Y. Patil School OF Engineering, Lohegaon, Pune	Computer Engineering	NT 2 (NT-C)
49	EN20160510	GODHAM AADITYA BANDU	Male	Dr. D. Y. Patil School OF Engineering, Lohegaon, Pune	Computer Engineering	SC
50	EN20143120	GOLAIT TEJAS KRISHNA	Male	Dr. D. Y. Patil School OF Engineering, Lohegaon, Pune	Computer Engineering	SC
51	EN20226712	GOPAL KUMAR THAKUR	Male	Dr. D. Y. Patil School OF Engineering, Lohegaon, Pune	Computer Engineering	Not Applicable
52	EN20147846	GORLAWAR SAKSHI RAMESH	Female	Dr. D. Y. Patil School OF Engineering, Lohegaon, Pune	Computer Engineering	NT 1 (NT-B)
53	EN20157789	GUPTA SEJAL SUNIL	Female	Dr. D. Y. Patil School OF Engineering, Lohegaon, Pune	Computer Engineering	Open
54	EN20182953	HAJARE MAHESH SANJAY	Male	Dr. D. Y. Patil School OF Engineering, Lohegaon, Pune	Computer Engineering	SBC
55	EN20150679	HARSH ANAND NAIKWADE	Male	Dr. D. Y. Patil School OF Engineering, Lohegaon, Pune	Computer Engineering	OBC
56	EN20176675	HASE SIDDHANT AJIT	Male	Dr. D. Y. Patil School OF Engineering, Lohegaon, Pune	Computer Engineering	OBC
57	EN20226105	ISHAN PANDITA	Male	Dr. D. Y. Patil School OF Engineering, Lohegaon, Pune	Computer Engineering	Not Applicable
58	EN20228819	JADHAV DNYANESHWAR GANESH	Male	Dr. D. Y. Patil School OF Engineering, Lohegaon, Pune	Computer Engineering	Open
59	EN20123035	JADHAV SAMRUDDHI RAJESH	Female	Dr. D. Y. Patil School OF Engineering, Lohegaon, Pune	Computer Engineering	SC
60	EN20139074	JADHAV SUDARSHAN PRATAPRAO	Male	Dr. D. Y. Patil School OF Engineering, Lohegaon, Pune	Computer Engineering	Open
61	EN20132429	JADHAV SURAJ SANTOSH	Male	Dr. D. Y. Patil School OF Engineering, Lohegaon, Pune	Computer Engineering	Open
62	EN20120171	JAGDALE ROHIT KUMAR	Male	Dr. D. Y. Patil School OF Engineering, Lohegaon, Pune	Computer Engineering	Open
63	EN20132428	JAMLEKAR KHUSHI AMIT	Female	Dr. D. Y. Patil School OF Engineering, Lohegaon, Pune	Computer Engineering	SC
64	EN20117809	JANGID SUNIL NATHURAM	Male	Dr. D. Y. Patil School OF Engineering, Lohegaon, Pune	Computer Engineering	Open
65	EN20157892	KADAM MAYUR EKANATH	Male	Dr. D. Y. Patil School OF Engineering, Lohegaon, Pune	Computer Engineering	NT 1 (NT-B)
66	EN20147826	KADAM SHITAL NAGESH	Female	Dr. D. Y. Patil School OF Engineering, Lohegaon, Pune	Computer Engineering	Open
67	EN20183595	KADAM VAISHNAVI SANJAY	Female	Dr. D. Y. Patil School OF Engineering, Lohegaon, Pune	Computer Engineering	Open
68	EN20140442	KALE SAIRAJ SUNIL	Male	Dr. D. Y. Patil School OF Engineering, Lohegaon, Pune	Computer Engineering	Open
69	EN20123935	KAMBLE RUTUJA MAHENDRA	Female	Dr. D. Y. Patil School OF Engineering, Lohegaon, Pune	Computer Engineering	SC
70	EN20112422	KARCHE ASHISH VIKAS	Male	Dr. D. Y. Patil School OF Engineering, Lohegaon, Pune	Computer Engineering	OBC
71	EN20218260	KATORE ASHLESHA VIJAY	Female	Dr. D. Y. Patil School OF Engineering, Lohegaon, Pune	Computer Engineering	Open
72	EN20163946	KATORE PRATIK ASHOK	Male	Dr. D. Y. Patil School OF Engineering, Lohegaon, Pune	Computer Engineering	OBC
73	EN20122042	KAUSTUBH KANHAIYA JHA	Male	Dr. D. Y. Patil School OF Engineering, Lohegaon, Pune	Computer Engineering	Open
74	EN20169484	KHAIRE YASH DATTATRAY	Male	Dr. D. Y. Patil School OF Engineering, Lohegaon, Pune	Computer Engineering	Open
75	EN20206245	KOTKAR MANSI PRADIP	Female	Dr. D. Y. Patil School OF Engineering, Lohegaon, Pune	Computer Engineering	Open
76	EN20147892	KUMBHAR DHIRAJ PANDURANG	Male	Dr. D. Y. Patil School OF Engineering, Lohegaon, Pune	Computer Engineering	OBC
77	EN20214003	LOKWANI YUKTA SHRIKANT	Female	Dr. D. Y. Patil School OF Engineering, Lohegaon, Pune	Computer Engineering	Open
78	EN20111313	MAGAR AJINKYA SUNIL	Male	Dr. D. Y. Patil School OF Engineering, Lohegaon, Pune	Computer Engineering	OBC
79	EN20168322	MANE DAKSHATA SUNIL	Female	Dr. D. Y. Patil School OF Engineering, Lohegaon, Pune	Computer Engineering	Open
80	EN20126026	MATHUR DEVANG DINESH	Male	Dr. D. Y. Patil School OF Engineering, Lohegaon, Pune	Computer Engineering	Open
81	EN20169071	MEHARKAR APEKSHA RAMESH	Female	Dr. D. Y. Patil School OF Engineering, Lohegaon, Pune	Computer Engineering	OBC
82	EN20167250	MEHETRE ANSHUL SACHIN	Male	Dr. D. Y. Patil School OF Engineering, Lohegaon, Pune	Computer Engineering	OBC
83	EN20178021	METKARI ATHARV LAXMAN	Male	Dr. D. Y. Patil School OF Engineering, Lohegaon, Pune	Computer Engineering	NT 2 (NT-C)
84	EN20123903	MORE ATUL NARESH	Male	Dr. D. Y. Patil School OF Engineering, Lohegaon, Pune	Computer Engineering	Open
85	EN20155162	MUJUMDAR VAIDEHI VIVEK	Female	Dr. D. Y. Patil School OF Engineering, Lohegaon, Pune	Computer Engineering	Open
86	EN20144459	MUKUND PATHAK	Male	Dr. D. Y. Patil School OF Engineering, Lohegaon, Pune	Computer Engineering	Open
87	EN20172035	NANHE YASH REWARAM	Male	Dr. D. Y. Patil School OF Engineering, Lohegaon, Pune	Computer Engineering	NT 1 (NT-B)
88	EN20127829	NAVALE HARSHVARDHAN SUNIL	Male	Dr. D. Y. Patil School OF Engineering, Lohegaon, Pune	Computer Engineering	OBC
89	EN20165500	NAWALE PRATIK CHANDRABHAN	Male	Dr. D. Y. Patil School OF Engineering, Lohegaon, Pune	Computer Engineering	NT 3 (NT-D)
90	EN20159441	NETKE PRADNYA DHANANJAY	Female	Dr. D. Y. Patil School OF Engineering, Lohegaon, Pune	Computer Engineering	Open
91	EN20222752	NITIKA RAJ	Female	Dr. D. Y. Patil School OF Engineering, Lohegaon, Pune	Computer Engineering	Not Applicable
92	EN20129319	NIYATI CHANDRAMANI WANKHEDE	Female	Dr. D. Y. Patil School OF Engineering, Lohegaon, Pune	Computer Engineering	SC



93	EN20130993	OMKAR SUBHASH MULE	Male	Dr. D. Y. Patil School OF Engineering, Lohegaon, Pune	Computer Engineering	Open
94	EN20124640	PAITHANE RATNDEEP VIJAYKUMAR	Male	Dr. D. Y. Patil School OF Engineering, Lohegaon, Pune	Computer Engineering	SC
95	EN20162650	PATEL DEV MANOJBHAI	Male	Dr. D. Y. Patil School OF Engineering, Lohegaon, Pune	Computer Engineering	Not Applicable
96	EN20148877	PATIL GAURI KISHOR	Female	Dr. D. Y. Patil School OF Engineering, Lohegaon, Pune	Computer Engineering	Open
97	EN20113224	PATIL KARTIKEY PURUSHOTTAM	Male	Dr. D. Y. Patil School OF Engineering, Lohegaon, Pune	Computer Engineering	OBC
98	EN20221703	PATIL KSHITIJ HEMKANT	Male	Dr. D. Y. Patil School OF Engineering, Lohegaon, Pune	Computer Engineering	OBC
99	EN20184021	PATWE SUSHANT LILADHAR	Male	Dr. D. Y. Patil School OF Engineering, Lohegaon, Pune	Computer Engineering	Open
100	EN20160533	PIMPALKHARE RUTUJA ASHISH	Female	Dr. D. Y. Patil School OF Engineering, Lohegaon, Pune	Computer Engineering	Open
101	EN20125638	PRANAVRAJ LALASAHEB PAWAR	Male	Dr. D. Y. Patil School OF Engineering, Lohegaon, Pune	Computer Engineering	Open
102	EN20182441	PRANISHA PRADEEP MIRKHALKAR	Female	Dr. D. Y. Patil School OF Engineering, Lohegaon, Pune	Computer Engineering	Open
103	EN20182735	PRATIK LAXMAN KHADE	Male	Dr. D. Y. Patil School OF Engineering, Lohegaon, Pune	Computer Engineering	SC
104	EN20118901	PRIYA PRAKASH	Female	Dr. D. Y. Patil School OF Engineering, Lohegaon, Pune	Computer Engineering	Not Applicable
105	EN20158987	PRIYANSHI SUGANDHI	Female	Dr. D. Y. Patil School OF Engineering, Lohegaon, Pune	Computer Engineering	Not Applicable
106	EN20165777	RAJAT ACHARJEE	Male	Dr. D. Y. Patil School OF Engineering, Lohegaon, Pune	Computer Engineering	Not Applicable
107	EN20207608	RAJGURU RUSHIKESH SHASHIKANT	Male	Dr. D. Y. Patil School OF Engineering, Lohegaon, Pune	Computer Engineering	SC
108	EN20122764	RATHOD ANIL SURESH	Male	Dr. D. Y. Patil School OF Engineering, Lohegaon, Pune	Computer Engineering	DT/VJ
109	EN20208445	RAUT PRATHAMESH RANGNATH	Male	Dr. D. Y. Patil School OF Engineering, Lohegaon, Pune	Computer Engineering	OBC
110	EN20120379	RITIK SETH	Male	Dr. D. Y. Patil School OF Engineering, Lohegaon, Pune	Computer Engineering	Not Applicable
111	EN20154198	ROHIT RAI	Male	Dr. D. Y. Patil School OF Engineering, Lohegaon, Pune	Computer Engineering	Not Applicable
112	EN20118133	SADAF QAISH	Female	Dr. D. Y. Patil School OF Engineering, Lohegaon, Pune	Computer Engineering	Not Applicable
113	EN20110451	SAHIL SANTOSH TIMBOLE	Male	Dr. D. Y. Patil School OF Engineering, Lohegaon, Pune	Computer Engineering	Open
114	EN20120007	SALOKHE ABHISHEK UDAY	Male	Dr. D. Y. Patil School OF Engineering, Lohegaon, Pune	Computer Engineering	DT/VJ
115	EN20156898	SANKET BIPIN ABHANG	Male	Dr. D. Y. Patil School OF Engineering, Lohegaon, Pune	Computer Engineering	OBC
116	EN20122124	SANSKRUTI SATISH KHEDKAR	Female	Dr. D. Y. Patil School OF Engineering, Lohegaon, Pune	Computer Engineering	OBC
117	EN20111385	SAURABH SUKDEV WAMAN	Male	Dr. D. Y. Patil School OF Engineering, Lohegaon, Pune	Computer Engineering	OBC
118	EN20159657	SAYYED SADIYA SALIM	Female	Dr. D. Y. Patil School OF Engineering, Lohegaon, Pune	Computer Engineering	Open
119	EN20202140	SHAIKH YOUSUF MOHAMMAD KALEEM	Male	Dr. D. Y. Patil School OF Engineering, Lohegaon, Pune	Computer Engineering	Open
120	EN20139101	SHAILESH KUMAR YADAV	Male	Dr. D. Y. Patil School OF Engineering, Lohegaon, Pune	Computer Engineering	Open
121	EN20143526	SHARMA AYUSH	Male	Dr. D. Y. Patil School OF Engineering, Lohegaon, Pune	Computer Engineering	Open
122	EN20162708	SHEDGE MANAS SANJAY	Male	Dr. D. Y. Patil School OF Engineering, Lohegaon, Pune	Computer Engineering	Open
123	EN20122996	SHELAR SANSKRUTI VIJAY	Female	Dr. D. Y. Patil School OF Engineering, Lohegaon, Pune	Computer Engineering	SC
124	EN20118051	SHENDE ANURAG SANJAY	Male	Dr. D. Y. Patil School OF Engineering, Lohegaon, Pune	Computer Engineering	SC
125	EN20145625	SHINDE GAYATRI SANTOSH	Female	Dr. D. Y. Patil School OF Engineering, Lohegaon, Pune	Computer Engineering	NT 2 (NT-C)
126	EN20140561	SHINDE YASH PRAKASH	Male	Dr. D. Y. Patil School OF Engineering, Lohegaon, Pune	Computer Engineering	Open
127	EN20176881	SHIVAM SINGH	Male	Dr. D. Y. Patil School OF Engineering, Lohegaon, Pune	Computer Engineering	Not Applicable
128	EN20127908	SHIVARKAR PRERANA MAHADEV	Female	Dr. D. Y. Patil School OF Engineering, Lohegaon, Pune	Computer Engineering	OBC
129	EN20158560	SHRUTI RAJ	Female	Dr. D. Y. Patil School OF Engineering, Lohegaon, Pune	Computer Engineering	Open
130	EN20221699	SHRUTI SINHA	Female	Dr. D. Y. Patil School OF Engineering, Lohegaon, Pune	Computer Engineering	Not Applicable
131	EN20129613	SONI KAPIL RAVINDER KUMAR	Male	Dr. D. Y. Patil School OF Engineering, Lohegaon, Pune	Computer Engineering	Open
132	EN20120397	SUJEETH PARTHASARATHI	Male	Dr. D. Y. Patil School OF Engineering, Lohegaon, Pune	Computer Engineering	Open
133	EN20179750	SUVARNA PAVAN GOPAL	Male	Dr. D. Y. Patil School OF Engineering, Lohegaon, Pune	Computer Engineering	Open
134	EN20161269	TAMBOLI LAMIJ AKHTAR	Female	Dr. D. Y. Patil School OF Engineering, Lohegaon, Pune	Computer Engineering	Open
135	EN20213362	THAKKER NIMAI RAKESH	Male	Dr. D. Y. Patil School OF Engineering, Lohegaon, Pune	Computer Engineering	Open
136	EN20137058	THAKUR KOMAL MAHENDRA	Female	Dr. D. Y. Patil School OF Engineering, Lohegaon, Pune	Computer Engineering	Open
137	EN20147468	THORE HARISH ASHOK	Male	Dr. D. Y. Patil School OF Engineering, Lohegaon, Pune	Computer Engineering	Open
138	EN20122365	URDE HRISHIKESH DEVENDRA	Male	Dr. D. Y. Patil School OF Engineering, Lohegaon, Pune	Computer Engineering	NT 1 (NT-B)
139	EN20137623	UTTEKAR VINAY VINOD	Male	Dr. D. Y. Patil School OF Engineering, Lohegaon, Pune	Computer Engineering	Open
140	EN20116619	VARADRAJ VIKAS JADHAV	Male	Dr. D. Y. Patil School OF Engineering, Lohegaon, Pune	Computer Engineering	Open
141	EN20168047	VIRAJ VISHNU CHOPADEV	Male	Dr. D. Y. Patil School OF Engineering, Lohegaon, Pune	Computer Engineering	Open

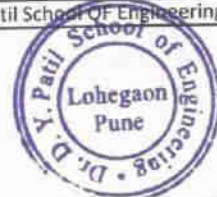

142	EN20141128	VIVEK GUPTA	Male	Dr. D. Y. Patil School Of Engineering, Lohegaon, Pune	Computer Engineering	Open
143	EN20172970	WAIKAR AMAN DATTATRAYA	Male	Dr. D. Y. Patil School Of Engineering, Lohegaon, Pune	Computer Engineering	NT 1 (NT-B)
144	EN20163738	YADAV SAURABH RADHAKISHAN	Male	Dr. D. Y. Patil School Of Engineering, Lohegaon, Pune	Computer Engineering	Open
145	EN20201155	YADAV SWARAJ VASANT	Male	Dr. D. Y. Patil School Of Engineering, Lohegaon, Pune	Computer Engineering	Open
146	EN20138033	YASH KUMAR	Male	Dr. D. Y. Patil School Of Engineering, Lohegaon, Pune	Computer Engineering	Not Applicable
147	EN20174086	ZAMBRE SWARNIL SANJAY	Male	Dr. D. Y. Patil School Of Engineering, Lohegaon, Pune	Computer Engineering	Open
148	EN20202070	ZAMBRE SHRADDHA LAXMAN	Female	Dr. D. Y. Patil School Of Engineering, Lohegaon, Pune	Computer Engineering	Open
149	EN20148055	ARYA NUTAN PURANCHANDRA	Female	Dr. D. Y. Patil School Of Engineering, Lohegaon, Pune	Computer Engineering	Open
150	EN20154457	BHOSALE NETAJI NANDKUMAR	Male	Dr. D. Y. Patil School Of Engineering, Lohegaon, Pune	Computer Engineering	Open
151	EN20168102	BOCHARE VIJAY MOHANRAO	Male	Dr. D. Y. Patil School Of Engineering, Lohegaon, Pune	Computer Engineering	Open
152	EN20203137	KASTURE TANVI VILAS	Female	Dr. D. Y. Patil School Of Engineering, Lohegaon, Pune	Computer Engineering	Open
153	EN20170142	KUNALE ASHWINI SURESH	Female	Dr. D. Y. Patil School Of Engineering, Lohegaon, Pune	Computer Engineering	Open
154	EN20161919	WAYKAR PALLAVI SHIVAJI	Female	Dr. D. Y. Patil School Of Engineering, Lohegaon, Pune	Computer Engineering	Open
155	EN20157571	AMBEKAR PALLAVI ATUL	Female	Dr. D. Y. Patil School Of Engineering, Lohegaon, Pune	Computer Engineering	Open
156	EN20223035	ANSARI ASIM JAHANGIR	Male	Dr. D. Y. Patil School Of Engineering, Lohegaon, Pune	Computer Engineering	Open
157	EN20131978	ASHISH PANDA	Male	Dr. D. Y. Patil School Of Engineering, Lohegaon, Pune	Computer Engineering	Open
158	EN20217110	AWALA KRISHNAPRASAD VENKATESH	Male	Dr. D. Y. Patil School Of Engineering, Lohegaon, Pune	Computer Engineering	Open
159	EN20134814	BONDLA TARUN	Male	Dr. D. Y. Patil School Of Engineering, Lohegaon, Pune	Computer Engineering	Open
160	EN20212147	CHASKAR AVISHKAR BALU	Male	Dr. D. Y. Patil School Of Engineering, Lohegaon, Pune	Computer Engineering	Open
161	EN20136735	DIVYA YUVARAJ SALLUNKE	Female	Dr. D. Y. Patil School Of Engineering, Lohegaon, Pune	Computer Engineering	Open
162	EN20129266	GARGI SANJAY SAROLKAR	Female	Dr. D. Y. Patil School Of Engineering, Lohegaon, Pune	Computer Engineering	Open
163	EN20155227	GHEGADE SHAMBHAWI SHIRISH	Female	Dr. D. Y. Patil School Of Engineering, Lohegaon, Pune	Computer Engineering	Open
164	EN20119644	GIRDE PRANAY SATYAWAN	Male	Dr. D. Y. Patil School Of Engineering, Lohegaon, Pune	Computer Engineering	Open
165	EN20211979	GOVIND CHOUDHARY	Male	Dr. D. Y. Patil School Of Engineering, Lohegaon, Pune	Computer Engineering	Open
166	EN20150316	HIPPARAGI HARDIK BASAVARAJ	Male	Dr. D. Y. Patil School Of Engineering, Lohegaon, Pune	Computer Engineering	Open
167	EN20204273	JADHAV VAIBHAV TATERAO	Male	Dr. D. Y. Patil School Of Engineering, Lohegaon, Pune	Computer Engineering	Open
168	EN20184591	JAGTAO SHRAVANKUMAR DATTATRAY	Male	Dr. D. Y. Patil School Of Engineering, Lohegaon, Pune	Computer Engineering	Open
169	EN20110466	JALGAONKAR HAMID NIVAZ ALI	Male	Dr. D. Y. Patil School Of Engineering, Lohegaon, Pune	Computer Engineering	Open
170	EN20200650	JAYESH SANJIV SATOTE	Male	Dr. D. Y. Patil School Of Engineering, Lohegaon, Pune	Computer Engineering	Open
171	EN20199675	KALBHOR OMKAR DATTATRAY	Male	Dr. D. Y. Patil School Of Engineering, Lohegaon, Pune	Computer Engineering	Open
172	EN20138680	KARMARKAR SHUBHAM SUNIL	Male	Dr. D. Y. Patil School Of Engineering, Lohegaon, Pune	Computer Engineering	Open
173	EN20112661	KHUNE SOHAM RAJESH	Male	Dr. D. Y. Patil School Of Engineering, Lohegaon, Pune	Computer Engineering	Open
174	EN20196309	KORHALE MAYUR VITTHAL	Male	Dr. D. Y. Patil School Of Engineering, Lohegaon, Pune	Computer Engineering	Open
175	EN20219740	KUMAR AMAN	Male	Dr. D. Y. Patil School Of Engineering, Lohegaon, Pune	Computer Engineering	Open
176	EN20207493	MAHE DESHMUKH DIGVIJAYSINH UDAYSI	Male	Dr. D. Y. Patil School Of Engineering, Lohegaon, Pune	Computer Engineering	Open
177	EN20215654	MANISH KUNAR MISHRA	Male	Dr. D. Y. Patil School Of Engineering, Lohegaon, Pune	Computer Engineering	Open
178	EN202006975	PABALKAR VAISHNAVI KIRAN	Female	Dr. D. Y. Patil School Of Engineering, Lohegaon, Pune	Computer Engineering	Open
179	EN20179297	PARATE PIYUSH DEEPAKRAO	Male	Dr. D. Y. Patil School Of Engineering, Lohegaon, Pune	Computer Engineering	Open
180	EN20142978	PATIL SARTHAK SHARADCHANDRA	Male	Dr. D. Y. Patil School Of Engineering, Lohegaon, Pune	Computer Engineering	Open
181	EN20162788	PRINCE SINGH	Male	Dr. D. Y. Patil School Of Engineering, Lohegaon, Pune	Computer Engineering	Open
182	EN20117492	PRIVOTKARSH DWIVEDI	Male	Dr. D. Y. Patil School Of Engineering, Lohegaon, Pune	Computer Engineering	Open
183	EN20153020	PURI ASHUTOSH NARAYAN	Female	Dr. D. Y. Patil School Of Engineering, Lohegaon, Pune	Computer Engineering	Open
184	EN20159821	PURNIMA DHURWEY	Female	Dr. D. Y. Patil School Of Engineering, Lohegaon, Pune	Computer Engineering	Open
185	EN20215589	RAJ RANJAN	Male	Dr. D. Y. Patil School Of Engineering, Lohegaon, Pune	Computer Engineering	Open
186	EN20203969	RAMPURE VISHWESH LINGRAJ	Male	Dr. D. Y. Patil School Of Engineering, Lohegaon, Pune	Computer Engineering	Open
187	EN20124773	RAPATWAR SHANTANU PRADEEP	Male	Dr. D. Y. Patil School Of Engineering, Lohegaon, Pune	Computer Engineering	Open
188	EN20145575	RITUPARNA SAHU	Female	Dr. D. Y. Patil School Of Engineering, Lohegaon, Pune	Computer Engineering	Open
189	EN20123373	ROHIT RANA	Male	Dr. D. Y. Patil School Of Engineering, Lohegaon, Pune	Computer Engineering	Open
190	EN20199274	SAHANE RUTURAJ PRAMOD	Male	Dr. D. Y. Patil School Of Engineering, Lohegaon, Pune	Computer Engineering	Open



191	EN20174312	SHETTY SUYASH HARISH	Male	Dr. D. Y. Patil School OF Engineering, Lohegaon, Pune	Electronics and Telecommunication Engg	Open
192	EN20155253	SHINDE RUTUJA PRAVIN	Female	Dr. D. Y. Patil School OF Engineering, Lohegaon, Pune	Electronics and Telecommunication Engg	OBC
193	EN20198210	SHINDE SNEHA ABASAHEB	Female	Dr. D. Y. Patil School OF Engineering, Lohegaon, Pune	Electronics and Telecommunication Engg	Open
194	EN20139272	SONAL SINGH	Female	Dr. D. Y. Patil School OF Engineering, Lohegaon, Pune	Electronics and Telecommunication Engg	Not Applicable
195	EN20125076	SONWANE ANIKET VILAS	Male	Dr. D. Y. Patil School OF Engineering, Lohegaon, Pune	Electronics and Telecommunication Engg	OBCS
196	EN20130772	SUBODH G DHOKE	Male	Dr. D. Y. Patil School OF Engineering, Lohegaon, Pune	Electronics and Telecommunication Engg	SC
197	EN20203174	SURYAWANSHI MAYURI SATISH	Female	Dr. D. Y. Patil School OF Engineering, Lohegaon, Pune	Electronics and Telecommunication Engg	Open
198	EN20207639	THORAT SAHIL SHIVAJI	Male	Dr. D. Y. Patil School OF Engineering, Lohegaon, Pune	Electronics and Telecommunication Engg	Open
199	EN20115410	VAISHNAVI ASHOK PATIL	Female	Dr. D. Y. Patil School OF Engineering, Lohegaon, Pune	Electronics and Telecommunication Engg	OBC
200	EN20223844	VAISHNAVI RAJKUMAR KALE	Female	Dr. D. Y. Patil School OF Engineering, Lohegaon, Pune	Electronics and Telecommunication Engg	Not Applicable
201	EN20218134	WANKHEDE GAURAV RAJENDRA	Male	Dr. D. Y. Patil School OF Engineering, Lohegaon, Pune	Electronics and Telecommunication Engg	OBC
202	EN20166444	BHERDE RUTUJA MANISH	Female	Dr. D. Y. Patil School OF Engineering, Lohegaon, Pune	Electronics and Telecommunication Engg	OBC
203	EN20208834	CHAVAN AISHWARYA ASHOK	Female	Dr. D. Y. Patil School OF Engineering, Lohegaon, Pune	Electronics and Telecommunication Engg	Open
204	EN20143119	PRAJAKTA PRATAP CHAVAN	Female	Dr. D. Y. Patil School OF Engineering, Lohegaon, Pune	Electronics and Telecommunication Engg	Open
205	EN20156818	BHISE TEJAS VIJAY	Male	Dr. D. Y. Patil School OF Engineering, Lohegaon, Pune	Mechanical Engineering	SC
206	EN20132810	BHOR GANESH VISHWAS	Male	Dr. D. Y. Patil School OF Engineering, Lohegaon, Pune	Mechanical Engineering	OBC
207	EN20223425	BHOSALE TEJAS DATTATRAY	Male	Dr. D. Y. Patil School OF Engineering, Lohegaon, Pune	Mechanical Engineering	Open
208	EN20149715	DAHODWALA HASHIM MOHAMMED	Male	Dr. D. Y. Patil School OF Engineering, Lohegaon, Pune	Mechanical Engineering	Open
209	EN20250418	JADHAV KARAN VIJAY	Male	Dr. D. Y. Patil School OF Engineering, Lohegaon, Pune	Mechanical Engineering	Open
210	EN20178526	MANE ADITI SHIVAJI	Female	Dr. D. Y. Patil School OF Engineering, Lohegaon, Pune	Mechanical Engineering	Open
211	EN20113288	PILLAI SAMSON THOMAS	Male	Dr. D. Y. Patil School OF Engineering, Lohegaon, Pune	Mechanical Engineering	Open
212	EN20119196	SAWANT ABHISHEK RAJESH	Male	Dr. D. Y. Patil School OF Engineering, Lohegaon, Pune	Mechanical Engineering	Open
213	EN20116022	SOLANKE KRUSHNA DHANRAJ	Male	Dr. D. Y. Patil School OF Engineering, Lohegaon, Pune	Mechanical Engineering	Open
214	EN20119743	VRIDHI SACHDEV	Female	Dr. D. Y. Patil School OF Engineering, Lohegaon, Pune	Artificial Intelligence and Data Science	Open
215	EN20201073	ABHAYSINH PADMAKAR LANDGE	Male	Dr. D. Y. Patil School OF Engineering, Lohegaon, Pune	Artificial Intelligence and Data Science	Open
216	EN20217515	ADHAV JAY MOHAN	Male	Dr. D. Y. Patil School OF Engineering, Lohegaon, Pune	Artificial Intelligence and Data Science	SC
217	EN20139357	ADITYA VERMA	Male	Dr. D. Y. Patil School OF Engineering, Lohegaon, Pune	Artificial Intelligence and Data Science	Not Applicable
218	EN20142205	AKASH RAJ	Male	Dr. D. Y. Patil School OF Engineering, Lohegaon, Pune	Artificial Intelligence and Data Science	Not Applicable
219	EN20224620	AMBULE BHUSHAN PRADIP	Male	Dr. D. Y. Patil School OF Engineering, Lohegaon, Pune	Artificial Intelligence and Data Science	Open
220	EN20243729	ARONDEKAR BHARGAV NITIN	Male	Dr. D. Y. Patil School OF Engineering, Lohegaon, Pune	Artificial Intelligence and Data Science	Open
221	EN20205664	BEHAR SANSKRUTI RAJU	Female	Dr. D. Y. Patil School OF Engineering, Lohegaon, Pune	Artificial Intelligence and Data Science	SC
222	EN20161571	BHATODE SAHIL SURESH	Male	Dr. D. Y. Patil School OF Engineering, Lohegaon, Pune	Artificial Intelligence and Data Science	OBC
223	EN20153469	BHOLE TEJAL LILADHAR	Female	Dr. D. Y. Patil School OF Engineering, Lohegaon, Pune	Artificial Intelligence and Data Science	OBC
224	EN20170474	CHANDURKAR YASH PRAVIN	Male	Dr. D. Y. Patil School OF Engineering, Lohegaon, Pune	Artificial Intelligence and Data Science	OBC
225	EN20145129	CHAVAN HARSHAD SHANKAR	Male	Dr. D. Y. Patil School OF Engineering, Lohegaon, Pune	Artificial Intelligence and Data Science	Open
226	EN20199149	CHAVAN PRASAD RAJENDRA	Male	Dr. D. Y. Patil School OF Engineering, Lohegaon, Pune	Artificial Intelligence and Data Science	SC
227	EN20231704	CHAVAN ROHIT DNYANESHWAR	Male	Dr. D. Y. Patil School OF Engineering, Lohegaon, Pune	Artificial Intelligence and Data Science	Open
228	EN20133189	CIVI ABHILASH GOPALKRISHNA	Male	Dr. D. Y. Patil School OF Engineering, Lohegaon, Pune	Artificial Intelligence and Data Science	Open
229	EN20227791	DAREKAR YASH PRAKASH	Male	Dr. D. Y. Patil School OF Engineering, Lohegaon, Pune	Artificial Intelligence and Data Science	Open
230	EN20169863	DEOKAR CHAITANYA RAJESH	Male	Dr. D. Y. Patil School OF Engineering, Lohegaon, Pune	Artificial Intelligence and Data Science	Open
231	EN20218657	DESAI SANJANA PRAVEENKUMAR	Female	Dr. D. Y. Patil School OF Engineering, Lohegaon, Pune	Artificial Intelligence and Data Science	Open
232	EN20207092	DHARMAVAT ARPITA RAJENDRA	Female	Dr. D. Y. Patil School OF Engineering, Lohegaon, Pune	Artificial Intelligence and Data Science	Open
233	EN20209130	DUPARE JYOTI PURUSHOTTAM	Female	Dr. D. Y. Patil School OF Engineering, Lohegaon, Pune	Artificial Intelligence and Data Science	SC
234	EN20135727	GADEKAR MAYUR CHINTAMAN	Male	Dr. D. Y. Patil School OF Engineering, Lohegaon, Pune	Artificial Intelligence and Data Science	OBC
235	EN20121464	GAIKWAD MANALI SANJAY	Female	Dr. D. Y. Patil School OF Engineering, Lohegaon, Pune	Artificial Intelligence and Data Science	Open
236	EN20173021	GAIKWAD SUHANI RAMESH	Female	Dr. D. Y. Patil School OF Engineering, Lohegaon, Pune	Artificial Intelligence and Data Science	Open
237	EN20199847	GAMBHIRE ABHISHEK CHANDRAKANT	Male	Dr. D. Y. Patil School OF Engineering, Lohegaon, Pune	Artificial Intelligence and Data Science	SC
238	EN20122880	GARJE VIRAJ NITIN	Male	Dr. D. Y. Patil School OF Engineering, Lohegaon, Pune	Artificial Intelligence and Data Science	NT 3 (NT-D)
239	EN20147592	GHONGADE SHUBHAM JAGANNATH	Male	Dr. D. Y. Patil School OF Engineering, Lohegaon, Pune	Artificial Intelligence and Data Science	NT 2 (NT-C)



240	EN20135301	GOSAVI MAYUR SANDIP	Male	Dr. D. Y. Patil School OF Engineering, Lohegaon, Pune	Artificial Intelligence and Data Science	NT 1 (NT-B)
241	EN20163157	INAMDAR ARMAN HIMMATSHEB	Male	Dr. D. Y. Patil School OF Engineering, Lohegaon, Pune	Artificial Intelligence and Data Science	Open
242	EN20204243	JADHAV AJINKYA ANNARAO	Male	Dr. D. Y. Patil School OF Engineering, Lohegaon, Pune	Artificial Intelligence and Data Science	Open
243	EN20244131	JADHAV ANKIT LAJARAS	Male	Dr. D. Y. Patil School OF Engineering, Lohegaon, Pune	Artificial Intelligence and Data Science	Open
244	EN20125776	JADHAV SAYALI DNYANESHWAR	Female	Dr. D. Y. Patil School OF Engineering, Lohegaon, Pune	Artificial Intelligence and Data Science	Open
245	EN20225999	JYOTI PRAKASH ROUT	Male	Dr. D. Y. Patil School OF Engineering, Lohegaon, Pune	Artificial Intelligence and Data Science	Not Applicable
246	EN20183538	KOLHE ASHISH MADHUKAR	Male	Dr. D. Y. Patil School OF Engineering, Lohegaon, Pune	Artificial Intelligence and Data Science	OBC
247	EN20231503	KURHE ABHIJEET GORAKSHNATH	Male	Dr. D. Y. Patil School OF Engineering, Lohegaon, Pune	Artificial Intelligence and Data Science	OBC
248	EN20135739	KUSHWAHA RITESH SINGH JANARDAN	Male	Dr. D. Y. Patil School OF Engineering, Lohegaon, Pune	Artificial Intelligence and Data Science	Open
249	EN20166416	LAVANKAR GAURAV PRABHAKAR	Male	Dr. D. Y. Patil School OF Engineering, Lohegaon, Pune	Artificial Intelligence and Data Science	NT 2 (NT-C)
250	EN20198862	LIMBORE YOGESH ARUNLAL	Male	Dr. D. Y. Patil School OF Engineering, Lohegaon, Pune	Artificial Intelligence and Data Science	NT 1 (NT-B)
251	EN20209971	MORE VISHAL KRISHNAJI	Male	Dr. D. Y. Patil School OF Engineering, Lohegaon, Pune	Artificial Intelligence and Data Science	Open
252	EN20122696	PARA SAI SUBHASH	Male	Dr. D. Y. Patil School OF Engineering, Lohegaon, Pune	Artificial Intelligence and Data Science	Not Applicable
253	EN20129733	PATIL NILAMBARI VIJAY	Female	Dr. D. Y. Patil School OF Engineering, Lohegaon, Pune	Artificial Intelligence and Data Science	Open
254	EN20178817	PATIL ONKAR ASHOK	Male	Dr. D. Y. Patil School OF Engineering, Lohegaon, Pune	Artificial Intelligence and Data Science	Open
255	EN20198555	PATIL PRANAY VINOD	Male	Dr. D. Y. Patil School OF Engineering, Lohegaon, Pune	Artificial Intelligence and Data Science	OBC
256	EN20167318	PATIL TUSHAR AMOL	Male	Dr. D. Y. Patil School OF Engineering, Lohegaon, Pune	Artificial Intelligence and Data Science	Open
257	EN20142587	PATIL VISHWAJEET ISHWAR	Male	Dr. D. Y. Patil School OF Engineering, Lohegaon, Pune	Artificial Intelligence and Data Science	Open
258	EN20144756	PRATHAMESH BALWANT PATIL	Male	Dr. D. Y. Patil School OF Engineering, Lohegaon, Pune	Artificial Intelligence and Data Science	Open
259	EN20117975	RACHITA BISHT	Female	Dr. D. Y. Patil School OF Engineering, Lohegaon, Pune	Artificial Intelligence and Data Science	Open
260	EN20198323	RATHOD PANKAJ RAJU	Male	Dr. D. Y. Patil School OF Engineering, Lohegaon, Pune	Artificial Intelligence and Data Science	DT/VJ
261	EN20160673	RAUT SURAJ SUNIL	Male	Dr. D. Y. Patil School OF Engineering, Lohegaon, Pune	Artificial Intelligence and Data Science	OBC
262	EN20124879	ROHOKALE PRATHAMESH YASHWANT	Male	Dr. D. Y. Patil School OF Engineering, Lohegaon, Pune	Artificial Intelligence and Data Science	OBC
263	EN20174900	RUTUJA RAJU BURDE	Female	Dr. D. Y. Patil School OF Engineering, Lohegaon, Pune	Artificial Intelligence and Data Science	Open
264	EN20200425	SAKHARKAR YASH GANESH	Male	Dr. D. Y. Patil School OF Engineering, Lohegaon, Pune	Artificial Intelligence and Data Science	OBC
265	EN20145707	SANKPAL SHRUTIKA SANJAY	Female	Dr. D. Y. Patil School OF Engineering, Lohegaon, Pune	Artificial Intelligence and Data Science	OBC
266	EN20171066	SATHE KUSHAL VILAS RAO	Male	Dr. D. Y. Patil School OF Engineering, Lohegaon, Pune	Artificial Intelligence and Data Science	Not Applicable
267	EN20173283	SHAIKH IMRAN KALAMUDDIN	Male	Dr. D. Y. Patil School OF Engineering, Lohegaon, Pune	Artificial Intelligence and Data Science	Open
268	EN20183249	SHINDE AMEYA SANDIP	Male	Dr. D. Y. Patil School OF Engineering, Lohegaon, Pune	Artificial Intelligence and Data Science	OBC
269	EN20165376	SHINDE PIYUSA DEEPAK	Female	Dr. D. Y. Patil School OF Engineering, Lohegaon, Pune	Artificial Intelligence and Data Science	Open
270	EN20144702	SHREYASH SURESH JADHAV	Male	Dr. D. Y. Patil School OF Engineering, Lohegaon, Pune	Artificial Intelligence and Data Science	Open
271	EN20144734	SHRIGAN MRUNAL MALLIKARJUN	Female	Dr. D. Y. Patil School OF Engineering, Lohegaon, Pune	Artificial Intelligence and Data Science	SBC
272	EN20133980	SINGH ROHITKUMAR HARISHANKAR	Male	Dr. D. Y. Patil School OF Engineering, Lohegaon, Pune	Artificial Intelligence and Data Science	Open
273	EN20209897	SONONE NIKHIL VISHWAJIT	Male	Dr. D. Y. Patil School OF Engineering, Lohegaon, Pune	Artificial Intelligence and Data Science	SBC
274	EN20169573	TAYADE SAKSHI VINOD	Female	Dr. D. Y. Patil School OF Engineering, Lohegaon, Pune	Artificial Intelligence and Data Science	OBC
275	EN20117036	UTKARSHA UMESH DHANE	Female	Dr. D. Y. Patil School OF Engineering, Lohegaon, Pune	Artificial Intelligence and Data Science	Open
276	EN20118928	WAGHCHAURE YASH BHAUSAHEB	Male	Dr. D. Y. Patil School OF Engineering, Lohegaon, Pune	Artificial Intelligence and Data Science	OBC
277	EN20219016	WAGHMARE SHIVCHARAN SURESH	Male	Dr. D. Y. Patil School OF Engineering, Lohegaon, Pune	Artificial Intelligence and Data Science	SC
278	EN20199916	ZADE PRATHMESH GANESH	Male	Dr. D. Y. Patil School OF Engineering, Lohegaon, Pune	Artificial Intelligence and Data Science	OBC
279	EN20123819	KITUKALE PRADHUMNA RAVINDRA	Male	Dr. D. Y. Patil School OF Engineering, Lohegaon, Pune	Artificial Intelligence and Data Science	OBC
280	EN20130804	PATIL VIVEK ARUN	Male	Dr. D. Y. Patil School OF Engineering, Lohegaon, Pune	Artificial Intelligence and Data Science	OBC

PG

281	20031101ME4	Arati Dilip Kamble	Female	Dr. D. Y. Patil School OF Engineering, Lohegaon, Pune	Computer Engineering	SC
282	20011101ME6	Pavan prakash Chipade	Male	Dr. D. Y. Patil School OF Engineering, Lohegaon, Pune	Mechanical Engineering	MAH / OPEN
283	20011101ME8	AKSHAY RAMCHANDRA MANE	Male	Dr. D. Y. Patil School OF Engineering, Lohegaon, Pune	Mechanical Engineering	MAH / OPEN



284	21051101ME7	YOGESH LAXMAN BHOI	Male	Dr. D. Y. Patil School OF Engineering, Lohegaon, Pune	Mechanical Engineering	VJNT / SBC / ST
285	21111101ME5	DEEPAK P NAIR	Male	Dr. D. Y. Patil School OF Engineering, Lohegaon, Pune	Mechanical Engineering	OTHER STATE
286	20011101ME9	MAYANK BHASKAR	Male	Dr. D. Y. Patil School OF Engineering, Lohegaon, Pune	Electronics and Telecommunication Engg	MAH / OPEN

  
 Mr. Gorakhnath Deshmukh  
 Registrar

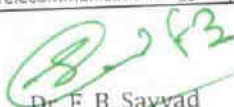

  
 Dr. F. B. Sayyad  
 Principal  
**Principal**  
 Dr. D. Y. Patil School of Engineering  
 Lohegaon, Pune.

# All India Council for Technical Education

(A Statutory body under Ministry of HRD, Govt. of India)

Nelson Mandela Marg, Vasant Kunj, New Delhi-110070 Website: [www.aicte-india.org](http://www.aicte-india.org)



## APPROVAL PROCESS 2020-21

### Extension of Approval (EoA)

F.No. Western/1-7014716436/2020/EOA

Date: 15-Jun-2020

To,

The Secretary,  
Tech. & Higher Education Deptt.  
Govt. of Maharashtra, Mantralaya,  
Annexe Building, Mumbai-400032

**Sub: Extension of Approval for the Academic Year 2020-21**

Ref: Application of the Institution for Extension of Approval for the Academic Year 2020-21

Sir/Madam,

In terms of the provisions under the All India Council for Technical Education (Grant of Approvals for Technical Institutions) Regulations 2020 notified by the Council vide notification number F.No. AB/AICTE/REG/2020 dated 4<sup>th</sup> February 2020 and norms standards, procedures and conditions prescribed by the Council from time to time, I am directed to convey the approval to

Permanent Id	1-3847411	Application Id	1-7014716436
Name of the Institute	DR. D.Y. PATIL GROUP OF INSTITUTIONS (TECHNICAL CAMPUS)	Name of the Society/Trust	DR. D. Y. PATIL EDUCATIONAL ENTERPRISES CHARITABLE TRUST
Institute Address	DR. D. Y. PATIL KNOWLEDGE CITY, S. NO. 136, CHARHOLI (BK), VIA LOHEGAON, TAL.- HAVELI, PUNE, PUNE, Maharashtra, 412105	Society/Trust Address	DR. D. Y. PATIL KNOWLEDGE CITY, S.N. 136, CHARHOLI (BK) VIA LOHEGAON, PUNE, PUNE, PUNE, M aharashtra, 412105
Institute Type	Private-Self Financing	Region	Western

**To conduct following Courses with the Intake indicated below for the Academic Year 2020-21**

Program	Level	Course	Affiliating Body (University /Body)	Intake Approved for 2019-20	Intake Approved for 2020-21	NRI Approval Status	PIO / FN / Gulf quota/ OCI/ Approval Status
ENGINEERING AND TECHNOLOGY	UNDER GRADUATE	CIVIL ENGINEERING	University of Pune, Pune	60	60	NA	NA
ENGINEERING AND TECHNOLOGY	UNDER GRADUATE	COMPUTER ENGINEERING	University of Pune, Pune	120	120	NA	NA
ENGINEERING AND TECHNOLOGY	UNDER GRADUATE	ELECTRONICS AND TELECOMMUNICATIONS ENGINEERING	University of Pune, Pune	60	60	NA	NA



ENGINEERING AND TECHNOLOGY	POST GRADUATE	ELECTRONICS AND TELECOMMUNICATIONS ENGINEERING	University of Pune, Pune	24	24	NA	NA
ENGINEERING AND TECHNOLOGY	POST GRADUATE	MECHANICAL ENGINEERING	University of Pune, Pune	24	24	NA	NA
ENGINEERING AND TECHNOLOGY	DIPLOMA	MECHANICAL ENGINEERING	Maharashtra State Board of Technical Education, Mumbai	120	120	NA	NA
ENGINEERING AND TECHNOLOGY	DIPLOMA	COMPUTER ENGINEERING	Maharashtra State Board of Technical Education, Mumbai	60	60	NA	NA
ENGINEERING AND TECHNOLOGY	UNDER GRADUATE	MECHANICAL ENGINEERING	University of Pune, Pune	180	120	NA	NA
ENGINEERING AND TECHNOLOGY	POST GRADUATE	COMPUTER ENGINEERING	University of Pune, Pune	24	24	NA	NA
ENGINEERING AND TECHNOLOGY	UNDER GRADUATE	ARTIFICIAL INTELLIGENCE AND DATA SCIENCE	Savitribai Phule Pune University	0	60##\$\$	NA	NA

## Approved New Course(s)

\$\$ Course(s) should be offered in Emerging Area

It is mandatory to comply with all the essential requirements as given in APH 2020-21 (Appendix 6)

### Important Instructions

1. The State Government/ UT/ Directorate of Technical Education/ Directorate of Medical Education shall ensure that 10% of reservation for Economically Weaker Section (EWS) as per the reservation policy for admission, operational from the Academic year 2020-21 is implemented without affecting the reservation percentages of SC/ ST/ OBC/ General. However, this would not be applicable in the case of Minority Institutions referred to the Clause (1) of Article 30 of Constitution of India. Such Institution shall be permitted to increase in annual permitted strength over a maximum period of two years beginning with the Academic Year 2020-21
2. The Institution offering courses earlier in the Regular Shift, First Shift, Second Shift/Part Time now amalgamated as total intake shall have to fulfil all facilities such as Infrastructure, Faculty and other requirements as per the norms specified in the Approval Process Handbook 2020-21 for the Total Approved Intake. Further, the Institutions Deemed to be Universities/ Institutions having Accreditation/ Autonomy status shall have to maintain the Faculty: Student ratio as specified in the Approval Process Handbook. All such Institutions/ Universities shall have to create the necessary Faculty, Infrastructure and other facilities WITHIN 2 YEARS to fulfil the norms based on the Affidavit submitted to AICTE.





3. In case of any differences in content in this Computer generated Extension of Approval Letter, the content/information as approved by the Executive Council / General Council as available on the record of AICTE shall be final and binding.
4. Strict compliance of Anti-Ragging Regulation; - Approval is subject to strict compliance of provisions made in AICTE Regulation notified vide F. No. 373/Legal/AICTE/2009 dated July 1, 2009 for Prevention and Prohibition of Ragging in Technical Institutions. In case Institution fails to take adequate steps to Prevent Ragging or fails to act in accordance with AICTE Regulation or fails to punish perpetrators or incidents of Ragging, it will be liable to take any action as defined under clause 9(4) of the said Regulation.

**Prof.Rajive Kumar**  
Member Secretary, AICTE

Copy to:

1. **The Director Of Technical Education\*\***, Maharashtra
2. **The Registrar\*\***,  
University Of Pune, Pune
3. **The Principal / Director**,  
DR. DY PATIL GROUP OF INSTITUTIONS (TECHNICAL CAMPUS)  
Dr. D. Y. Patil Knowledge City, S. No. 136, Charholi (Bk),  
Via Lohegaon, Tal.- Haveli,  
Pune,Pune,  
Maharashtra,412105
4. **The Secretary / Chairman**,  
DR. D. Y. PATIL KNOWLEDGE CITY,S.N. 136,CHARHOLI(BK) VIA LOHEGAON,PUNE  
PUNE,PUNE  
Maharashtra,412105
5. **The Regional Officer**,  
All India Council for Technical Education  
Industrial Assurance Building  
2nd Floor, Nariman Road  
Mumbai - 400 020, Maharashtra
6. **Guard File(AICTE)**

Note: Validity of the Course details may be verified at <http://www.aicte-india.org/>

\*\* Individual Approval letter copy will not be communicated through Post/Email. However, consolidated list of Approved Institutions(bulk) will be shared through official Email Address to the concerned Authorities mentioned above.

  
**Principal**  
Dr. D. Y. Patil School of Engineering  
Lohegaon, Pune





"Empowerment through quality technical education"  
Dr. D. Y. Patil Educational Enterprises Charitable Trust's

**Ajeenkya D Y Patil Group of Institution's Technical Campus**  
**Dr D Y PATIL SCHOOL OF ENGINEERING**

(Approved by AICTE, New Delhi Recognized by Govt. of Maharashtra, Affiliated to Savitribai Phule Pune University)  
AISHE Code: C-46648 DTE Code: EN6732 SPPU PUN Code: CEGP015720  
(Accredited by NAAC)

A.Y. 2020-21

**Program wise list of admitted students**

(Criteria 2.1.1)

UG/PG	Program Name	FE	SE	TE	BE	Total
UG	Computer Engg.	136	185	139	170	630
	Mechanical Engg.	09	154	230	211	604
	Civil Engg.	18	101	57	61	237
	E&TC Engg	50	56	53	64	223
	AI&DS Engg.	67	-	-	-	67
PG	Computer Engg.	01	03	NA	NA	04
	Mechanical Engg.	04	20	NA	NA	24
	E&TC Engg	01	05	NA	NA	06
Total						1795

  
Dr. F. B. Sayyad

Principal



Enclosed: List of Students.

2.1 Number of students during the year (2020-21)

Sr. No	Year of enrollment	Name Of The Students	Student enrollment number	Date of enrolment	Branch
UG					
1	2020.21	Rohit Kumar Jagadale	20011011BE364	27/01/2021	FE Comp SEM I
2	2020.21	Dnyaneshwar Ganesh Jadhav	20011011BE494	29/01/2021	FE Comp SEM I
3	2020.21	Priya Prakash	20011011BE214	14/01/2021	FE Comp SEM I
4	2020.21	Shital Nagesh Kadam	20011011BE219	14/01/2021	FE Comp SEM I
5	2020.21	Sahil Santosh Timbole	20011011BE223	14/01/2021	FE Comp SEM I
6	2020.21	Nutan Puranchandra Arya	20011011BE232	15/01/2021	FE Comp SEM I
7	2020.21	Shivani Shankar Sawant	20011011BE255	2019-2020	FE Comp SEM I
8	2020.21	Ashlesha Vijay Katore	20011011BE286	2019-2020	FE Comp SEM I
9	2020.21	Rohit Rajendra Deshmukh	20011011BE289	2019-2020	FE Comp SEM I
10	2020.21	Suraj Santosh Jadhav	20011011BE303	16/01/2021	FE Comp SEM I
11	2020.21	Ashwini Suresh Kunale	20011011BE306	2019-2020	FE Comp SEM I
12	2020.21	Vivek Gupta	20011011BE313	16/01/2021	FE Comp SEM I
13	2020.21	Pavan Gopal Suvarna	20011011BE331	16/01/2021	FE Comp SEM I
14	2020.21	Kaustubh Kanhaiya Jha	20011011BE344	27/01/2021	FE Comp SEM I
15	2020.21	Sujeeth Parthasarathi	20011011BE349	27/01/2021	FE Comp SEM I
16	2020.21	Shraddha Laxman Zaware	20011011BE356	27/01/2021	FE Comp SEM I
17	2020.21	Dakshata Sunil Mane	20011011BE357	27/01/2021	FE Comp SEM I
18	2020.21	Sushant Liladhar Patwe	20011011BE360	27/01/2021	FE Comp SEM I
19	2020.21	Ayush Sharma	20011011BE361	2019-2020	FE Comp SEM I
20	2020.21	Chaithanya H	20011011BE368	2019-2020	FE Comp SEM I
21	2020.21	Kapil Ravinder Kumar Soni	20011011BE375	27/01/2021	FE Comp SEM I
22	2020.21	Devang Dinesh Mathur	20011011BE383	27/01/2021	FE Comp SEM I
23	2020.21	Yukta Shrikant Lokwani	20011011BE385	28/01/2021	FE Comp SEM I
24	2020.21	Vijay Mohanrao Bochare	20011011BE405	2019-2020	FE Comp SEM I
25	2020.21	Sadiya Salim Sayyed	20011011BE420	28/01/2021	FE Comp SEM I
26	2020.21	Shivam Singh	20011011BE423	28/01/2021	FE Comp SEM I
27	2020.21	Omkar Subhash Mule	20011011BE425	28/01/2021	FE Comp SEM I
28	2020.21	Mehlam Parvez Ali	20011011BE430	28/01/2021	FE Comp SEM I
29	2020.21	Mukund Pathak	20011011BE436	28/01/2021	FE Comp SEM I
30	2020.21	Arunima Janardhanan Chakkithara	20011011BE448	28/01/2021	FE Comp SEM I
31	2020.21	Sudarshan Pratap Jadhav	20011011BE451	28/01/2021	FE Comp SEM I
32	2020.21	Sadaf Qaish	20011011BE458	29/01/2021	FE Comp SEM I
33	2020.21	Vaidehi Vivek Mujumdar	20011011BE460	29/01/2021	FE Comp SEM I
34	2020.21	Rutuja Ashish Pimpalkhare	20011011BE477	29/01/2021	FE Comp SEM I
35	2020.21	Pradnya Dhananjay Netke	20011011BE491	29/01/2021	FE Comp SEM I
36	2020.21	Vaishnavi Sanjay Kadam	20011011BE495	29/01/2021	FE Comp SEM I
37	2020.21	Netaji Nandkumar Bhosale	20011011BE503	2019-2020	FE Comp SEM I
38	2020.21	Pranisha Pradeep Mirkhalkar	20011011BE513	29/01/2021	FE Comp SEM I
39	2020.21	Sejal Sunil Gupta	20011011BE514	29/01/2021	FE Comp SEM I
40	2020.21	Lamij Akhtar Tamboli	20011011BE529	29/01/2021	FE Comp SEM I
41	2020.21	Mansi Pradip Kotkar	20011011BE548	30/01/2021	FE Comp SEM I
42	2020.21	Aaditya Agarwal	20011011BE572	30/01/2021	FE Comp SEM I



43	2020.21	Chandni Shivbaran Yadav	20011011BE573	30/01/2021	FE Comp SEM I
44	2020.21	Priyanshi Shailendra Sugandhi	20011011BE597	02-01-2021	FE Comp SEM I
45	2020.21	Vinay Vinod Uttekar	20011011BE602	02-01-2021	FE Comp SEM I
46	2020.21	Sunil Nathuram Jungid	20011011BE603	29/01/2021	FE Comp SEM I
47	2020.21	Dakshata Negi	20011011BE609	29/01/2021	FE Comp SEM I
48	2020.21	Aditya Singh	20011011BE612	02-03-2021	FE Comp SEM I
49	2020.21	Viraj Vishnu Chopade	20011011BE613	29/01/2021	FE Comp SEM I
50	2020.21	Shailesh Kumar Yadav	20011011BE616	29/01/2021	FE Comp SEM I
51	2020.21	Manas Sanjay Shedge	20011011BE628	29/01/2021	FE Comp SEM I
52	2020.21	Rajat Acharjee	20011011BE629	02-05-2021	FE Comp SEM I
53	2020.21	Shruti Sinha	20011011BE633	02-05-2021	FE Comp SEM I
54	2020.21	Anand Arun Sonwane	20011011BE635	29/01/2021	FE Comp SEM I
55	2020.21	Anshul Jawa	20011011BE636	02-08-2021	FE Comp SEM I
56	2020.21	Anuragkumar Munna Ojha	20011011BE637	02-08-2021	FE Comp SEM I
57	2020.21	Chetan Shambhoo Kharwar	20011011BE639	02-08-2021	FE Comp SEM I
58	2020.21	Divyansh Singh Sikarwar	20011011BE640	29/01/2021	FE Comp SEM I
59	2020.21	Gopal Kumar Thakur	20011011BE641	2019-2020	FE Comp SEM I
60	2020.21	Yash Dattatray Khaire	20011011BE644	02-08-2021	FE Comp SEM I
61	2020.21	Nitika Raj	20011011BE646	2019-2020	FE Comp SEM I
62	2020.21	Dev Manojbhai Patel	20011011BE647	02-08-2021	FE Comp SEM I
63	2020.21	Prathamesh Rangnath Raut	20011011BE652	02-08-2021	FE Comp SEM I
64	2020.21	Ritik Sanjay Seth	20011011BE653	02-08-2021	FE Comp SEM I
65	2020.21	Rohit Rai	20011011BE654	29/01/2021	FE Comp SEM I
66	2020.21	Saurabh Sukdev Waman	20011011BE655	2019-2020	FE Comp SEM I
67	2020.21	Shaikh Yousuf Mohammad Kaleem	20011011BE656	2019-2020	FE Comp SEM I
68	2020.21	Shruti Arvind Raj	20011011BE657	2019-2020	FE Comp SEM I
69	2020.21	Nimai Rakesh Thakkar	20011011BE658	2019-2020	FE Comp SEM I
70	2020.21	Komal Mahendra Thakur	20011011BE659	02-08-2021	FE Comp SEM I
71	2020.21	Swaraj Vasant Yadav	20011011BE660	02-08-2021	FE Comp SEM I
72	2020.21	Atul Naresh More	20011031BE71	2019-2020	FE Comp SEM I
73	2020.21	Aakash Manish Ayachit	20011041BE53	27/01/2021	FE Comp SEM I
74	2020.21	Pallavi Shivaji Waykar	200111011BE353	27/01/2021	FE Comp SEM I
75	2020.21	Harish Ashok Thore	200111011BE366	27/01/2021	FE Comp SEM I
76	2020.21	Pranavraj Lalasaheb Pawar	200111011BE379	27/01/2021	FE Comp SEM I
77	2020.21	Varadraj Vikas Jadhav	200111011BE518	29/01/2021	FE Comp SEM I
78	2020.21	Saurabh Radhakishan Yadav	200111011BE541	27/01/2021	FE Comp SEM I
79	2020.21	Navale Harshvardhan Sunil	20021011BE218	27/01/2021	FE Comp SEM I
80	2020.21	Dhiraj Pandurang Kumbhar	20021011BE233	15/01/2021	FE Comp SEM I
81	2020.21	Sanskriti Satish Khedkar	20021011BE238	27/01/2021	FE Comp SEM I
82	2020.21	Apeksha Ramesh Meharkar	20021011BE247	15/01/2021	FE Comp SEM I
83	2020.21	Siddhant Ajit Hase	20021011BE276	27/01/2021	FE Comp SEM I
84	2020.21	Vedraj Hemant Belokar	20021011BE287	16/01/2021	FE Comp SEM I
85	2020.21	Swapnil Sanjay Zambre	20021011BE296	27/01/2021	FE Comp SEM I
86	2020.21	Kshiti Hemkant Patil	20021011BE328	27/01/2021	FE Comp SEM I
87	2020.21	Tanvi Vilas Kasture	20021011BE352	27/01/2021	FE Comp SEM I
88	2020.21	Ashishkarche Vikas Karche	20021011BE355	27/01/2021	FE Comp SEM I
89	2020.21	Harsh Anand Naikwade	20021011BE359	27/01/2021	FE Comp SEM I



90	2020.21	Vedant Shashikant Gaikwad	20021011BE367	27/01/2021	FE Comp SEM I
91	2020.21	Bhargav Nitin Balinge	20021011BE373	27/01/2021	FE Comp SEM I
92	2020.21	Saurabh Rakesh Bhamare	20021011BE386	27/01/2021	FE Comp SEM I
93	2020.21	Sarthak Santosh Bhosale	20021011BE392	28/01/2021	FE Comp SEM I
94	2020.21	Kaustubh Rajendra Dhotre	20021011BE408	27/01/2021	FE Comp SEM I
95	2020.21	Pratik Ashok Katore	20021011BE410	28/01/2021	FE Comp SEM I
96	2020.21	Ajinkya Sunil Magar	20021011BE517	29/01/2021	FE Comp SEM I
97	2020.21	Gargi Rajesh Balsaraf	20021011BE541	30/01/2021	FE Comp SEM I
98	2020.21	Sakshi Suhās Bhujbal	20021011BE551	30/01/2021	FE Comp SEM I
99	2020.21	Rushikesh Yananath Dhasal	20021011BE553	27/01/2021	FE Comp SEM I
100	2020.21	Prerana Mahadev Shivarkar	20021011BE567	30/01/2021	FE Comp SEM I
101	2020.21	Kartikey Purushottam Patil	20021011BE595	02-01-2021	FE Comp SEM I
102	2020.21	Gauri Kishor Patil	20021011BE596	27/01/2021	FE Comp SEM I
103	2020.21	Yash Kumar	20021011BE618	02-03-2021	FE Comp SEM I
104	2020.21	Sanket Bipin Abhang	20021011BE623	27/01/2021	FE Comp SEM I
105	2020.21	Yash Sunil Bagul	20031011BE234	15/01/2021	FE Comp SEM I
106	2020.21	Tanmay Vinod Gaikwad	20031011BE273	15/01/2021	FE Comp SEM I
107	2020.21	Niyati Chandramani Wankhede	20031011BE278	15/01/2021	FE Comp SEM I
108	2020.21	Ratndeeep Vijaykumar Paithane	20031011BE346	27/01/2021	FE Comp SEM I
109	2020.21	Rutuja Mahendra Kamble	20031011BE358	27/01/2021	FE Comp SEM I
110	2020.21	Samrudha Ganesh Bhalerao	20031011BE370	27/01/2021	FE Comp SEM I
111	2020.21	Aaditya Bandu Godham	20031011BE399	28/01/2021	FE Comp SEM I
112	2020.21	Anurag Sanjay Shende	20031011BE434	28/01/2021	FE Comp SEM I
113	2020.21	Rushikesh Shashikant Rajguru	20031011BE446	2019-2020	FE Comp SEM I
114	2020.21	Sanskriti Vijay Shelar	20031011BE490	29/01/2021	FE Comp SEM I
115	2020.21	Samruddhi Rajesh Jadhav	20031011BE588	30/01/2021	FE Comp SEM I
116	2020.21	Milind Mohanrao Gaikwad	20031011BE606	02-02-2021	FE Comp SEM I
117	2020.21	Pratik Laxman Khade	20031021BE178	27/01/2021	FE Comp SEM I
118	2020.21	Aman Dattatraya Waikar	20051011BE265	27/01/2021	FE Comp SEM I
119	2020.21	Abhishek Uday Salokhe	20051011BE337	20/01/2021	FE Comp SEM I
120	2020.21	Yash Rewaram Nanhe	20051011BE456	27/01/2021	FE Comp SEM I
121	2020.21	Mayur Ekanath Kadam	20051011BE519	29/01/2021	FE Comp SEM I
122	2020.21	Gayatri Santosh Shinde	20061011BE224	14/01/2021	FE Comp SEM I
123	2020.21	Athrav Laxman Metkari	20061011BE412	28/01/2021	FE Comp SEM I
124	2020.21	Pranjali Jaganath Gavli	20061011BE424	28/01/2021	FE Comp SEM I
125	2020.21	Sakshi Ramesh Gorlawar	20061011BE546	27/01/2021	FE Comp SEM I
126	2020.21	Hrishikesh Devendra Urde	20061011BE614	27/01/2021	FE Comp SEM I
127	2020.21	Pratik Chandrabhan Nawale	20071011BE262	15/01/2021	FE Comp SEM I
128	2020.21	Mahesh Sanjay Hajare	20081011BE428	27/01/2021	FE Comp SEM I
129	2020.21	Anil Suresh Rathod	20091011BE387	27/01/2021	FE Comp SEM I
130	2020.21	Ishan Pandita	21011011BE211	01-05-2021	FE Comp SEM I
131	2020.21	Yash Prakash Shinde	21011011BE398	28/01/2021	FE Comp SEM I
132	2020.21	Sairaj Sunil Kale	210111011BE549	2019-2020	FE Comp SEM I
133	2020.21	Anshul Sachin Mehetre	21021011BE411	27/01/2021	FE Comp SEM I
134	2020.21	Tejas Krishna Golait	21031011BE346	27/01/2021	FE Comp SEM I
135	2020.21	Khushi Amit Jamlekar	21031011BE413	28/01/2021	FE Comp SEM I
136	2020.21	Samiksha Mohan Chavan	21051011BE557	2019-2020	FE Comp SEM I



137	2020.21	Aditi Shivaji Mane	20011011BE266	15/01/2021	FE Mech SEM I
138	2020.21	Hashim Mohammed Dahodwala	20011011BE369	2019-2020	FE Mech SEM I
139	2020.21	Tejas Dattatray Bhosale	20011011BE378	27/01/2021	FE Mech SEM I
140	2020.21	Krushna Dhamraj Solanke	20011011BE475	29/01/2021	FE Mech SEM I
141	2020.21	Samson Thomas Pillai	20011011BE577	2019-2020	FE Mech SEM I
142	2020.21	Karan Vijay Jadhav	20011011BE642	02-08-2021	FE Mech SEM I
143	2020.21	Ganesh Vishwas Bhor	20021011BE339	2019-2020	FE Mech SEM I
144	2020.21	Tejas Vijay Bhise	20031011BE461	2019-2020	FE Mech SEM I
145	2020.21	Abhishek Rajesh Sawant	2101011BE566	2019-2020	FE Mech SEM I
146	2020.21	Ayush Amar Madikunt	20011011BE222	2019-2020	FE Civil SEM I
147	2020.21	Shivraj Nivrutti Shirke	20011011BE264	15/01/2021	FE Civil SEM I
148	2020.21	Junaid Yakub Shaikh	20011011BE271	15/01/2021	FE Civil SEM I
149	2020.21	Ashutosh Satish Kangude	20011011BE316	16/01/2021	FE Civil SEM I
150	2020.21	Aryan Narendrakumar Mettalu	20011011BE624	02-04-2021	FE Civil SEM I
151	2020.21	Chaitanya Pradeep Pawar	20011011BE649	2019-2020	FE Civil SEM I
152	2020.21	Rameshwar Prakash Chavhan	20011021BE181	29/01/2021	FE Civil SEM I
153	2020.21	Mihir Bharat Labdhe	20021011BE235	15/01/2021	FE Civil SEM I
154	2020.21	Harshal Ramakant Korde	20021011BE283	15/01/2021	FE Civil SEM I
155	2020.21	Mayuri Dattatraya Dongare	20021011BE342	20/01/2021	FE Civil SEM I
156	2020.21	Atharva Shailendra Kapale	20021011BE377	27/01/2021	FE Civil SEM I
157	2020.21	Pranit Vinay Kamble	20031011BE258	15/01/2021	FE Civil SEM I
158	2020.21	Vishal Suresh Chavan	20051011BE278	15/01/2021	FE Civil SEM I
159	2020.21	Bhushan Rajendra Jadhav	20051011BE341	20/01/2021	FE Civil SEM I
160	2020.21	Rohan Kalyan Bhandare	20061011BE285	16/01/2021	FE Civil SEM I
161	2020.21	Rushikesh Rameshwar Borse	20061011BE543	30/01/2021	FE Civil SEM I
162	2020.21	Pawanraj Maruti Khamkar	21011011BE419	2019-2020	FE Civil SEM I
163	2020.21	Raj Ashok Sonone	21021011BE390	2019-2020	FE Civil SEM I
164	2020.21	Krishnaprasad Venkatesh Awala	20011011BE216	2019-2020	FE ENTC SEM I
165	2020.21	Omkar Dattatray Kalbhor	20011011BE229	2019-2020	FE ENTC SEM I
166	2020.21	Shravankumar Dattatray Jagtap	20011011BE254	15/01/2021	FE ENTC SEM I
167	2020.21	Sahil Shivaji Thorat	20011011BE322	16/01/2021	FE ENTC SEM I
168	2020.21	Hardik Basavaraj Hipparagi	20011011BE343	27/01/2021	FE ENTC SEM I
169	2020.21	Prajakta Pratap Chavan	20011011BE362	2019-2020	FE ENTC SEM I
170	2020.21	Hamid Niyaz Ali Jalgaonkar	20011011BE374	2019-2020	FE ENTC SEM I
171	2020.21	Ashish Vishnu Panda	20011011BE395	28/01/2021	FE ENTC SEM I
172	2020.21	Mayuri Satish Suryawanshi	20011011BE407	28/01/2021	FE ENTC SEM I
173	2020.21	Gargi Sanjay Sarolkar	20011011BE434		FE ENTC SEM I
174	2020.21	Rituparna Sahu	20011011BE469	2019-2020	FE ENTC SEM I
175	2020.21	Mayur Vitthal Korhale	20011011BE489	29/01/2021	FE ENTC SEM I
176	2020.21	Rohit Rana	20011011BE498	2019-2020	FE ENTC SEM I
177	2020.21	Manish Kumar Mishra	20011011BE516	29/01/2021	FE ENTC SEM I
178	2020.21	Aishwarya Ashok Chavan	20011011BE528		FE ENTC SEM I
179	2020.21	Avishkar Balu Chaskar	20011011BE545	2019-2020	FE ENTC SEM I
180	2020.21	Sneha Abasaheb Shinde	20011011BE580	30/01/2021	FE ENTC SEM I
181	2020.21	Sonal Singh	20011011BE598	02-01-2021	FE ENTC SEM I
182	2020.21	Govind Choudhary	20011011BE605	02-02-2021	FE ENTC SEM I
183	2020.21	Prince Singh	20011011BE610	2019-2020	FE ENTC SEM I



184	2020.21	Suyash Harish Shetty	20011011BE611	2019-2020	FE ENTC SEM I
185	2020.21	Shubham Sunil Karmarkar	20011011BE619	02-03-2021	FE ENTC SEM I
186	2020.21	Vaibhav Taterao Jadhav	20011011BE630	02-05-2021	FE ENTC SEM I
187	2020.21	Purnima Dhurwey	20011011BE631	2019-2020	FE ENTC SEM I
188	2020.21	Shambhavi Shirish Ghegade	20011011BE634	02-08-2021	FE ENTC SEM I
189	2020.21	Kumar Aman Sanjay Kumar Pathak	20011011BE645	02-08-2021	FE ENTC SEM I
190	2020.21	Priyotkarsh Dwivedi	20011011BE650	02-08-2021	FE ENTC SEM I
191	2020.21	Raj Hare Ram Ranjan	20011011BE651	02-08-2021	FE ENTC SEM I
192	2020.21	Tarun Bondla	20011021	2019-2020	FE ENTC SEM I
193	2020.21	Pranay Satyawar Girde	20021011BE236	15/01/2021	FE ENTC SEM I
194	2020.21	Rutuja Manish Bherde	20021011BE239		FE ENTC SEM I
195	2020.21	Vaishnavi Ashok Patil	20021011BE261	2019-2020	FE ENTC SEM I
196	2020.21	Rutuja Pravin Shinde	20021011BE294	16/01/2021	FE ENTC SEM I
197	2020.21	Soham Rajesh Khune	20021011BE354	27/01/2021	FE ENTC SEM I
198	2020.21	Asim Jahangir Ansari	20021011BE380	27/01/2021	FE ENTC SEM I
199	2020.21	Sarthak Sharadchandra Patil	20021011BE396	28/01/2021	FE ENTC SEM I
200	2020.21	Gaurav Ranjendra Wankhede	20021011BE401	2019-2020	FE ENTC SEM I
201	2020.21	Shantanu Pradeep Rapatwar	20021011BE458	29/01/2021	FE ENTC SEM I
202	2020.21	Vaishnavi Kiran Pabalkar	20021011BE462	29/01/2021	FE ENTC SEM I
203	2020.21	Aniket Vilas Sonwane	20021011BE592	30/01/2021	FE ENTC SEM I
204	2020.21	Vishwesh Lingraj Rampure	20021011BE593	30/01/2021	FE ENTC SEM I
205	2020.21	Divya Yuvaraj Salunke	20021011BE601	2019-2020	FE ENTC SEM I
206	2020.21	Vaishnavi Rajkumar Kale	20021011BE627	02-04-2021	FE ENTC SEM I
207	2020.21	Subodh Gajanan Dhoke	20031011BE394	2019-2020	FE ENTC SEM I
208	2020.21	Ashutosh Narayan Puri	20051011BE370	2019-2020	FE ENTC SEM I
209	2020.21	Jayesh Sanjiv Satote	20051011BE452	29/01/2021	FE ENTC SEM I
210	2020.21	Piyush Deepakrao Parate	20081011BE540	2019-2020	FE ENTC SEM I
211	2020.21	Digvijaysinh Udaysinh Mane Deshmukh	21011011BE393	2019-2020	FE ENTC SEM I
212	2020.21	Ruturaj Pramod Sahane	21011011BE396	28/01/2021	FE ENTC SEM I
213	2020.21	Atharva Atul Ambekar	21021011BE447	2019-2020	FE ENTC SEM I
214	2020.21	Utkarsha Umesh Dhane	20011011BE213	14/01/2021	FE AI&DS SEM I
215	2020.21	Vridhi Ritesh Sachdev	20011011BE228	14/01/2021	FE AI&DS SEM I
216	2020.21	Abhaysinh Padmakar Landge	20011011BE231	2019-2020	FE AI&DS SEM I
217	2020.21	Kushal Vilasrao Sathe	20011011BE239	2019-2020	FE AI&DS SEM I
218	2020.21	Rachita Bisht	20011011BE243	15/01/2021	FE AI&DS SEM I
219	2020.21	Sanjana Praveenkumar Desai	20011011BE250	15/01/2021	FE AI&DS SEM I
220	2020.21	Rohit Harishankar Singh	20011011BE259	15/01/2021	FE AI&DS SEM I
221	2020.21	Yash Prakash Darekar	20011011BE297	16/01/2021	FE AI&DS SEM I
222	2020.21	Prathamesh Balwant Patil	20011011BE301	2019-2020	FE AI&DS SEM I
223	2020.21	Ankit Lajaras Jadhav	20011011BE315	2019-2020	FE AI&DS SEM I
224	2020.21	Sayali Dnyaneshwar Jadhav	20011011BE327	16/01/2021	FE AI&DS SEM I
225	2020.21	Arpita Rajendra Dharmavat	20011011BE333	16/01/2021	FE AI&DS SEM I
226	2020.21	Abhilash Gopalkrishna Civi	20011011BE348	2019-2020	FE AI&DS SEM I
227	2020.21	Ritesh Singh Janardan Kushwaha	20011011BE350	2019-2020	FE AI&DS SEM I
228	2020.21	Arman Himmatsaheb Inamdar	20011011BE351	27/01/2021	FE AI&DS SEM I
229	2020.21	Onkar Ashok Patil	20011011BE365	27/01/2021	FE AI&DS SEM I
230	2020.21	Tushar Amol Patil	20011011BE403	28/01/2021	FE AI&DS SEM I



231	2020.21	Shreyas Suresh Jadhav	20011011BE404		FE AI&DS SEM I
232	2020.21	Sai Subhash Para	20011011BE413	2019-2020	FE AI&DS SEM I
233	2020.21	Rohit Dnyaneshwar Chavan	20011011BE426	28/01/2021	FE AI&DS SEM I
234	2020.21	Ajinkya Annarao Jadhav	20011011BE427	28/01/2021	FE AI&DS SEM I
235	2020.21	Vishal Krishnaji More	20011011BE428	28/01/2021	FE AI&DS SEM I
236	2020.21	Suhani Ramesh Gaikwad	20011011BE445	2019-2020	FE AI&DS SEM I
237	2020.21	Harshad Shankar Chavan	20011011BE497	29/01/2021	FE AI&DS SEM I
238	2020.21	Bhushan Pradip Ambule	20011011BE523		FE AI&DS SEM I
239	2020.21	Vishwajeet Ishwar Patil	20011011BE539	2019-2020	FE AI&DS SEM I
240	2020.21	Imran Kalamuddin Shaikh	20011011BE575	2019-2020	FE AI&DS SEM I
241	2020.21	Manali Sanjay Gaikwad	20011011BE622	02-04-2021	FE AI&DS SEM I
242	2020.21	Aditya Verma	20011011BE625	02-04-2021	FE AI&DS SEM I
243	2020.21	Piyusha Deepak Shinde	20011011BE626	02-04-2021	FE AI&DS SEM I
244	2020.21	Bhargav Nitin Arondekar	20011011BE638		FE AI&DS SEM I
245	2020.21	Jyoti Prakash Rout	20011011BE643	2019-2020	FE AI&DS SEM I
246	2020.21	Chaitanya Rajesh Deokar	20011011BE220	14/01/2021	FE AI&DS SEM I
247	2020.21	Nilambari Vijay Patil	20011011BE471	29/01/2021	FE AI&DS SEM I
248	2020.21	Pradhumna Ravindra Kitukale	20021011BE270	15/01/2021	FE AI&DS SEM I
249	2020.21	Rutuja Raju Burde	20021011BE274	2019-2020	FE AI&DS SEM I
250	2020.21	Mayur Chintaman Gadekar	20021011BE295	16/01/2021	FE AI&DS SEM I
251	2020.21	Yash Bhausaheb Waghechaure	20021011BE309	16/01/2021	FE AI&DS SEM I
252	2020.21	Abhijeet Gorakshnath Kurhe	20021011BE332	2019-2020	FE AI&DS SEM I
253	2020.21	Ameya Sandip Shinde	20021011BE363	27/01/2021	FE AI&DS SEM I
254	2020.21	Tejal Liladhar Bhole	20021011BE376	2019-2020	FE AI&DS SEM I
255	2020.21	Sahil Suresh Bhatode	20021011BE382	27/01/2021	FE AI&DS SEM I
256	2020.21	Sakshi Vinod Tayade	20021011BE384	2019-2020	FE AI&DS SEM I
257	2020.21	Pranay Vinod Patil	20021011BE389	28/01/2021	FE AI&DS SEM I
258	2020.21	Yash Ganesh Sakharkar	20021011BE391	28/01/2021	FE AI&DS SEM I
259	2020.21	Prathmesh Ganesh Zade	20021011BE416	28/01/2021	FE AI&DS SEM I
260	2020.21	Prathamesh Yashwant Rohokale	20021011BE476	2019-2020	FE AI&DS SEM I
261	2020.21	Yash Pravin Chandurkar	20021011BE485	29/01/2021	FE AI&DS SEM I
262	2020.21	Akash Raj	20021011BE617	02-03-2021	FE AI&DS SEM I
263	2020.21	Ashish Madhukar Kolhe	20021021BE176	14/01/2021	FE AI&DS SEM I
264	2020.21	Vivek Arun Patil	20021021BE177	15/01/2021	FE AI&DS SEM I
265	2020.21	Suraj Sunil Raut	20021021BE182	2019-2020	FE AI&DS SEM I
266	2020.21	Abhishek Chandrakant Gambhire	20031011BE256	15/01/2021	FE AI&DS SEM I
267	2020.21	Jyoti Purushottam Dupare	20031011BE317	2019-2020	FE AI&DS SEM I
268	2020.21	Shivecharan Suresh Waghmare	20031011BE387	2019-2020	FE AI&DS SEM I
269	2020.21	Prasad Rajendra Chavan	20031011BE406	28/01/2021	FE AI&DS SEM I
270	2020.21	Jay Mohan Adhav	20031011BE471		FE AI&DS SEM I
271	2020.21	Sanskruti Raju Behar	20031011BE515	29/01/2021	FE AI&DS SEM I
272	2020.21	Yogesh Arunlal Limbore	20051011BE421	28/01/2021	FE AI&DS SEM I
273	2020.21	Mayur Sandip Gosavi	20051011BE565	2019-2020	FE AI&DS SEM I
274	2020.21	Shubham Jagannath Ghongade	20061011BE248	15/01/2021	FE AI&DS SEM I
275	2020.21	Gaurav Prabhakar Lavankar	20061011BE594	30/01/2021	FE AI&DS SEM I
276	2020.21	Viraj Nitin Garje	20071011BE450	2019-2020	FE AI&DS SEM I
277	2020.21	Nikhil Vishwajit Sonone	20081011BE345	27/01/2021	FE AI&DS SEM I





278	2020.21	Mrunal Mallikarjun Shrigan	20081011BE437	2019-2020	FE AI&DS SEM I
279	2020.21	Pankaj Raju Rathod	20091011BE538	29/01/2021	FE AI&DS SEM I
280	2020.21	Shrutika Sanjay Sankpal	21021011BE221	14/01/2021	FE AI&DS SEM I
281	2020.21	Suraj Ganesh Chavan	EN18186351	05-07-2018	SE Compl Sem I
282	2020.21	Kshitij Jitendra Kamble	EN18220306	21/07/2018	SE Compl Sem I
283	2020.21	Aquib Khan Arshad Khan	EN18265759	28/08/2018	SE Compl Sem I
284	2020.21	Vishwajeet Pandit Gaikwad	SOE1603315	02-08-2016	SE Compl Sem I
285	2020.21	Anuja Govindrao Belge	EN18147388	16/07/2018	SE Compl Sem I
286	2020.21	Kunal Deepak Adagale	19031081F3	2019-2020	SE Compl Sem I
287	2020.21	Anjali Ramesh Parmar	19011011BE134	2019-2020	SE Compl Sem I
288	2020.21	Aryan	19111011BE138	2019-2020	SE Compl Sem I
289	2020.21	Omkar Sharad Nandode	19021021BE37	2019-2020	SE Compl Sem I
290	2020.21	Atharv Rajendra Patil	19021011BE90	2019-2020	SE Compl Sem I
291	2020.21	Ayush Baliyan	19011011BE176	14/08/2019	SE Compl Sem I
292	2020.21	Shahbaz Sagir Ahmad	19011011BE44		SE Compl Sem I
293	2020.21	Shivam Sanjay Bharati	EN18113059	19/07/2018	SE Compl Sem I
294	2020.21	Pratik Ramachandra Bhosale	EN18178357	20/07/2018	SE Compl Sem I
295	2020.21	Prathamesh Sanjay Surve	20011011BE272	2019-2020	SE Compl Sem I
296	2020.21	Sourav Yadav	20011011BE277	15/01/2021	SE Compl Sem I
297	2020.21	Arbaz Allaudin Sayyed	20011011BE283	15/01/2021	SE Compl Sem I
298	2020.21	Shubham Chandrakant Ghadge	20011011BE304	16/01/2021	SE Compl Sem I
299	2020.21	Shrinath Sampat Kadam	20011011BE305	16/01/2021	SE Compl Sem I
300	2020.21	Sejal Suresh Rao Dhondge	20011011BE311	2019-2020	SE Compl Sem I
301	2020.21	Snehal Bhauso Jadhav	20011011BE438	28/01/2021	SE Compl Sem I
302	2020.21	Vaishnavi Uday Nehe	20011011BE441	2019-2020	SE Compl Sem I
303	2020.21	Onkar Pramod Utekar	20011011BE467	29/01/2021	SE Compl Sem I
304	2020.21	Pushpanjali Shivaji Dabade	20011011BE478	29/01/2021	SE Compl Sem I
305	2020.21	Vyankatesh Dnyaneshwar Shinde	20011011BE505	29/01/2021	SE Compl Sem I
306	2020.21	Mayur Mukund Kondhare	20011011BE519	2019-2020	SE Compl Sem I
307	2020.21	Rohan Bhaurao Awate	20011011BE532	29/01/2021	SE Compl Sem I
308	2020.21	Prathamesh Narayan Desai	20011011BE534	2019-2020	SE Compl Sem I
309	2020.21	Vishal Kumar Mishra	20011011BE662	15/02/2021	SE Compl Sem I
310	2020.21	Harjot Kaur Gurmeet Singh Hanspal	20011021BE175	2019-2020	SE Compl Sem I
311	2020.21	Koustubh Kishor Juvekar	200111011BE260	2019-2020	SE Compl Sem I
312	2020.21	Ashar Abdullah Mohammad Asrar	200111011BE521	2019-2020	SE Compl Sem I
313	2020.21	Dipali Machindra Talekar	200111011BE568	30/01/2021	SE Compl Sem I
314	2020.21	Prashant Vikram Kedari	20021011BE308	16/01/2021	SE Compl Sem I
315	2020.21	Krutika Mahesh Girme	20021011BE439		SE Compl Sem I
316	2020.21	Nikhilraj Sanjay Desale	20021011BE464	2019-2020	SE Compl Sem I
317	2020.21	Sandhya Bhagwan Ranmale	20021011BE473	2019-2020	SE Compl Sem I
318	2020.21	Ketan Sakharan Mhaske	20021011BE501	29/01/2021	SE Compl Sem I
319	2020.21	Siddharth Arjun Gaikwad	20031011BE300	16/01/2021	SE Compl Sem I
320	2020.21	Ketan Kailas Ohal	20061011BE454	2019-2020	SE Compl Sem I
321	2020.21	Rohan Haridas Pawar	19011021BE48	2019-2020	SE Compl Sem I
322	2020.21	Alisha Firoz Shaikh	21011011BE277	2019-2020	SE Compl Sem I
323	2020.21	Christopher William Fernandes	EN18208526	28/08/2018	SE Compl Sem I
324	2020.21	Pranav Ashok Gadge	EN18113187	18/07/2018	SE Compl Sem I



325	2020.21	Bhuyan Harishankar	EN18193209	29/08/2018	SE Compl Sem I
326	2020.21	Adarsh Rai	19111011BE137	2019-2020	SE Compl Sem I
327	2020.21	Prajwal Milindkumar Kamdi	EN18205771	21/07/2018	SE Compl Sem I
328	2020.21	Shubham Suryakant Kanchangire	EN18175440	28/08/2018	SE Compl Sem I
329	2020.21	Pallavi Anil Mane	EN18141616	07-09-2018	SE Compl Sem I
330	2020.21	Sharon Mathew	EN18211862	29/08/2018	SE Compl Sem I
331	2020.21	Sahadev Sukhadev Ade	19091011BE67	2019-2020	SE Compl Sem I
332	2020.21	Yash Girish Joshi	EN18177222	19/07/2018	SE Compl Sem I
333	2020.21	Aditya Shivaji Bhor	19011011BE144	2019-2020	SE Compl Sem I
334	2020.21	Aditya Bishvajit Sinha	19111011BE157	2019-2020	SE Compl Sem I
335	2020.21	Yash Dinkar Bahirat	190101011BE92	2019-2020	SE Compl Sem I
336	2020.21	Akash Prakash Kanar	19021011BE166	2018-2019	SE Compl Sem I
337	2020.21	Ajay Haridas Shinde	EN18120297	28/08/2018	SE Compl Sem I
338	2020.21	Adarsh Kumar Jha	19111011BE136	2019-2020	SE Compl Sem I
339	2020.21	Baljeet Singh Katoch	19111011BE147	2019-2020	SE Compl Sem I
340	2020.21	Vaishnavi Bhaskar Hemade	EN18158337	20/07/2018	SE Compl Sem I
341	2020.21	Kiran Vijay Ingale	EN18208909	29/08/2018	SE Compl Sem I
342	2020.21	Prathamesh Suresh Jadhav	19011081F5	2019-2020	SE Compl Sem I
343	2020.21	Mohiuddin Masood Karimkhan	EN18146459	04-07-2018	SE Compl Sem I
344	2020.21	Ajay Vinod Mali	19021011BE102	08-05-2019	SE Compl Sem I
345	2020.21	Akshada Bansilal Mane	EN18167547	2019-2020	SE Compl Sem I
346	2020.21	Aniket Sandeep Wankhede	19021011BES2	26/07/2019	SE Compl Sem I
347	2020.21	Abhishek Shankar Pagare	19011011BE170	2019-2020	SE Compl Sem I
348	2020.21	Ajay Rajendra Thengale	19061011BE121	2019-2020	SE Compl Sem I
349	2020.21	Akash Jitendra Khamkar	190101011BE104	08-05-2019	SE Compl Sem I
350	2020.21	Akshata Santosh Vaidya	19011011BE145	2019-2020	SE Compl Sem I
351	2020.21	Shweta Rajendra Bhosale	19011011BE164	2019-2020	SE Compl Sem I
352	2020.21	Akshay Motiram Shinde	190101011BE86	2019-2020	SE Compl Sem I
353	2020.21	Aman Firoz Attar	19011011BE140	2018-2019	SE Compl Sem I
354	2020.21	Aman Kumar Alakh Singh	19011011BE173	14/08/2019	SE Compl Sem I
355	2020.21	Ameay Pappu Washilkar	19011011BE58	26/07/2019	SE Compl Sem I
356	2020.21	Amisha Sanjay Wankhede	19011011BE48	2019-2020	SE Compl Sem I
357	2020.21	Anand Gorakh Gawali	19011011BE125	2019-2020	SE Compl Sem I
358	2020.21	Aniket Balkrushna Kshirsagar	19061011BE110	08-05-2019	SE Compl Sem I
359	2020.21	Abhishek Vitthal Farande	19021011BE118	2019-2020	SE Compl Sem I
360	2020.21	Anujay Sunil Nikalje	19031011BE49	2019-2021	SE Compl Sem I
361	2020.21	Shubham Subhash Gaikwad	190101011BE105	2019-2020	SE Compl Sem I
362	2020.21	Chetan Dinesh Nagane	19011011BE69	27/07/2019	SE Compl Sem I
363	2020.21	Rutuja Bhausaheb Jagtap	190101011BE77	2019-2020	SE Compl Sem I
364	2020.21	Digvijay Maheshkumar Rajebhosale	190101011BE61	2019-2020	SE Compl Sem I
365	2020.21	Kashish Rajiv Kumar	19011011BE190	31/08/2019	SE Compl Sem I
366	2020.21	Fiza Yunus Shaikh	19011011BE158	2019-2020	SE Compl Sem I
367	2020.21	Ganesh Dinkar Futane	19021011BE80	2019-2020	SE Compl Sem I
368	2020.21	Gopi Gourdas Mahant	19011011BE85	2019-2020	SE Compl Sem I
369	2020.21	Gourav Sunil Mahajan	19111031BE38	2019-2020	SE Compl Sem I
370	2020.21	Abhishek Pradip Yadav	19011011BE47	2019-2020	SE Compl Sem I
371	2020.21	Rutuja Raghunath Wagh	19071011BE107	2019-2020	SE Compl Sem I



372	2020.21	Suyog Jitendra Chaudhari	EN18246372	21/07/2018	SE Comp1 Sem I
373	2020.21	Monalisa Biswaranjan Nayak	19011011BE56	26/07/2019	SE Comp1 Sem I
374	2020.21	Nayan Dinkar Jagtap	19011011BE154	2019-2020	SE Comp1 Sem I
375	2020.21	Nainesh Hitesh Bhai Parikh	EN18263986	29/08/2018	SE Comp1 Sem I
376	2020.21	Hardik Dinkar Wasekar	19031011BE112	2019-2020	SE Comp1 Sem I
377	2020.21	Harshal Ashok Wagh	19021011BE93	2019-2020	SE Comp1 Sem I
378	2020.21	Harshal Bharat Walke	19011011BE114	08-05-2019	SE Comp1 Sem I
379	2020.21	Harsh Rajsingh	19011011BE131	2019-2020	SE Comp1 Sem I
380	2020.21	Himanshu Vishnukumar Agarwal	19111031BE33	2019-2020	SE Comp1 Sem I
381	2020.21	Ishika Ranjit Sinha	19111011BE156	2019-2020	SE Comp1 Sem I
382	2020.21	Janhavi Vijaykumar Mudaliar	19011011BE132	2019-2020	SE Comp1 Sem I
383	2020.21	Jyoti Durgaram Choudhari	19011011BE149	2019-2020	SE Comp1 Sem I
384	2020.21	Karan Rajender Kaul	19011011BE78	2019-2020	SE Comp1 Sem I
385	2020.21	Kartik Ratnakara Poojari	19011011BE53	2019-2020	SE Comp1 Sem I
386	2020.21	Khushi Yashwantrao Chauhan	19011011BE95	2019-2020	SE Comp1 Sem I
387	2020.21	Kiara Amir Jamal	19011011BE97	2019-2020	SE Comp1 Sem I
388	2020.21	Kiran Beejaram Devasi	19011011BE148	2019-2020	SE Comp1 Sem I
389	2020.21	Kiran Kisan Chavan	19091011BE59	26/07/2019	SE Comp1 Sem I
390	2020.21	Pramod Dipak Pathade	19021011BE70	2019-2020	SE Comp1 Sem I
391	2020.21	Komal Anil Powar	19011011BE100	2019-2020	SE Comp1 Sem I
392	2020.21	Krushnakant Ramesh Bombe	190101011BE79	2019-2020	SE Comp1 Sem I
393	2020.21	Manish Kumar Sahay	19011011BE172	2019-2020	SE Comp1 Sem I
394	2020.21	Mansi Sanjay Gaikwad	19011011BE152	2019-2020	SE Comp1 Sem I
395	2020.21	Maroof Masoodali Sayyed	19011011BE127	2019-2020	SE Comp1 Sem I
396	2020.21	Mayank Prashant Dhamal	190101011BE99	2019-2020	SE Comp1 Sem I
397	2020.21	Minku Kumari Alakh Singh	19011011BE174	2019-2020	SE Comp1 Sem I
398	2020.21	Muskan Kashinath Sawant	19011031BE51	2019-2020	SE Comp1 Sem I
399	2020.21	Namdev Tukaram Shinde	19011011BE50	2019-2020	SE Comp1 Sem I
400	2020.21	Nancy Manoj Kumar Singh	19111011BE135	2019-2020	SE Comp1 Sem I
401	2020.21	Kunal Vikas Singh	EN18250640	23/07/2018	SE Comp1 Sem I
402	2020.21	Nikhil Rajesh Chhatraband	19051011BE117	2019-2020	SE Comp1 Sem I
403	2020.21	Nikhil Srivastava	19011031BE50	2019-2020	SE Comp1 Sem I
404	2020.21	Ninad Prashant Waghmare	19011011BE54	2019-2020	SE Comp1 Sem I
405	2020.21	Vaishnavi Jaywant Khatate	19061011BE165	13/08/2019	SE Comp1 Sem I
406	2020.21	Pooja Anant Kamble	19031011BE57	2019-2020	SE Comp1 Sem I
407	2020.21	Pooja Avinash Bahirat	19061011BE46	2019-2020	SE Comp1 Sem I
408	2020.21	Prabodhan Pralhad Sonawane	19031011BE91	2019-2020	SE Comp1 Sem I
409	2020.21	Prajakta Bharat Kadam	190101011BE71	2019-2020	SE Comp1 Sem I
410	2020.21	Prajwal Dattatray Padwal	19011011BE146	08-08-2019	SE Comp1 Sem I
411	2020.21	Prakshya Prabina Das	19111011BE140	08-08-2019	SE Comp1 Sem I
412	2020.21	Pranali Popat Chaudhari	19021011BE87	2019-2020	SE Comp1 Sem I
413	2020.21	Pranoti Hanumant Chavan	190101011BE84	2019-2020	SE Comp1 Sem I
414	2020.21	Pratik Anshabapu Narsale	19021011BE108	2019-2020	SE Comp1 Sem I
415	2020.21	Pratik Raju Hiwrale	19031011BE60	2019-2020	SE Comp1 Sem I
416	2020.21	Pratiksha Santosh Kanade	19021011BE122	2019-2020	SE Comp1 Sem I
417	2020.21	Pravin Santosh Teli	19021011BE124	2019-2020	SE Comp1 Sem I
418	2020.21	Rahul Dashrath Choughule	EN18247814	10-07-2018	SE Comp1 Sem I



419	2020.21	Rahul Kumar Singh	19111011BE73	2019-2020	SE Compl Sem I
420	2020.21	Rajat Harish Chandra Tiwari	19011011BE139	2019-2020	SE Compl Sem I
421	2020.21	Ram Vijay Patil	19021011BE96	2019-2020	SE Compl Sem I
422	2020.21	Rithik Kumar Dehuria	19011031BE44	2019-2020	SE Compl Sem I
423	2020.21	Riya Nilam Chordiya	19011011BE153	2019-2020	SE Compl Sem I
424	2020.21	Rohan Singh Rathore	19111011BE132		SE Compl Sem I
425	2020.21	Rohit Kumar	19111041BE23	2019-2020	SE Compl Sem I
426	2020.21	Rupesh Dattatray Borkar	19011011BE115	08-06-2019	SE Compl Sem I
427	2020.21	Aditya Lalit Patil	19011011BE185	2019-2020	SE Compl Sem I
428	2020.21	Aditya Avinash Kadam	EN18193757	28/08/2018	SE Compl Sem I
429	2020.21	Sachin Prabhakar Rahane	19011011BE64	2019-2020	SE Compl Sem I
430	2020.21	Sakshi Sandeep Kale	19021011BE160	2019-2020	SE Compl Sem I
431	2020.21	Sakshi Subhash Yeole	190101011BE89	2019-2020	SE Compl Sem I
432	2020.21	Samrudhi Prashant Jaiswal	19021011BE106	2019-2020	SE Compl Sem I
433	2020.21	Samyak Sanjay Gade	19031011BE101	2019-2020	SE Compl Sem I
434	2020.21	Sanchit Baliram Shinde	19011011BE151	2019-2020	SE Compl Sem I
435	2020.21	Sanket Sunil Kadam	19011011BE98	2018-2019	SE Compl Sem I
436	2020.21	Saurabh Dnyandeo Netake	19021011BE62	2019-2020	SE Compl Sem I
437	2020.21	Sharadkumar Mahesh Zarpkar	19011011BE65	2019-2020	SE Compl Sem I
438	2020.21	Sharvari Harishchandra Somwanshi	19011011BE161	2019-2020	SE Compl Sem I
439	2020.21	Shishir Agrahari	19111031BE52	08-08-2019	SE Compl Sem I
440	2020.21	Shivam Ashok Deshmukh	19011011BE109	2019-2020	SE Compl Sem I
441	2020.21	Shivam Venkatrao Ware	19021011BE55	2019-2020	SE Compl Sem I
442	2020.21	Shivani Ravindra Patil	19011011BE150	2019-2020	SE Compl Sem I
443	2020.21	Shivani Shivaji Patil	19011011BE129	2019-2020	SE Compl Sem I
444	2020.21	Shivratna Shivling Dubukwad	19051011BE72	27/07/2019	SE Compl Sem I
445	2020.21	Shraddha Shrikant Sawant	19031011BE76	27/07/2019	SE Compl Sem I
446	2020.21	Shreya Suresh Shinde	19031011BE74	2019-2020	SE Compl Sem I
447	2020.21	Shudhanshu Kumar Mishra	19111011BE130	2019-2020	SE Compl Sem I
448	2020.21	Siddesh Kanhyya Minekar	19091011BE103	2019-2020	SE Compl Sem I
449	2020.21	Siddharth Maheshwar Wagh	19011011BE123	2019-2020	SE Compl Sem I
450	2020.21	Siddhesh Sandeep Chinchmalatpure	19021011BE111	2019-2020	SE Compl Sem I
451	2020.21	Papathoti Solomon Leo	19111011BE142	2019-2020	SE Compl Sem I
452	2020.21	Suraj Gajanan Patil	19011011BE162	08-10-2019	SE Compl Sem I
453	2020.21	Sushma Laxminarayana Battula	19011031BE26	2019-2020	SE Compl Sem I
454	2020.21	Taabish Farid Khan	19011011BE88	2019-2020	SE Compl Sem I
455	2020.21	Tanishk Chandrashekhkar Nakhawa	19081011BE119	2019-2020	SE Compl Sem I
456	2020.21	Tejas Suhas Sarode	19021081F4	2019-2020	SE Compl Sem I
457	2020.21	Vaishnav Balasaheb Kshirsagar	19011011BE128	2019-2020	SE Compl Sem I
458	2020.21	Vanshaj Srivastava	19011031BE23	08-04-2019	SE Compl Sem I
459	2020.21	Vanshika Shashi Kapoor	19011011BE159	2019-2020	SE Compl Sem I
460	2020.21	Vipul Gorakh Kandge	190101011BE94	2019-2020	SE Compl Sem I
461	2020.21	Yash Suresh Trimbake	19031011BE63	2019-2020	SE Compl Sem I
462	2020.21	Piyush Ganesh Sonawane	EN16120365		SE Compl Sem I
463	2020.21	Artee Chandan Rathod	EN18143285	17/07/2018	SE Compl Sem I
464	2020.21	Ritika Joshi	EN18166643	18/07/2018	SE Compl Sem I
465	2020.21	Om Sunil Vibhandik	EN18165683	05-07-2018	SE Compl Sem I



466	2020.21	Ankit Kumar Mishra	19111021BE46	2019-2020	SE Mech I Sem I
467	2020.21	Kshitij Sushant Bhagat	19011021BE30	2019-2020	SE Mech I Sem I
468	2020.21	Pavan Vijay Chavan	19091021BE40	2019-2020	SE Mech I Sem I
469	2020.21	Digvijay Dhananjay Shingade	19031021BE32	2019-2020	SE Mech I Sem I
470	2020.21	Prajwal Hanumant Gaikwad	19011081F2	2019-2020	SE Mech I Sem I
471	2020.21	Ajay Rameshwar Ghonge	19021021BE28	26/07/2019	SE Mech I Sem I
472	2020.21	Akshay Satyanarayan Giri	19051021BE24	2019-2020	SE Mech I Sem I
473	2020.21	Sanket Gopal Hira	19011021BE25		SE Mech I Sem I
474	2020.21	Shubham Gopichand Kapate	19021021BE42	2019-2020	SE Mech I Sem I
475	2020.21	Jatin Jagannath Khanvilkar	19021021BE54	2019-2020	SE Mech I Sem I
476	2020.21	Mayur Ravsaheb Khedkar	19071021BE20	2019-2020	SE Mech I Sem I
477	2020.21	Prathamesh Vijay Kumbhar	19021021BE45	2019-2020	SE Mech I Sem I
478	2020.21	Kshitij Virendra Mahajani	19011021BE17	2019-2020	SE Mech I Sem I
479	2020.21	Pratik Subhash Nalkar	19011021BE49	2019-2020	SE Mech I Sem I
480	2020.21	Narendra Dnyaneshwer Patil	1901021BE22	2019-2020	SE Mech I Sem I
481	2020.21	Jitesh Manoj Pawar	19091081F1	2019-2020	SE Mech I Sem I
482	2020.21	Ishwar Narhari Phad	19071021BE52	2019-2020	SE Mech I Sem I
483	2020.21	Pralhad Balaji Phad	19071021BE53	2019-2020	SE Mech I Sem I
484	2020.21	Adityan Ashok Kumar	SOE1704353	06-08-2017	SE Mech I Sem I
485	2020.21	Amalraj Pillai	EN18265743	29/08/2018	SE Mech I Sem I
486	2020.21	Ankush Mahendra Badgujar	SOE1704087	25/07/2017	SE Mech I Sem I
487	2020.21	Kunal Kisanrao Barge	EN18236320	20/07/2018	SE Mech I Sem I
488	2020.21	Saurabh Krishna Bendarkar	EN18216450	17/07/2018	SE Mech I Sem I
489	2020.21	Yash Manohar Bhise	EN18174756	14/07/2018	SE Mech I Sem I
490	2020.21	Harshwardhan Ramesh Bhondave	EN18249865	19/07/2018	SE Mech I Sem I
491	2020.21	Manish Bibhishan Raut	EN18250870	2019-2020	SE Mech I Sem I
492	2020.21	Pratik Arun Birajdar	EN18101816	10-07-2018	SE Mech I Sem I
493	2020.21	Rohan Suresh Chandhere	EN18184458	20/07/2018	SE Mech I Sem I
494	2020.21	Shubham Prakash Chaudhari	SOE1704142	26/07/2017	SE Mech I Sem I
495	2020.21	Vivek Nandlal Chaudhary	EN18171110	20/07/2018	SE Mech I Sem I
496	2020.21	Satish Tanaji Chavhan	SOE1704147	26/07/2017	SE Mech I Sem I
497	2020.21	Rohit Ramprakash Dahiya	EN18218294	11-07-2018	SE Mech I Sem I
498	2020.21	Rushiraj Devendra Daware	EN18112530	21/07/2018	SE Mech I Sem I
499	2020.21	Rajat Dilip Deshmukh	SOE1704188	27/07/2017	SE Mech I Sem I
500	2020.21	Shrikrushna Balasaheb Deshmukh	EN18182910	12-07-2018	SE Mech I Sem I
501	2020.21	Digambar Atmaram Suryawanshi	EN18253778	16/07/2018	SE Mech I Sem I
502	2020.21	Sudarshan Krishna Gawali	SOE1704620	28/08/2017	SE Mech I Sem I
503	2020.21	Shubham Suryakant Pawar	EN18266784	29/08/2018	SE Mech I Sem I
504	2020.21	Chhabildas Prakash Zope	EN18149824	21/07/2018	SE Mech I Sem I
505	2020.21	Ravi Lalubhai Nayak	20011011BE226	14/01/2021	SE Mech I Sem I
506	2020.21	Abhishek Dnyaneshwar Raut	20011011BE251	15/01/2021	SE Mech I Sem I
507	2020.21	Akash Chandrakant Walake	20011011BE267	15/01/2021	SE Mech I Sem I
508	2020.21	Apeksha Subhash Devkar	20011011BE269	15/01/2021	SE Mech I Sem I
509	2020.21	Sumit Arvind Bhosale	20011011BE281	15/01/2021	SE Mech I Sem I
510	2020.21	Shubham Dharmesh Parmar	20011011BE288	16/01/2021	SE Mech I Sem I
511	2020.21	Rutuja Arun Chavan	20011011BE292	16/01/2021	SE Mech I Sem I
512	2020.21	Animesh Manoj Pandey	20011011BE298	16/01/2021	SE Mech I Sem I



513	2020.21	Yash Sunil Kadu	20011011BE299	16/01/2021	SE Mech I Sem I
514	2020.21	Shubham Tulshiram Ghule	20011011BE310	16/01/2021	SE Mech I Sem I
515	2020.21	Abhishikt Anil Parit	20011011BE312	16/01/2021	SE Mech I Sem I
516	2020.21	Siddesh Namdeo Pinjan	20011011BE314	16/01/2021	SE Mech I Sem I
517	2020.21	Ganesh Keshav Kadam	20011011BE324	16/01/2021	SE Mech I Sem I
518	2020.21	Ritesh Rakesh Yadav	20011011BE416	28/01/2021	SE Mech I Sem I
519	2020.21	Akshay Santosh Walunj	20011011BE417	28/01/2021	SE Mech I Sem I
520	2020.21	Shubham Mahadev Bamane	20011011BE431	28/01/2021	SE Mech I Sem I
521	2020.21	Kunal Dnyaneshwar Ranpise	20011011BE442		SE Mech I Sem I
522	2020.21	Sanket Bhanudas Janjal	20011011BE454	29/01/2021	SE Mech I Sem I
523	2020.21	Nikhil Abhimanyu Ronge	20011011BE456	29/01/2021	SE Mech I Sem I
524	2020.21	Nishikant Suresh Atkari	20011011BE473	2019-2020	SE Mech I Sem I
525	2020.21	Pavanraj Sambhaji Pawar	20011011BE493	29/01/2021	SE Mech I Sem I
526	2020.21	Abhishek Balasaheb Pacharne	20011011BE499	2019-2020	SE Mech I Sem I
527	2020.21	Atharv Sunil Valase	20011011BE506	2019-2020	SE Mech I Sem I
528	2020.21	Shrutik Sudhir Borhade	20011011BE507	29/01/2021	SE Mech I Sem I
529	2020.21	Vikrant Satish Sankpal	20011011BE508	29/01/2021	SE Mech I Sem I
530	2020.21	Sahil Samshuddin Ansari	20011011BE509	29/01/2021	SE Mech I Sem I
531	2020.21	Shreyash Rahul Malusare	20011011BE510	29/01/2021	SE Mech I Sem I
532	2020.21	Saif Alam Parvez Siddiqui	20011011BE521	29/01/2021	SE Mech I Sem I
533	2020.21	Rushikesh Ganesh Bomble	20011011BE530	29/01/2021	SE Mech I Sem I
534	2020.21	Akshay Gulab Bhapkar	20011011BE547	2019-2020	SE Mech I Sem I
535	2020.21	Shreyash Radhakrishna Ghule	20011011BE558	2019-2020	SE Mech I Sem I
536	2020.21	Ashutosh Lahu Sutar	20011011BE561	2019-2020	SE Mech I Sem I
537	2020.21	Faizan Shahid Shaikh	20011011BE562	30/01/2021	SE Mech I Sem I
538	2020.21	Swaroop Sachin Kulkarni	20011011BE563	30/01/2021	SE Mech I Sem I
539	2020.21	Tejas Bandu Suryawanshi	20011011BE570	30/01/2021	SE Mech I Sem I
540	2020.21	Deep Santosh More	20011011BE574	30/01/2021	SE Mech I Sem I
541	2020.21	Dewesh Ganesh Rathi	20011011BE582	2019-2020	SE Mech I Sem I
542	2020.21	Rushikesh Balasaheb Kupkar	20011011BE585	30/01/2021	SE Mech I Sem I
543	2020.21	Pradumn Bharat Nande	20011011BE586	2019-2020	SE Mech I Sem I
544	2020.21	Adam Moulani Sayyed	20011011BE599	02-01-2021	SE Mech I Sem I
545	2020.21	Amankhan Riyasat Pathan	20011011BE621	02-04-2021	SE Mech I Sem I
546	2020.21	Trushal Satish Jatania	20011011BE632	02-05-2021	SE Mech I Sem I
547	2020.21	Kishor Anandrao Jadhav	20011011BE648	02-08-2021	SE Mech I Sem I
548	2020.21	Shraddha Pradeep Rahate	20021011BE242	15/01/2021	SE Mech I Sem I
549	2020.21	Ajay Popat Shirke	20021011BE246	15/01/2021	SE Mech I Sem I
550	2020.21	Ashitosh Prakash Pardeshi	20021011BE256	15/01/2021	SE Mech I Sem I
551	2020.21	Abhijit Sampat Wagh	20021011BE290	16/01/2021	SE Mech I Sem I
552	2020.21	Tushar Manshiram Tapkir	20021011BE307	2019-2020	SE Mech I Sem I
553	2020.21	Tejas Dilip Jadhav	20021011BE400	28/01/2021	SE Mech I Sem I
554	2020.21	Vishal Ramrao Ganjare	20021011BE409	28/01/2021	SE Mech I Sem I
555	2020.21	Avinash Ramesh Bankar	20021011BE443	28/01/2021	SE Mech I Sem I
556	2020.21	Milind Rohidas Patil	20021011BE453	29/01/2021	SE Mech I Sem I
557	2020.21	Borude Akash Sudhakar	20021011BE465	29/01/2021	SE Mech I Sem I
558	2020.21	Prajwal Sudam Kharpude	20021011BE512	29/01/2021	SE Mech I Sem I
559	2020.21	Ganesh Dattatraya Sutar	20021011BE559		SE Mech I Sem I



560	2020.21	Shobhika Nitin Kadam	20031011BE203	2015	SE Mech I Sem I
561	2020.21	Suraj Vijay Kharat	20031011BE230	14/01/2021	SE Mech I Sem I
562	2020.21	Sachin Anil Rankhambe	20031011BE282	15/01/2021	SE Mech I Sem I
563	2020.21	Aboli Shrikant Shinde	20031011BE284	15/01/2021	SE Mech I Sem I
564	2020.21	Kunal Vikas Sadakale	20031011BE291	16/01/2021	SE Mech I Sem I
565	2020.21	Sumeet Martand Aiwale	20031011BE422	28/01/2021	SE Mech I Sem I
566	2020.21	Suhas Mahadev Gaikwad	20031011BE444	2019-2020	SE Mech I Sem I
567	2020.21	Rahul Baliram Sonawane	20031011BE527	29/01/2021	SE Mech I Sem I
568	2020.21	Omkar Sagar Dhonkar	20031011BE531	29/01/2021	SE Mech I Sem I
569	2020.21	Onkar Arun Salve	20031011BE536	29/01/2021	SE Mech I Sem I
570	2020.21	Dhadesh Amasidha Honmore	20031011BE570	30/01/2021	SE Mech I Sem I
571	2020.21	Pranay Jaykumar Kusare	20031011BE575	30/01/2021	SE Mech I Sem I
572	2020.21	Manish Shivaji Harale	20031011BE590	30/01/2021	SE Mech I Sem I
573	2020.21	Saurabh Rahul Dhawale	20031021BE179	15/01/2021	SE Mech I Sem I
574	2020.21	Shubham Vijay Lokhande	20051011BE440	28/01/2021	SE Mech I Sem I
575	2020.21	Chetan Tanaji Thombare	20061011BE511	29/01/2021	SE Mech I Sem I
576	2020.21	Manjeet Sachin Chauhan	20091021BE183	30/01/2021	SE Mech I Sem I
577	2020.21	Rohan Gokul Phuge	19011021BE36	27/07/2019	SE Mech I Sem I
578	2020.21	Pravin Paraji Pawar	19011021BE50	2019-2020	SE Mech I Sem I
579	2020.21	Gajanan Suryakant Raut	19021021BE38	2019-2020	SE Mech I Sem I
580	2020.21	Shiva Balkrushna Rekhate	19021021BE43	2019-2020	SE Mech I Sem I
581	2020.21	Ritik Chivate	19011021BE16	2019-2020	SE Mech I Sem I
582	2020.21	Vishwajeet Pandit Rokade	19031021BE18	2019-2020	SE Mech I Sem I
583	2020.21	Sachin Sambaji Kulakarni	19111021BE41	2019-2020	SE Mech I Sem I
584	2020.21	Rohan Ramesh Satpute	19021021BE73	2019-2020	SE Mech I Sem I
585	2020.21	Dinesh Diliprao Suryawanshi	2101011BE499	29/01/2021	SE Mech I Sem I
586	2020.21	Sachin Jagadish Patil	21021011BE581	2019-2020	SE Mech I Sem I
587	2020.21	Manoj Vikas Shinde	19011021BE44	2019-2020	SE Mech I Sem I
588	2020.21	Shivam Chandrashekar Shinde	19011021BE74	2019-2020	SE Mech I Sem I
589	2020.21	Tanmay Digambar Dabhade	19031021BE34	2019-2020	SE Mech I Sem I
590	2020.21	Tejas Balasaheb Pansare	19011021BE39	08-04-2019	SE Mech I Sem I
591	2020.21	Rohit Vijaykumar Telang	19021021BE23	2019-2020	SE Mech I Sem I
592	2020.21	Himanshu Anant Thakare	19021021BE35	2019-2020	SE Mech I Sem I
593	2020.21	Sanket Vilas Toge	19061021BE19	2019-2020	SE Mech I Sem I
594	2020.21	Tushant Ashok Kumar	19111021BE47	2019-2020	SE Mech I Sem I
595	2020.21	Tushar Shashidhar Devadiga	19011081F6	2019-2020	SE Mech I Sem I
596	2020.21	Prajval Laxman Walve	190101021BE31	2019-2020	SE Mech I Sem I
597	2020.21	Prasanna Dattatray Jagtap	EN18115622	12-07-2018	SE Mech I Sem I
598	2020.21	Joshua Varghese	EN18191361	14/07/2018	SE Mech I Sem I
599	2020.21	Jaihind Vinod Kamble	EN18212830	16/07/2018	SE Mech I Sem I
600	2020.21	Ayush Yuwraj Khobragade	EN18114328	20/07/2018	SE Mech I Sem I
601	2020.21	Suraj Sidu Kolse Patil	EN18141445	13/07/2018	SE Mech I Sem I
602	2020.21	Keshav Kailash Thakur Kumar	EN18157065	29/08/2018	SE Mech I Sem I
603	2020.21	Omkar Ravindra Lagad	EN18219778	20/07/2018	SE Mech I Sem I
604	2020.21	Atharva Rajesh Malode	EN18216472	16/07/2018	SE Mech I Sem I
605	2020.21	Prithviraj Santajirao Mohite	EN18139979	07-05-2018	SE Mech I Sem I
606	2020.21	Kartik Ramesh Nair	EN18102782	28/08/2018	SE Mech I Sem I



607	2020.21	Prajwal Sadashiv Patil	EN18124504		SE Mech I Sem I
608	2020.21	Rahul Anand Ashutosh Upadhyay	EN18261384	28/08/2018	SE Mech I Sem I
609	2020.21	Pratik Bhim Reddy	SOE1704194	27/07/2017	SE Mech I Sem I
610	2020.21	Tanishq Rupesh Salunke	SOE1704173	27/07/2017	SE Mech I Sem I
611	2020.21	Sanket Rajendra Wandhekar	SOE1704297	29/07/2017	SE Mech I Sem I
612	2020.21	Ahed Ahmed Shaikh	EN18259744	29/08/2018	SE Mech I Sem I
613	2020.21	Srushti Sarjerao Shendkar	EN18237422	29/08/2018	SE Mech I Sem I
614	2020.21	Shubham Sambhaji Shewale	EN18164571	14/07/2018	SE Mech I Sem I
615	2020.21	Ruturaj Anand Taware	EN18145541	19/07/2018	SE Mech I Sem I
616	2020.21	Suraj Sharad Zanjurne	EN18217944	19/07/2018	SE Mech I Sem I
617	2020.21	Akash Sainath Thombre	EN18193378	20/07/2018	SE Mech I Sem I
618	2020.21	Himanshu Avinash Parmar	20011011BE263	2019-2020	SE Mech I Sem I
619	2020.21	Raghavendra Singh	19011021BE26	2019-2020	SE Mech I Sem I
620	2020.21	Ashwini Papat Korade	21041011BE432		SE Civil I Sem I
621	2020.21	Abhimanyu Babasaheb Tarde	EN18101826	29/08/2018	SE Civil I Sem I
622	2020.21	Rakesh Rajendra Chavan	EN18202651	15/07/2018	SE Civil I Sem I
623	2020.21	Omkar Atmaram Pawar	16011011BE204	21/10/2020	SE Civil I Sem I
624	2020.21	Shubham Yashwant Pancharas	16031011BE663	03-02-2021	SE Civil I Sem I
625	2020.21	Tejas Sanjaykumar Dongare	EN18232970	12-07-2018	SE Civil I Sem I
626	2020.21	Mayur Vijay Kondhalkar	20011011BE252	15/01/2021	SE Civil I Sem I
627	2020.21	Akshay Padmakar Kakade	20011011BE302	16/01/2021	SE Civil I Sem I
628	2020.21	Salma Javed Sayyed	20011011BE329	16/01/2021	SE Civil I Sem I
629	2020.21	Chinmay Anand Solat	20011011BE401	28/01/2021	SE Civil I Sem I
630	2020.21	Vivek Vilasrao Deshmukh	20011011BE466		SE Civil I Sem I
631	2020.21	Pawan Sanjay Mokle	20011011BE488	29/01/2021	SE Civil I Sem I
632	2020.21	Samrat Lalasaheb Patil	20011011BE496	29/01/2021	SE Civil I Sem I
633	2020.21	Shubham Sharad Pawar	20011011BE536	29/01/2021	SE Civil I Sem I
634	2020.21	Abhishek Anil Parab	20011011BE554	30/01/2021	SE Civil I Sem I
635	2020.21	Shivani Mohan Gharde	20011011BE559	30/01/2021	SE Civil I Sem I
636	2020.21	Meghraj Yuvraj Kakade	20011011BE607	02-02-2021	SE Civil I Sem I
637	2020.21	Saurabh Vijay Patare	20021011BE209	23/12/2020	SE Civil I Sem I
638	2020.21	Aditya Prashant Tarale	20021011BE241	15/01/2021	SE Civil I Sem I
639	2020.21	Shreyash Dilip Makode	20021011BE244	15/01/2021	SE Civil I Sem I
640	2020.21	Nilesh Rangnath Sawant	20021011BE293	16/01/2021	SE Civil I Sem I
641	2020.21	Meet Dasharath Mali	20021011BE318	16/01/2021	SE Civil I Sem I
642	2020.21	Mayank Vivek Thakur	20021011BE319	16/01/2021	SE Civil I Sem I
643	2020.21	Mayur Gaurav Gaikar	20021011BE330	16/01/2021	SE Civil I Sem I
644	2020.21	Shubham Vishnu Kad	20021011BE336	18/01/2021	SE Civil I Sem I
645	2020.21	Vishwaraj Chandrashekhar Kokate	20021011BE467	2019-2020	SE Civil I Sem I
646	2020.21	Sumit Vijay Satao	20021011BE480	29/01/2021	SE Civil I Sem I
647	2020.21	Adarsh Anantrao Tayde	20021011BE486	29/01/2021	SE Civil I Sem I
648	2020.21	Utkarsh Balu Patil	20021011BE491	29/01/2021	SE Civil I Sem I
649	2020.21	Gunvant Pramod Ozarkar	20021011BE533	29/01/2021	SE Civil I Sem I
650	2020.21	Siddheshwar Shirish Adki	20021011BE564	30/01/2021	SE Civil I Sem I
651	2020.21	Gaurav Ganesh Dhole	20021011BE591	30/01/2021	SE Civil I Sem I
652	2020.21	Manish Sanjay More	20031011BE225	14/01/2021	SE Civil I Sem I
653	2020.21	Snehal Balasaheb Udanshiv	20031011BE268	2019-2020	SE Civil I Sem I





654	2020.21	Nisha Vishnu Waghmare	20031011BE275	15/01/2021	SE Civil Sem I
655	2020.21	Suraj Subhash Mane	20031011BE324	16/01/2021	SE Civil Sem I
656	2020.21	Ajay Anil Bhosale	20031011BE478	29/01/2021	SE Civil Sem I
657	2020.21	Anurag Anil Waghmare	20031011BE502	29/01/2021	SE Civil Sem I
658	2020.21	Akash Sudarshan Lokhande	20031011BE503	29/01/2021	SE Civil Sem I
659	2020.21	Rushikesh Satyasen Shirsate	20031011BE550	2019-2020	SE Civil Sem I
660	2020.21	Yashshree Mangesh Dahiwile	20031011BE554	30/01/2021	SE Civil Sem I
661	2020.21	Aniket Sudhir Sonawane	20031011BE584	30/01/2021	SE Civil Sem I
662	2020.21	Ashish Ramesh Deshmukh	20041011BE226	14/01/2021	SE Civil Sem I
663	2020.21	Satish Gunwant Khude	20041011BE323	16/01/2021	SE Civil Sem I
664	2020.21	Meghana Devidas Khambait	20041011BE463	29/01/2021	SE Civil Sem I
665	2020.21	Yuvraj Dhansingh Rao Badhiye	20051011BE524	29/01/2021	SE Civil Sem I
666	2020.21	Anishka Sunil Tamkhane	20051011BE552	30/01/2021	SE Civil Sem I
667	2020.21	Meenakshi Bajarang Shendage	20061011BE480	29/01/2021	SE Civil Sem I
668	2020.21	Vikas Sahebrao Sakhare	20061011BE525	29/01/2021	SE Civil Sem I
669	2020.21	Aniket Sugriv Neharkar	20071011BE245	15/01/2021	SE Civil Sem I
670	2020.21	Tejashri Jagdish Avhad	20071011BE481	2019-2020	SE Civil Sem I
671	2020.21	Nita Dattu Koli	20081011BE481	2019-2020	SE Civil Sem I
672	2020.21	Sneha Santosh Mirje	20091011BE326	16/01/2021	SE Civil Sem I
673	2020.21	Ravindra Mangalsing Balawane	20091011BE480	2019-2020	SE Civil Sem I
674	2020.21	Arun Santosh Maher	20091011BE487	29/01/2021	SE Civil Sem I
675	2020.21	Pradip Baban Shingte	21011011BE338	20/01/2021	SE Civil Sem I
676	2020.21	Sahil Subhash Parde	21031011BE583	30/01/2021	SE Civil Sem I
677	2020.21	Dhiraj Vaijinath Huljute	EN18213027	20/07/2018	SE Civil Sem I
678	2020.21	Sandesh Vishnu Khedkar	EN18152199	21/07/2018	SE Civil Sem I
679	2020.21	Anuj Arun Lad	EN18198736	20/07/2018	SE Civil Sem I
680	2020.21	Vivek Mangesh Mankanikar	EN18198116	20/07/2018	SE Civil Sem I
681	2020.21	Vaishnavi Bhagwan Pisote	EN18250724	04-07-2018	SE Civil Sem I
682	2020.21	Aatish Yashwant Sonawane	EN18128773	20/07/2018	SE Civil Sem I
683	2020.21	Anuradha Devrao Sontakke	EN18202732	19/07/2018	SE Civil Sem I
684	2020.21	Saiprasad Nitin Thanekar	EN18112804	20/07/2018	SE Civil Sem I
685	2020.21	Vignesh Sriram	EN18263905	29/08/2018	SE Civil Sem I
686	2020.21	Ritik Dinesh Patil	EN18146273	19/07/2018	SE Civil Sem I
687	2020.21	Mohit Satish Bade	EN18166964	13/07/2018	SE Civil Sem I
688	2020.21	Anand Sunil Khune	190101041BE27	2019-2020	SE Civil Sem I
689	2020.21	Chaitanya Vanraj Bankar	19031041BE20	2019-2020	SE Civil Sem I
690	2020.21	Pranay Jagdish Diyewar	19021041BE15	27/07/2019	SE Civil Sem I
691	2020.21	Chetan Santosh Pagare	19021041BE9	2019-2020	SE Civil Sem I
692	2020.21	Devesh Kumar Katlam	19111041BE24	2019-2020	SE Civil Sem I
693	2020.21	Diksha Sugriv Shinde	19011041BE5	2019-2020	SE Civil Sem I
694	2020.21	Kartik Srinivas Shivanwar	19051041BE7	2019-2020	SE Civil Sem I
695	2020.21	Krishna Mahantappa Natikar	19011041BE12	26/07/2019	SE Civil Sem I
696	2020.21	Mohit Siddheshwar Bhujbal	19011041BE17	2019-2020	SE Civil Sem I
697	2020.21	Pauras Hanumant Mahadik	19011041BE26	2019-2020	SE Civil Sem I
698	2020.21	Suwarneshwar Ajitdada Hangargekar	EN18266025	29/08/2018	SE Civil Sem I
699	2020.21	Prathmesh Ashokrao Budhawant	19071041BE22	2019-2020	SE Civil Sem I
700	2020.21	Tejas Sudhakar Gadekar	EN18191266	21/07/2018	SE Civil Sem I



701	2020.21	Rohan Madan Ade	19091041BE21	2019-2020	SE Civil Sem I
702	2020.21	Rushikesh Motiram More	19021041BE11	2019-2020	SE Civil Sem I
703	2020.21	Satish Babasaheb Wabale	19011041BE6	2019-2020	SE Civil Sem I
704	2020.21	Shubham Dnyanoba Mane	EN18214929	07-09-2018	SE Civil Sem I
705	2020.21	Shubham Anil Rahade	19011041BE8	2019-2020	SE Civil Sem I
706	2020.21	Suraj Dnyandev Dhumal	190101041BE19	2019-2020	SE Civil Sem I
707	2020.21	Swatej Vasant Rathod	19091041BE14	27/07/2019	SE Civil Sem I
708	2020.21	Vaibhav Rajendra Tanksale	19021041BE10	2019-2020	SE Civil Sem I
709	2020.21	Shantanu Suresh Lambe	EN18260349	29/08/2018	SE Civil Sem I
710	2020.21	Kiran Rameshwar More	EN18211374	19/07/2018	SE Civil Sem I
711	2020.21	Nachiket Ankush Panchal	EN18172545	17/07/2018	SE Civil Sem I
712	2020.21	Rajkumar Balasaheb Naikwade	EN18161809	07-03-2018	SE Civil Sem I
713	2020.21	Jaydeep Dilip Pathare	EN18193047	20/07/2018	SE Civil Sem I
714	2020.21	Prajwal Sambhaji Patil	EN18206852	19/07/2018	SE Civil Sem I
715	2020.21	Pranit Vijay Jadhav	EN18143014	29/08/2018	SE Civil Sem I
716	2020.21	Aditya Chandrakant Rakh	SOE1704077	25/07/2017	SE Civil Sem I
717	2020.21	Sumit Sunil Khendad	SOE1704110	26/07/2017	SE Civil Sem I
718	2020.21	Karuna Bhaskar Pawar	SOE1704261	28/07/2017	SE Civil Sem I
719	2020.21	Akram Sallauddin Shaikh	SOE1704629	28/08/2017	SE Civil Sem I
720	2020.21	Rahul Motilal Jain	SOE1704632	28/08/2017	SE Civil Sem I
721	2020.21	Abhinay Kumar	19121031BE56	2019-2020	SE ENTC1 Sem I
722	2020.21	Afaan Shahabuddin Idrisi	19011031BE58	2019-2020	SE ENTC1 Sem I
723	2020.21	Neel Manoj Banodiya	19011031BE28	2019-2020	SE ENTC1 Sem I
724	2020.21	Nitin Venkatesh Battula	19011031BE13	2019-2020	SE ENTC1 Sem I
725	2020.21	Pratik Ramesh Bhoadatt	19081031BE31	2019-2020	SE ENTC1 Sem I
726	2020.21	Nidhi Vijaysingh Bisht	19011031BE9	2019-2020	SE ENTC1 Sem I
727	2020.21	Kona Naveen Cheerafa	19011031BE14	26/07/2019	SE ENTC1 Sem I
728	2020.21	Lakshmimanasa Shrinivas Chirivella	19111031BE55	2019-2020	SE ENTC1 Sem I
729	2020.21	Tejas Pandharinath Dabhade	19011031BE40	08-05-2019	SE ENTC1 Sem I
730	2020.21	Deepak Kumar Thakur	19111031BE34	2019-2020	SE ENTC1 Sem I
731	2020.21	Disha Deepak Hegde	EN18250715	02-07-2018	SE ENTC1 Sem I
732	2020.21	Sanghasen Pramod Ganvir	19131031BE37	2019-2020	SE ENTC1 Sem I
733	2020.21	Atharv Vinod Garpal	EN18191297	17/07/2018	SE ENTC1 Sem I
734	2020.21	Harsh Ravindrakumar Ghundiya	EN18262727	29/08/2018	SE ENTC1 Sem I
735	2020.21	Yash Jagdish Gopani	EN18264537	28/08/2018	SE ENTC1 Sem I
736	2020.21	Supriya Ramarao Gopathi	19111031BE15	2019-2020	SE ENTC1 Sem I
737	2020.21	Govind Ashok Kadam	EN18247376	21/07/2018	SE ENTC1 Sem I
738	2020.21	Yash Dhananjay Kashikar	20011011BE249	15/01/2021	SE ENTC1 Sem I
739	2020.21	Pratik Vikas Patil	20011011BE432	28/01/2021	SE ENTC1 Sem I
740	2020.21	Brijesh Harsukh Pokar	20011011BE568	30/01/2021	SE ENTC1 Sem I
741	2020.21	Roxston Richard Nirmal	20011011BE604	02-01-2021	SE ENTC1 Sem I
742	2020.21	Rohan Chandramohan Patre	20011011BE620	02-03-2021	SE ENTC1 Sem I
743	2020.21	Vivek Pradip Mahajan	20021011BE526	29/01/2021	SE ENTC1 Sem I
744	2020.21	Payal Sambhaji Kamble	20031011BE334	18/01/2021	SE ENTC1 Sem I
745	2020.21	Priya Uddhav Gutte	20071011BE340	20/01/2021	SE ENTC1 Sem I
746	2020.21	Prasad Rajendra Londhe	SOT1803729	2019-2020	SE ENTC1 Sem I
747	2020.21	Abhijeet Madhavrao Hannamshetty	19011031BE20	2019-2020	SE ENTC1 Sem I



748	2020.21	Ashutosh Ganesh Kadbhane	19011031BE43	2019-2020	SE ENTC1 Sem I
749	2020.21	Vaishnavi Pritam Kankate	19071031BE41	2019-2020	SE ENTC1 Sem I
750	2020.21	Pradnya Kishor Kapadne	EN18101669	18/07/2018	SE ENTC1 Sem I
751	2020.21	Akash Ravasaheb Kawade	19021031BE45	2019-2020	SE ENTC1 Sem I
752	2020.21	Ajay Audumbar Kokate	SOE1704216	27/07/2017	SE ENTC1 Sem I
753	2020.21	Abhishek Shyam Kurhade	EN18265748	28/08/2018	SE ENTC1 Sem I
754	2020.21	Sumit Satish Mehetre	19021031BE19	26/07/2019	SE ENTC1 Sem I
755	2020.21	Gunaji Sudip Mulak	190101031BE35	2019-2020	SE ENTC1 Sem I
756	2020.21	Sayali Madhukar Pandit	19021031BE8	2019-2020	SE ENTC1 Sem I
757	2020.21	Pranali Baban Mamadapure	19011031BE29	2019-2020	SE ENTC1 Sem I
758	2020.21	Pratik Jagdish Diyewar	19021031BE36	2019-2020	SE ENTC1 Sem I
759	2020.21	Raghavendra Singh Rathore	19011031BE32	2019-2020	SE ENTC1 Sem I
760	2020.21	Gauri Rahul Salunkhe	19011031BE18	2019-2020	SE ENTC1 Sem I
761	2020.21	Saurav Suman	19011031BE25	2019-2020	SE ENTC1 Sem I
762	2020.21	Shashwat Prabhakar Bhojar	19021031BE30	2019-2020	SE ENTC1 Sem I
763	2020.21	Shivani Harish Sharma	19011031BE17	26/07/2019	SE ENTC1 Sem I
764	2020.21	Shubham Kiran Sharma	19011031BE24	2019-2020	SE ENTC1 Sem I
765	2020.21	Shubham Pandurang Kalamkar	EN18252351	2018-2019	SE ENTC1 Sem I
766	2020.21	Devesh Dinesh Singh	19011031BE16	2019-2020	SE ENTC1 Sem I
767	2020.21	Vaishnavi Dnyaneshwar Sirsat	19021031BE11	2019-2020	SE ENTC1 Sem I
768	2020.21	Swaroop Bandu Badwe	19011031BE21	2019-2020	SE ENTC1 Sem I
769	2020.21	Vikesh Bharti Goswami	19011031BE46	2019-2020	SE ENTC1 Sem I
770	2020.21	Sakshi Chandrakant Wadhai	SOE1704149	26/07/2017	SE ENTC1 Sem I
771	2020.21	Sankalp Sanjay Wankhade	19021031BE22	2019-2020	SE ENTC1 Sem I
772	2020.21	Yash Deepak Solanke	19021031BE54	2019-2020	SE ENTC1 Sem I
773	2020.21	Mayank Parvat Singh Rajpurohit	19011031BE12	2019-2020	SE ENTC1 Sem I
774	2020.21	Niharika Pramod Dube	190101031BE39	2019-2020	SE ENTC1 Sem I
775	2020.21	Sejal Rohidas Lawande	19081031BE47	2019-2020	SE ENTC1 Sem I
776	2020.21	Himanshu Dhananjay Wankhede	EN18220171	19/07/2018	SE ENTC1 Sem I
777	2020.21	Priyanka Sagar	EN18128865	28/08/2018	TE Compl Sem I
778	2020.21	Shaibaz Habib Shaikh	EN18152043	04-07-2018	TE Compl Sem I
779	2020.21	Allaudin Husain Shaikh	EN18184810	2018-2019	TE Compl Sem I
780	2020.21	Azim Abdul Rahim Shaikh	EN18146955	29/08/2018	TE Compl Sem I
781	2020.21	Shaizan Khan	EN18108236	21/07/2018	TE Compl Sem I
782	2020.21	Rushikesh Sanjay Shinde	EN18221127	22/07/2018	TE Compl Sem I
783	2020.21	Shradha Umesh Dhore	EN18114484	20/07/2018	TE Compl Sem I
784	2020.21	Shivangi Singh	EN18174999	28/08/2018	TE Compl Sem I
785	2020.21	Shreya Rajendra Chaudhri	SOE1704323	29/07/2017	TE Compl Sem I
786	2020.21	Swapna Ramdas Dhobale	SOE1704177	27/07/2017	TE Compl Sem I
787	2020.21	Siddharth Babu Chinchankar	EN18194659	20/07/2018	TE Compl Sem I
788	2020.21	Anandkumar Omprakash Rai	SOE1704186	27/07/2017	TE Compl Sem I
789	2020.21	Siddharth Raghuvansi	EN18129064	22/07/2018	TE Compl Sem I
790	2020.21	Karan Sushant Singhasane	EN18135405	21/07/2018	TE Compl Sem I
791	2020.21	Sinjan Sanjay Basu	SOE1704330	05-08-2017	TE Compl Sem I
792	2020.21	Gaurav Khemchand Agrawal	SOE1704643	28/08/2017	TE Compl Sem I
793	2020.21	Snehal Gopal Dhole	SOE1704062	25/07/2017	TE Compl Sem I
794	2020.21	Advait Prashant Bhujbal	SOE1603378	03-08-2016	TE Compl Sem I



795	2020.21	Snehal Vaman Karale	EN18102166	28/08/2018	TE Compl Sem I
796	2020.21	Sumant Ramlu Sankurwar	EN18200888	20/07/2018	TE Compl Sem I
797	2020.21	Hemantkumar Prabhu Nikole	SOE1603346		TE Compl Sem I
798	2020.21	Tejas Sandeep Bafna	EN18115459	28/08/2018	TE Compl Sem I
799	2020.21	Rutuja Mahendra Thokale	EN18217533	20/07/2018	TE Compl Sem I
800	2020.21	Utkarsha Babu Dalvi	SOE1704088	2019-2020	TE Compl Sem I
801	2020.21	Dhanashree Bhalchandra Vaidya	EN18108318	19/07/2018	TE Compl Sem I
802	2020.21	Parikshit Dilip Aher	SOE1603213		TE Compl Sem I
803	2020.21	Varun Shashikant Patil	EN18213818	20/07/2018	TE Compl Sem I
804	2020.21	Sangharatn Bapurao Waghmare	EN18162793	21/07/2018	TE Compl Sem I
805	2020.21	Mrityunjay Mishra	EN18211357	29/08/2018	TE Compl Sem I
806	2020.21	Kshitiz Kumar	EN18102093	20/07/2018	TE Compl Sem I
807	2020.21	Rafe Mohammad	EN18125829	07-11-2018	TE Compl Sem I
808	2020.21	Jha Manas	EN18100982	28/08/2018	TE Compl Sem I
809	2020.21	Shweta Ramesh Naikawadi	EN18163314	2018-2019	TE Compl Sem I
810	2020.21	Abhay Bhairavnath Matkar	SOE1704236	28/07/2017	TE Compl Sem I
811	2020.21	Mansi Vaijinath Kulkarni	EN18214559	13/07/2018	TE Compl Sem I
812	2020.21	Riya Rahul Lunkad	EN18189058	20/07/2018	TE Compl Sem I
813	2020.21	Nevil Atindra Mehta	SOE1704654	29/08/2017	TE Compl Sem I
814	2020.21	Suraj Sunil Katore	EN18127934	29/08/2018	TE Compl Sem I
815	2020.21	Yash Sandeep Kumbhar	EN18169541	19/07/2018	TE Compl Sem I
816	2020.21	Pushyarak Badalraj Asnani	EN18134488	22/07/2018	TE Compl Sem I
817	2020.21	Kulwant Karnail Singh	EN18158858	03-07-2018	TE Compl Sem I
818	2020.21	Sahil Sudhir Pawar	EN18129671	2018-2019	TE Compl Sem I
819	2020.21	Ganesh Tararam Tak	EN18220513	28/08/2018	TE Compl Sem I
820	2020.21	Aniket Rajendra Wagh	SOE1502784		TE Compl Sem I
821	2020.21	Gauri Sureshraj Gotmare	EN18106522	16/07/2018	TE Compl Sem I
822	2020.21	Satyam Premnath Dube	SOE1704683	11-10-2017	TE Compl Sem I
823	2020.21	Adarsh Sunil Maskar	EN18115453	20/07/2018	TE Compl Sem I
824	2020.21	Adarsh Sunil Mandale	EN18157133	21/07/2018	TE Compl Sem I
825	2020.21	Dakshit Ganesh Mahadeshwar	SOE1805173		TE Compl Sem I
826	2020.21	Ajit Baban Chouhan	SOE1502548		TE Compl Sem I
827	2020.21	Prathamesh Praveen Rangneniwar	EN18106026	18/07/2018	TE Compl Sem I
828	2020.21	Abhinav Sunil Jagtap	SOE1704092	26/07/2017	TE Compl Sem I
829	2020.21	Sakshi Sachin Barve	EN18168911	21/07/2018	TE Compl Sem I
830	2020.21	Kaku Kondhayya Balaji	SOE1704332	05-08-2017	TE Compl Sem I
831	2020.21	Rahul Gopalam Kanithi	EN18197240	20/07/2018	TE Compl Sem I
832	2020.21	Rohit Raosaheb Sonawane	SOE1704114	26/07/2017	TE Compl Sem I
833	2020.21	Ashraf Mukhtar Shaikh	EN18102914	18/07/2018	TE Compl Sem I
834	2020.21	Manvi Moza	EN18242671	28/08/2018	TE Compl Sem I
835	2020.21	Veenish S Mourya	SOE1704124	26/07/2017	TE Compl Sem I
836	2020.21	Rutuja Pradip Pandit	EN18219558	20/07/2018	TE Compl Sem I
837	2020.21	Kartik Macchindra Yamgar	SOE1603291		TE Compl Sem I
838	2020.21	Bhagyashree Siddaram Muddadagi	SOE1704103	26/07/2017	TE Compl Sem I
839	2020.21	Nupur Bhupendra Shah	EN18109826	20/07/2018	TE Compl Sem I
840	2020.21	Sonali Vijay More	SOE1704108	26/07/2017	TE Compl Sem I
841	2020.21	Anmol Kumar Srivastava	SOE1704647	29/08/2017	TE Compl Sem I



842	2020.21	Trupti Shrikrishna Gaikwad	SEP1600619	08-09-2016	TE Compl Sem I
843	2020.21	Prachi Mahendrakumar Tekade	19021011BE182	23/08/2019	TE Compl Sem I
844	2020.21	Ashwin Surinder Bali	SOE1603305		TE Compl Sem I
845	2020.21	Harshal Chandrashekhar Gite	19021011BE179	22/08/2019	TE Compl Sem I
846	2020.21	Shraddha Pramod Karande	19031011BE187	29/08/2019	TE Compl Sem I
847	2020.21	Kajal Sanjay Jagtap	19021101ME4	30/08/2019	TE Compl Sem I
848	2020.21	Snehal Ajay Pol	190101011BE183	24/08/2019	TE Compl Sem I
849	2020.21	Nikita Uttam Lahane	190101011BE184	24/08/2019	TE Compl Sem I
850	2020.21	Rutuja Daulat Chakor	19071011BE194	31/08/2019	TE Compl Sem I
851	2020.21	Shivam Sanjay Desale	19021011BE189	31/08/2019	TE Compl Sem I
852	2020.21	Dheeraj Raju Kachi	19061011BE188	30/08/2019	TE Compl Sem I
853	2020.21	Anurag Kishor Kulkarni	190111011BE192	31/08/2019	TE Compl Sem I
854	2020.21	Akshata Sandeep Pawar	190101011BE191	31/08/2019	TE Compl Sem I
855	2020.21	Pallavi Subash Opalkar	190111011BE193	31/08/2019	TE Compl Sem I
856	2020.21	Shubham Pradeep Pakal	19051011BE195	31/08/2019	TE Compl Sem I
857	2020.21	Uddhav Vithal Kendre	SOE1704223	28/07/2017	TE Compl Sem I
858	2020.21	Siddhant Yuvraj Adaskar	EN18157726	20/07/2018	TE Compl Sem I
859	2020.21	Anirudh Sanjay Mhaske	EN18127458	28/08/2018	TE Compl Sem I
860	2020.21	Ashwini Jayawant Patil	EN18195233	22/07/2018	TE Compl Sem I
861	2020.21	Ankush Atinandkumar Bhandari	EN18148257	2018-2019	TE Compl Sem I
862	2020.21	Chandani Kumari	EN18115097	21/07/2018	TE Compl Sem I
863	2020.21	Kaustubh Manoj Chaudhari	EN18214036	21/07/2018	TE Compl Sem I
864	2020.21	Abhishek Kaluram Chattar	EN18132011	18/07/2018	TE Compl Sem I
865	2020.21	Ankita Anil Chavhan	EN18161727	16/07/2018	TE Compl Sem I
866	2020.21	Devaksh Ravindra Bhagat	EN18263250	29/08/2018	TE Compl Sem I
867	2020.21	Fiza Azam	EN18120303	04-07-2018	TE Compl Sem I
868	2020.21	Karan Deepak Gadale	EN18166433	10-07-2018	TE Compl Sem I
869	2020.21	Samarth Sanjay Gaikwad	EN18116364	04-07-2018	TE Compl Sem I
870	2020.21	Siddhesh Sandesh Gaikwad	EN18169490	21/07/2018	TE Compl Sem I
871	2020.21	Prashant Vishwanath Galphade	EN18208737	22/07/2018	TE Compl Sem I
872	2020.21	Omkar Bandu Godham	EN18132459	18/07/2018	TE Compl Sem I
873	2020.21	Aditya Devidas Jadhavar	EN18180131	19/07/2018	TE Compl Sem I
874	2020.21	Hussain Hozefa Rangwala	EN18139867	2018-2019	TE Compl Sem I
875	2020.21	Abhishek Chandrakant Jadhav	EN18161401	22/07/2018	TE Compl Sem I
876	2020.21	Vaibhav Raosaheb Jogdand	EN18256573	2018-2019	TE Compl Sem I
877	2020.21	Atharv Santosh Joshi	EN18181736	04-07-2018	TE Compl Sem I
878	2020.21	Ruturaj Suryakant Jugdar	EN18195546	20/07/2018	TE Compl Sem I
879	2020.21	Jyoti Prakash Singh	EN18207598	2018-2019	TE Compl Sem I
880	2020.21	Dattaram Mahadev Kajrekar	EN18177891	21/07/2018	TE Compl Sem I
881	2020.21	Dipti Sanjay Kale	EN18175992	21/07/2018	TE Compl Sem I
882	2020.21	Kalpna Kumari	EN18253665	28/08/2018	TE Compl Sem I
883	2020.21	Kalyani Sunil Chopade	EN18162568	19/07/2018	TE Compl Sem I
884	2020.21	Sanket Uttam Kamble	EN18213861	2018-2019	TE Compl Sem I
885	2020.21	Manoj Kakasaheb Kamthe	EN18124200	15/07/2018	TE Compl Sem I
886	2020.21	Ajaykumar Rashminbhai Khambhayta	EN18263253	28/08/2018	TE Compl Sem I
887	2020.21	Soham Rahul Kamthe	EN18174301	17/07/2018	TE Compl Sem I
888	2020.21	Samreen Murtuz Karajagi	EN18205719	19/07/2018	TE Compl Sem I



889	2020.21	Swaraj Ashok Kokate	EN18168794	29/08/2018	TE Compl Sem I
890	2020.21	Rushikesh Baban Lokhande	EN18160014	20/07/2018	TE Compl Sem I
891	2020.21	Nitin Nagendra Mishra	EN18133856	28/08/2018	TE Compl Sem I
892	2020.21	Rahul Kapuraram Mali	EN18138970	18/07/2018	TE Compl Sem I
893	2020.21	Nazia	EN18127287	2018-2019	TE Compl Sem I
894	2020.21	Faisal Ahmed Momin	EN18133869	20/07/2018	TE Compl Sem I
895	2020.21	Sohail Shahabuddin Mujawar	EN18201161	29/08/2018	TE Compl Sem I
896	2020.21	Mahendra Harke Namrata	EN18233349	19/07/2018	TE Compl Sem I
897	2020.21	Nandini Anand Lavale	EN18126441	29/08/2018	TE Compl Sem I
898	2020.21	Yash Vijay Nimbalkar	EN18108246	20/07/2018	TE Compl Sem I
899	2020.21	Omkar Umesh Utekar	EN18119741	29/08/2018	TE Compl Sem I
900	2020.21	Aishwarya Ramesh Patil	EN18150676	28/08/2018	TE Compl Sem I
901	2020.21	Bhavesh Hemant Pawar	EN18159965	20/07/2018	TE Compl Sem I
902	2020.21	Mansi Sanjay Pawar	EN18213456	18/07/2018	TE Compl Sem I
903	2020.21	Pushkar Devdatta Rahane	EN18193210	29/08/2018	TE Compl Sem I
904	2020.21	Pravin Navnath Payghan	EN18146050	18/07/2018	TE Compl Sem I
905	2020.21	Abhijeet Vajjnath Pitlewad	EN18115910	12-07-2018	TE Compl Sem I
906	2020.21	Pratima Nandkumar Gaikwad	EN18136321	03-07-2018	TE Compl Sem I
907	2020.21	Pushkar Mahajan	EN18103190	21/07/2018	TE Compl Sem I
908	2020.21	Risha Sharad Chandra Bareria	EN18248768	28/08/2018	TE Compl Sem I
909	2020.21	Ankita Balwant Rode	EN18122043	21/07/2018	TE Compl Sem I
910	2020.21	Sandesh Sunil Khore	EN18136733	29/08/2018	TE Compl Sem I
911	2020.21	Shubham Rajesh Sarode	EN18126461	21/07/2018	TE Compl Sem I
912	2020.21	Zoha Sameer Sayyed	EN18157333	19/07/2018	TE Compl Sem I
913	2020.21	Nishid Anil Walde	SOE1704148	26/07/2017	TE Compl Sem I
914	2020.21	Vinayak Thube	EN18121038	2018-2019	TE Compl Sem I
915	2020.21	Kunal Sampat Chavare	19021011BE180	22/08/2019	TE Compl Sem I
916	2020.21	Priyanka Bhagwan Chaudhari	SOE1704588	19/08/2017	TE MechI Sem I
917	2020.21	Saqib Jawed	20011011BE335	18/01/2021	TE MechI Sem I
918	2020.21	Shoeb Mahaboob Shaikh	20011011BE661	02-09-2021	TE MechI Sem I
919	2020.21	Mayur Diliprao Durge	19031021BE14		TE MechI Sem I
920	2020.21	Avinash Rajkumar Biradar	SOE1603362	02-08-2016	TE MechI Sem I
921	2020.21	Abhay Manohar Chinewar	SOE1704238	2018-2019	TE MechI Sem I
922	2020.21	Vaibhav Laxman Choudhari	SOE1704263	28/07/2017	TE MechI Sem I
923	2020.21	Rushikesh Girish Dolas	SOE1704237	28/07/2017	TE MechI Sem I
924	2020.21	Jaywant Vasudev Dode	SOE1704093	26/07/2017	TE MechI Sem I
925	2020.21	Saurabh Ankush Kamble	SOE1704091	26/07/2017	TE MechI Sem I
926	2020.21	Kartik Sanjeev Samanpelliwar	SOE1704246	28/07/2017	TE MechI Sem I
927	2020.21	Shounaq Niteen Pandit	SOE1704631	2019-2020	TE MechI Sem I
928	2020.21	Hrushikesh Ganesh Raut	SOE1704222	2019-2020	TE MechI Sem I
929	2020.21	Suhel Iqbal Sanade	SOE1704273	28/07/2017	TE MechI Sem I
930	2020.21	Sujit Sudhakar Jogi	SOE1704178	2018-2019	TE MechI Sem I
931	2020.21	Vishal Nivrutti Vaje	SOE1704150	27/07/2017	TE MechI Sem I
932	2020.21	Aditya Priyadarshi	EN18266907	29/08/2018	TE MechI Sem I
933	2020.21	Ajay Mahadeo Dagade	EN18146230	19/07/2018	TE MechI Sem I
934	2020.21	Anurag Krishnan Namboodiri	EN18164395	18/07/2018	TE MechI Sem I
935	2020.21	Atharva Surendra Bhagwat	EN18130895	21/07/2018	TE MechI Sem I



936	2020.21	Brajmohansingh Brajendra Singh Bhadori	EN18259190	28/08/2018	TE MechI Sem I
937	2020.21	Yashraj Sudhakar Bhilare	EN18158543	05-07-2018	TE MechI Sem I
938	2020.21	Abhijeet Sudhakar Chavan	EN18153206	21/07/2018	TE MechI Sem I
939	2020.21	Varad Rajesh Dange	EN18146718	12-07-2018	TE MechI Sem I
940	2020.21	Rajdeep Sapath Das	EN18110774	21/07/2018	TE MechI Sem I
941	2020.21	Shreyash Satish Dasai	EN18104273	20/07/2018	TE MechI Sem I
942	2020.21	Pramod Kalidasrao Dhage	EN18244297	22/07/2018	TE MechI Sem I
943	2020.21	Sarthak Binalkumar Dharmik	EN18263244	28/08/2018	TE MechI Sem I
944	2020.21	Yash Dilip Dondal	EN18147493	21/07/2018	TE MechI Sem I
945	2020.21	Gautam Shyamashray Yadav	EN18200587	29/08/2018	TE MechI Sem I
946	2020.21	Rohit Ravindrakumar Gawade	EN18152658	16/07/2018	TE MechI Sem I
947	2020.21	Karan Ajit Ghanwat	EN18191175	05-07-2018	TE MechI Sem I
948	2020.21	Gitesh Satish Wankhede	EN18192087	19/07/2018	TE MechI Sem I
949	2020.21	Shrinivas Balaji Gore	EN18242699	14/07/2018	TE MechI Sem I
950	2020.21	Abhishek Arun Joshi	EN18174036	04-07-2018	TE MechI Sem I
951	2020.21	Sameer Arvind Jumle	EN18142321	19/07/2018	TE MechI Sem I
952	2020.21	Karandeep Singh Bagga	EN18185563	29/08/2018	TE MechI Sem I
953	2020.21	Kunal Anant Khandagale	EN18245194	22/07/2018	TE MechI Sem I
954	2020.21	Abhishek Vijay Kumbhar	EN18165320	2019-2020	TE MechI Sem I
955	2020.21	Adesh Henry Lall	EN18191717	20/07/2018	TE MechI Sem I
956	2020.21	Sanket Chandrakant Londhe	EN18177968	13/07/2018	TE MechI Sem I
957	2020.21	Mahith Manikandan Mudaliyar	EN18123131	2018-2019	TE MechI Sem I
958	2020.21	Fahad Abdul Khalek Mohammed	EN18186778	18/07/2018	TE MechI Sem I
959	2020.21	Pravin Bhaskar Moholkar	EN18153023	20/07/2018	TE MechI Sem I
960	2020.21	Vishal Ravindra Musmade	EN18187696	2018-2019	TE MechI Sem I
961	2020.21	Aditya Santosh Narke	EN18156165	17/07/2018	TE MechI Sem I
962	2020.21	Pramod Ramakant Nimbalkar	EN18194914	17/07/2018	TE MechI Sem I
963	2020.21	Sanket Ravindra Padir	EN18119403	19/07/2018	TE MechI Sem I
964	2020.21	Parth Bhau Dabhekar	EN18265405	28/08/2018	TE MechI Sem I
965	2020.21	Dhiraj Pravin Patil	EN18171118	19/07/2018	TE MechI Sem I
966	2020.21	Harshal Jijabrao Patil	EN18102478	06-07-2018	TE MechI Sem I
967	2020.21	Mukund Sanjay Patil	EN18175285	09-07-2018	TE MechI Sem I
968	2020.21	Rohit Shidhesh Phulari	EN18175078	12-07-2018	TE MechI Sem I
969	2020.21	Atharva Yogesh Pol	EN18119605	19/07/2018	TE MechI Sem I
970	2020.21	Pankaj Pushkarsingh Rawat	EN18135450	21/07/2018	TE MechI Sem I
971	2020.21	Ganesh Anandrao Sawant	EN18162720	20/07/2018	TE MechI Sem I
972	2020.21	Shalin Yogiraj Patekar	EN18246503	19/07/2018	TE MechI Sem I
973	2020.21	Yashraj Pratap Shinde	EN18184612	15/07/2018	TE MechI Sem I
974	2020.21	Suryakant Singh	EN18255100	28/08/2018	TE MechI Sem I
975	2020.21	Tejas Dashrath More	EN18120993	29/08/2018	TE MechI Sem I
976	2020.21	Mukul Vilasrao Jagtap	SOE1300546	02-08-2013	TE MechI Sem I
977	2020.21	Harish Suresh Menon	15111011BE202	09-10-2020	TE MechI Sem I
978	2020.21	Shreyash Prakash Dumbre	SOE1502415	12-01-2016	TE MechI Sem I
979	2020.21	Chaitanya Hanumant Desai	SOE1603531	06-08-2016	TE MechI Sem I
980	2020.21	Ashutosh Rajendra Chikhale	SOE1603509	05-08-2016	TE MechI Sem I
981	2020.21	Gangesh Mahendra Dhuri	SOE1603151	28/07/2016	TE MechI Sem I
982	2020.21	Aniket Ujwalrao Kambe	SOE1603231	17/07/2018	TE MechI Sem I



983	2020.21	Krishna Chandrakant Bandekar	SOE1603322	02-08-2016	TE MechI Sem I
984	2020.21	Mohit Sohan Bhat	SOE1603172	22/07/2016	TE MechI Sem I
985	2020.21	Hemant Dinesh Pardeshi	SOE1603402	03-08-2016	TE MechI Sem I
986	2020.21	Prashant Shashikant Chaudhary	SOE1603406	03-08-2016	TE MechI Sem I
987	2020.21	Saurabh Saurabh Kumar	SOE1603540	29/08/2016	TE MechI Sem I
988	2020.21	Shubham Anupkumar Chavan	SOE1603860		TE MechI Sem I
989	2020.21	Atharva Dinkarrao Thombre	SOE1704061	25/07/2017	TE MechI Sem I
990	2020.21	Avinash Premprakash Thanvi	SOE1704352	06-08-2017	TE MechI Sem I
991	2020.21	Viraj Gomansinh Solanki	SOE1704618	12-09-2017	TE MechI Sem I
992	2020.21	Venkateshan Manoharan	EN18120722	28/08/2018	TE MechI Sem I
993	2020.21	Vishwajeet Abhay More	EN18176057	12-07-2018	TE MechI Sem I
994	2020.21	Rohit Yashwant Yadav	EN18183020	2018-2019	TE MechI Sem I
995	2020.21	Pravin Hanumant Sangve	EN18195359	21/07/2018	TE MechI Sem I
996	2020.21	Aditya Mahavir Patni	19011021BE164	2019-2020	TE MechI Sem I
997	2020.21	Tushar Kacharu Ajabe	19011021BE154	2019-2020	TE MechI Sem I
998	2020.21	Ajay Mukesh Chaudhary	19011021BE146	2019-2020	TE MechI Sem I
999	2020.21	Harshal Vinod Amrutkar	19021021BE100	2019-2020	TE MechI Sem I
1000	2020.21	Aniket Udhav Mungare	19051021BE137	2019-2020	TE MechI Sem I
1001	2020.21	Atharva Sanjay Tare	19081021BE131	30/08/2019	TE MechI Sem I
1002	2020.21	Rushikesh Prakash Bagul	19011021BE67	08-11-2019	TE MechI Sem I
1003	2020.21	Rushikesh Prabhakar Bangar	19071021BE59	08-10-2019	TE MechI Sem I
1004	2020.21	Sanket Sanjay Bhalerao	19031021BE133	30/08/2019	TE MechI Sem I
1005	2020.21	Sanju Mohan Bhagne	19041021BE130	30/08/2019	TE MechI Sem I
1006	2020.21	Prashant Sanjay Bharambe	19021021BE63	2019-2020	TE MechI Sem I
1007	2020.21	Rushikesh Sandeep Bhavsar	19021021BE84	2019-2020	TE MechI Sem I
1008	2020.21	Sagar Kamlesh Bijlani	19011021BE163	31/08/2019	TE MechI Sem I
1009	2020.21	Nikhil Sanjay Birajdar	190101021BE119	24/08/2019	TE MechI Sem I
1010	2020.21	Tejas Kishor Borase	19021021BE157	31/08/2019	TE MechI Sem I
1011	2020.21	Devanand Balasaheb Borhade	19011021BE158	2019-2020	TE MechI Sem I
1012	2020.21	Bapu Dattatray Borude	19021021BE118	2019-2020	TE MechI Sem I
1013	2020.21	Chetan Ganesh Burge	19021021BE147	2019-2020	TE MechI Sem I
1014	2020.21	Rohit Tanaji Chaudhari	19011021BE127	30/08/2019	TE MechI Sem I
1015	2020.21	Rutik Suhas Chaudhari	19021021BE129	2019-2020	TE MechI Sem I
1016	2020.21	Atharv Vijay Chavan	19031021BE142	31/08/2019	TE MechI Sem I
1017	2020.21	Vivek Shantinath Chavan	19011021BE89	23/08/2019	TE MechI Sem I
1018	2020.21	Vishal Vitthal Choudhari	19021021BE150	31/08/2019	TE MechI Sem I
1019	2020.21	Nikhil Sanjay Chougale	19011021BE87	2019-2020	TE MechI Sem I
1020	2020.21	Vijay Narayan Desai	190101021BE106	24/08/2019	TE MechI Sem I
1021	2020.21	Shivam Pandurang Deshmukh	19011021BE72	2019-2020	TE MechI Sem I
1022	2020.21	Ronak Kailash Dhumal	19011021BE81	2019-2020	TE MechI Sem I
1023	2020.21	Rajesh Pradip Gahiwal	19021021BE145	2019-2020	TE MechI Sem I
1024	2020.21	Saurav Nyayakar Gaikwad	19031021BE66	08-11-2019	TE MechI Sem I
1025	2020.21	Mahadev Ramesh Gawade	200101021BE102	2019-2020	TE MechI Sem I
1026	2020.21	Gaurav Vilas Hirdekar	19011021BE140	31/08/2019	TE MechI Sem I
1027	2020.21	Mayur Shubhash Ichake	19011021BE138	30/08/2019	TE MechI Sem I
1028	2020.21	Balaji Ramchandra Ighare	19071021BE89	23/08/2019	TE MechI Sem I
1029	2020.21	Abhishek Ishwardas Ingle	19011021BE128	30/08/2019	TE MechI Sem I





1030	2020.21	Jaykumar Sachin Jadhav	190101021BE167	2019-2020	TE MechI Sem I
1031	2020.21	Nikhil Netaji Jadhav	190101021BE107	24/08/2019	TE MechI Sem I
1032	2020.21	Swarupa Deepak Kalambe	19011021BE112	2019-2020	TE MechI Sem I
1033	2020.21	Abhishek Suresh Kalbhor	19011021BE96	23/08/2019	TE MechI Sem I
1034	2020.21	Animesh Ashok Kamble	19031021BE76	2019-2020	TE MechI Sem I
1035	2020.21	Rajshree Sanjay Kamble	19051021BE80	22/08/2019	TE MechI Sem I
1036	2020.21	Shankar Tukaram Kamble	19031021BE85	2019-2020	TE MechI Sem I
1037	2020.21	Omkar Kisan Khalate	190101021BE136	30/08/2019	TE MechI Sem I
1038	2020.21	Ganesh Pralhad Khankal	19051021BE105	2019-2020	TE MechI Sem I
1039	2020.21	Aditya Vilas Kolhe	19021021BE141	2019-2020	TE MechI Sem I
1040	2020.21	Onkar Vijay Lokhande	19061021BE143	2019-2020	TE MechI Sem I
1041	2020.21	Rohit Ramesh Nagi	19031021BE58	08-10-2019	TE MechI Sem I
1042	2020.21	Aditya Balaji Mamulwar	19051021BE162	2019-2020	TE MechI Sem I
1043	2020.21	Rohit Dada Mandge	19011021BE110	24/08/2019	TE MechI Sem I
1044	2020.21	Mangesh Bajirao Gawali	190101021BE139	2019-2020	TE MechI Sem I
1045	2020.21	Manish Kumar Ram	19011021BE173	2019-2020	TE MechI Sem I
1046	2020.21	Ajay Datta Mare	19031021BE126	2018-2019	TE MechI Sem I
1047	2020.21	Noor E Mohammad Yasin Jamadar	19011021BE101	2019-2020	TE MechI Sem I
1048	2020.21	Harshal Vitthal Bade	SOE1704630	28/08/2017	TE MechI Sem I
1049	2020.21	Saurabh Sunil Balghare	SOE1704105	26/07/2017	TE MechI Sem I
1050	2020.21	Nikhil Vishwas Bhor	SOE1704208	27/07/2017	TE MechI Sem I
1051	2020.21	Prajwal Chandrashekhar Birajdar	SOE1704255	28/07/2017	TE MechI Sem I
1052	2020.21	Hanumant Sudhakar Bondre	SOE1704122	26/07/2017	TE MechI Sem I
1053	2020.21	Gourab Bhaskar Ghoshal	SOE1704621	28/08/2017	TE MechI Sem I
1054	2020.21	Ashutosh Sandhya Kulkarni	SOE1704170	27/07/2017	TE MechI Sem I
1055	2020.21	Pradip Baburao Mangrile	SOE1704241	28/07/2017	TE MechI Sem I
1056	2020.21	Shijo John Mathew	SOE1704355	06-08-2017	TE MechI Sem I
1057	2020.21	Shahid Valimohammad Mujawar	SOE1704143	26/07/2017	TE MechI Sem I
1058	2020.21	Aniket Bhagwat Nagawade	SOE1704207	27/07/2017	TE MechI Sem I
1059	2020.21	Soumya Ranjan Panda	SOE1704229	28/07/2017	TE MechI Sem I
1060	2020.21	Atul Anil Pandhare	SOE1704270	28/07/2017	TE MechI Sem I
1061	2020.21	Ishwardas Appasaheb Pathade	SOE1704095	26/07/2017	TE MechI Sem I
1062	2020.21	Sudarshan Anurath Shinde	SOE1704052	25/07/2017	TE MechI Sem I
1063	2020.21	Akash Jagannath Shinde	SOE1704128	26/07/2017	TE MechI Sem I
1064	2020.21	Kunal Anil Shirode	SOE1704185	27/07/2017	TE MechI Sem I
1065	2020.21	Simran J Joslal	SOE1704160	27/07/2017	TE MechI Sem I
1066	2020.21	Swami Rajesh Khirwadkar	SOE1704132	26/07/2017	TE MechI Sem I
1067	2020.21	Ishan . Darji	SEP1500385	07-10-2018	TE MechI Sem I
1068	2020.21	Amol Pandit Gore	SOE1502689	14/07/2015	TE MechI Sem I
1069	2020.21	Swaraj Raju Pakhare	19021021BE79	22/08/2019	TE MechI Sem I
1070	2020.21	Mandar Krishn Pande	19011021BE156	31/08/2019	TE MechI Sem I
1071	2020.21	Prathamesh Sunil Patil Bende	19011021BE121	24/08/2019	TE MechI Sem I
1072	2020.21	Manohar Raju Patil	19021021BE149	2019-2020	TE MechI Sem I
1073	2020.21	Nayan Sunil Patil	19021021BE159	2019-2020	TE MechI Sem I
1074	2020.21	Omkar Pandurang Patil	19011021BE144	31/08/2019	TE MechI Sem I
1075	2020.21	Shubham Subhash Patil	19011021BE166	31/08/2019	TE MechI Sem I
1076	2020.21	Shubham Rajendra Pawar	19011021BE104	24/08/2019	TE MechI Sem I



1077	2020.21	Pranav Sanjay Potdar	19021021BE94	2019-2020	TE MechI Sem I
1078	2020.21	Rohit Sunil Punde	19011021BE108	2019-2020	TE MechI Sem I
1079	2020.21	Prashant Sanjay Rahane	190101021BE120	2019-2020	TE MechI Sem I
1080	2020.21	Omkar Chandrakant Rangade	19011021BE132	2019-2020	TE MechI Sem I
1081	2020.21	Prajwal Dnyaneshwar Rohamare	19021021BE172	2019-2020	TE MechI Sem I
1082	2020.21	Aditya Bapurao Rukhe	190101021BE165	2019-2020	TE MechI Sem I
1083	2020.21	Pawan Thansing Sable	19091021BE68	08-11-2019	TE MechI Sem I
1084	2020.21	Pratik Narayan Salunkhe	190101021BE95	2019-2020	TE MechI Sem I
1085	2020.21	Vishal Kumar Saroj	19011021BE103	24/08/2019	TE MechI Sem I
1086	2020.21	Anuj Dilip Surpate	19031021BE155	31/08/2019	TE MechI Sem I
1087	2020.21	Pavan Ramesh Sathe	19011021BE153	2019-2020	TE MechI Sem I
1088	2020.21	Saurabh Sanjay Padwal	1901021	2019-2020	TE MechI Sem I
1089	2020.21	Aamir Parvez Shaikh	19011021BE134	2019-2020	TE MechI Sem I
1090	2020.21	Zuber Javed Shaikh	19011021BE114	24/08/2019	TE MechI Sem I
1091	2020.21	Mayur Anilrao Shamkuwar	19031021BE97	23/08/2019	TE MechI Sem I
1092	2020.21	Maaz Shaheed Shariff	19011021BE115	24/08/2019	TE MechI Sem I
1093	2020.21	Vaishnavi Dattatray Shelar	19021021BE116	24/08/2019	TE MechI Sem I
1094	2020.21	Shubham Aba Borse	19021021BE148	2019-2020	TE MechI Sem I
1095	2020.21	Shubham Anil Deshmukh	1901021BE168	2019-2020	TE MechI Sem I
1096	2020.21	Shubham Jitendra Bhosle	19111021BE83	2019-2020	TE MechI Sem I
1097	2020.21	Sakshi Venkat Sidha	19011021BE171	09-01-2019	TE MechI Sem I
1098	2020.21	Darshan Kiran Solanki	19011021BE98	23/08/2019	TE MechI Sem I
1099	2020.21	Suhail Nayem Shaikh	19011021BE135	2019-2020	TE MechI Sem I
1100	2020.21	Dharmesh Jethmal Sutar	19011021BE111	24/08/2019	TE MechI Sem I
1101	2020.21	Akshay Sandip Thoke	19011021BE117	2019-2020	TE MechI Sem I
1102	2020.21	Jitesh Madhukar Thombre	190101021BE160	2019-2020	TE MechI Sem I
1103	2020.21	Ameya Rajendra Tidke	19021021BE124	29/08/2019	TE MechI Sem I
1104	2020.21	Sandesh Rajesh Tribhuvan	19011021BE152	2019-2020	TE MechI Sem I
1105	2020.21	Sarthak Rajesh Umak	19021021BE125	29/08/2019	TE MechI Sem I
1106	2020.21	Vishal Kailas Patil	19021021BE86	2019-2020	TE MechI Sem I
1107	2020.21	Harshal Valmik Wakehaure	19021021BE109	2019-2020	TE MechI Sem I
1108	2020.21	Jayesh Sanjeev Wangar	19081021BE161	31/08/2019	TE MechI Sem I
1109	2020.21	Rohit Nandkishor Yerojwar	19021021BE75	2019-2020	TE MechI Sem I
1110	2020.21	Yuvraj Rajendra Kashyap	19011021BE174	09-09-2019	TE MechI Sem I
1111	2020.21	Gaurav Pandurang Asane	19021021BE70	08-11-2019	TE MechI Sem I
1112	2020.21	Suraj Sheshrao Bangar	19061021BE88	23/08/2019	TE MechI Sem I
1113	2020.21	Kunal Dadaji Biraris	19021021BE99	2019-2020	TE MechI Sem I
1114	2020.21	Adesh Nanasaheb Borse	190101021BE57	2019-2020	TE MechI Sem I
1115	2020.21	Ganesh Hrudaynath Dixit	19021021BE69	2019-2020	TE MechI Sem I
1116	2020.21	Sayali Ambadas Ighe	19051021BE64	2019-2020	TE MechI Sem I
1117	2020.21	Niranjan Rajesh Jachak	190101021BE62	08-10-2019	TE MechI Sem I
1118	2020.21	Kishor Dhanappa Koli	19081021BE151	2019-2020	TE MechI Sem I
1119	2020.21	Tanmay Dilip Magar	19021021BE91	23/08/2019	TE MechI Sem I
1120	2020.21	Spandan Devendra Shimpi	19021021BE71	08-12-2019	TE MechI Sem I
1121	2020.21	Deepak Bahirath Shinde	19031021BE169	2019-2020	TE MechI Sem I
1122	2020.21	Pratik Annasaheb Sonawane	19021021BE61	08-10-2019	TE MechI Sem I
1123	2020.21	Tanmay Rajendra Sonawane	19021021BE82	2019-2020	TE MechI Sem I



1124	2020.21	Harshad Raja Thorat	19031021BE93	2019-2020	TE MechI Sem I
1125	2020.21	Suraj Manoj Thorat	19021021BE92	23/08/2019	TE MechI Sem I
1126	2020.21	Rajesh Vasant Surle	SOE1704243	28/07/2017	TE MechI Sem I
1127	2020.21	Veerakumar Bhimagouda Patil	SOE1704279	28/07/2017	TE MechI Sem I
1128	2020.21	Shrikant Babu Chikhale	SOE1805042	28-07-2017	TE MechI Sem I
1129	2020.21	Umesh Nitin Dudam	SOE1805130	2018-2019	TE MechI Sem I
1130	2020.21	Akshay Jitendrasing Girase	SOE1805025	2018-2019	TE MechI Sem I
1131	2020.21	Ashutosh Ankush Kadam	SOE1805208	2018-2019	TE MechI Sem I
1132	2020.21	Prathamesh Sunil Mahale	SOE1805084	2018-2019	TE MechI Sem I
1133	2020.21	Onkar Ashok Mali	SOE1805097	2018-2019	TE MechI Sem I
1134	2020.21	Nikhil Shravan More	SOE1805158	2018-2019	TE MechI Sem I
1135	2020.21	Mukul Sanjay Pawar	18011021BE9	2018-2019	TE MechI Sem I
1136	2020.21	Chaitali Laxman Sarwar	SOE1805327	2018-2019	TE MechI Sem I
1137	2020.21	Sagar Duryodhan Shinde	SOE1805321	2018-2019	TE MechI Sem I
1138	2020.21	Siddharth Arun Shinde	19011021BE10	2019	TE MechI Sem I
1139	2020.21	Shubham Ravindra Badgujar	SOE1805159	2018-2019	TE MechI Sem I
1140	2020.21	Chakrapani Ashok Thakare	SOE1805296	2018-2019	TE MechI Sem I
1141	2020.21	Hemant Boleshwar Thorat	SOE1805303	2018-2019	TE MechI Sem I
1142	2020.21	Shreyash Sambhaji Vyawahare	SOE1805134	2018-2019	TE MechI Sem I
1143	2020.21	Sumit Sanjay Dhotre	SOE1603566	08-08-2016	TE MechI Sem I
1144	2020.21	Rishikesh Apparao Chakor	SOE1603266	01-08-2016	TE MechI Sem I
1145	2020.21	Akhil	EN18106815	04-07-2018	TE MechI Sem I
1146	2020.21	Aditi Mahesh Salvi	EN18124085	06-07-2018	TE Civil Sem I
1147	2020.21	Snehal Subhash Ghogare	EN18173399	19/07/2018	TE Civil Sem I
1148	2020.21	Dhanashri Subhash Bhujbal	SOE1704298	29/07/2017	TE Civil Sem I
1149	2020.21	Rahul Kalappa Hokrani	EN18237763	22/07/2018	TE Civil Sem I
1150	2020.21	Kiran Kakasaheb Netke	EN18146219	22/07/2018	TE Civil Sem I
1151	2020.21	Manjunath Sharanappa Kurle	EN18143047	07-10-2018	TE Civil Sem I
1152	2020.21	Mihir Dipak Patil	EN18128607	28/08/2018	TE Civil Sem I
1153	2020.21	Ajay Dhanaji Nalawade	EN18115610	21/07/2018	TE Civil Sem I
1154	2020.21	Sushil Hareram Padvi	EN18140703	21/07/2018	TE Civil Sem I
1155	2020.21	Swapnil Sajjan Rawade	EN18242510	21/07/2018	TE Civil Sem I
1156	2020.21	Pratik Prakash Bhalerao	SOE1704120	2019-2020	TE Civil Sem I
1157	2020.21	Akshay Uttam Gaikwad	SOE1704099	26/07/2017	TE Civil Sem I
1158	2020.21	Divyanshu Natthu Ahirrao	EN18198759	20/07/2018	TE Civil Sem I
1159	2020.21	Saurabh Deelip Chavan	SOE1704349	05-08-2017	TE Civil Sem I
1160	2020.21	Pradnya Kalyan Choudhar	SOE1704035	2019-2020	TE Civil Sem I
1161	2020.21	Praveen Sunil Kumar	SOE1704217	27/07/2017	TE Civil Sem I
1162	2020.21	Shreyash Anil Rewatkar	SOE1704239	28/07/2017	TE Civil Sem I
1163	2020.21	Vipul Rajendra Jagtap	SOE1502486		TE Civil Sem I
1164	2020.21	Akshay Bhausahb Gavhane	SOE1704245	28/07/2017	TE Civil Sem I
1165	2020.21	Swapnil Suresh Londhe	SOE1704070	25/07/2017	TE Civil Sem I
1166	2020.21	Zaid Saqlain Shaikh	SOE1704617	28/08/2017	TE Civil Sem I
1167	2020.21	Vidnyan Vijay Walawalkar	EN18207375	21/07/2018	TE Civil Sem I
1168	2020.21	Rahul Siddheswar Aldar	19061041BE47	31/08/2019	TE Civil Sem I
1169	2020.21	Abhishek Jitendra Bendre	19031041BE43	30/08/2019	TE Civil Sem I
1170	2020.21	Fozail Ahmad Khan	SOE1502792	20/09/2016	TE Civil Sem I



1171	2020.21	Parul Vilas Asekar	EN18134486	14/07/2018	TE Civil Sem I
1172	2020.21	Anita Ranganath Bhangare	19041041BE29	08-11-2019	TE Civil Sem I
1173	2020.21	Trupti Tulshiram Bomble	19021041BE34	23/08/2019	TE Civil Sem I
1174	2020.21	Samruddhi Suhas Bulbule	19021041BE46	31/08/2019	TE Civil Sem I
1175	2020.21	Mahesh Ramdas Deshmane	19021041BE31	13/08/2019	TE Civil Sem I
1176	2020.21	Sourav Raju Dhawale	19031041BE30	13/08/2019	TE Civil Sem I
1177	2020.21	Shreya Sarang Girolla	19011041BE52	09-04-2019	TE Civil Sem I
1178	2020.21	Suvarna Eknath Jadhav	19041041BE48	31/08/2019	TE Civil Sem I
1179	2020.21	Kiran Rajendra Jadhav	19011041BE38	24/08/2019	TE Civil Sem I
1180	2020.21	Sanket Sunil Barhate	EN18196989	22/07/2018	TE Civil Sem I
1181	2020.21	Shubham Jagannath Lokhande	190101041BE35	24/08/2019	TE Civil Sem I
1182	2020.21	Devica Raghunath Mohite	19011041BE33	22/08/2019	TE Civil Sem I
1183	2020.21	Aditya Rajendra Nagare	19021041BE32	22/08/2019	TE Civil Sem I
1184	2020.21	Mangesh Kailasrao Naik	19021041BE37	24/08/2019	TE Civil Sem I
1185	2020.21	Swapnil Sanjay Parkhe	190101041BE40	24/08/2019	TE Civil Sem I
1186	2020.21	Vipul Sunil Patil	19051041BE44	31/08/2019	TE Civil Sem I
1187	2020.21	Bhushan Prakash Patil	19011041BE42	30/08/2019	TE Civil Sem I
1188	2020.21	Vaibhav Maruti Patil	190101041BE36	24/08/2019	TE Civil Sem I
1189	2020.21	Dhananjay Subhash Shelar	SOE1603528		TE Civil Sem I
1190	2020.21	Priyanka Sanjay Patil	190101041BE50	09-01-2019	TE Civil Sem I
1191	2020.21	Shaunak Moreshwar Shastri	190111041BE49	31/08/2019	TE Civil Sem I
1192	2020.21	Ritik Rajkumar Bhojar	EN18104658	20/07/2018	TE Civil Sem I
1193	2020.21	Tarachand Balkrishna Shegar	19061041BE41	30/08/2019	TE Civil Sem I
1194	2020.21	Mohini Manaji Suryawanshi	190101041BE45	31/08/2019	TE Civil Sem I
1195	2020.21	Pramod Maruti Jadhav	SEP1600559	08-07-2016	TE Civil Sem I
1196	2020.21	Anup Arun Sutey	SOE1704139	26/07/2017	TE Civil Sem I
1197	2020.21	Prakash Kisan Chature	EN18185655	04-07-2018	TE Civil Sem I
1198	2020.21	Rahul Madhukar Maske	SOE1805245		TE Civil Sem I
1199	2020.21	Siddhesh Sanjay Chavan	EN18128366	15/07/2018	TE Civil Sem I
1200	2020.21	Omkar Harisheandra Batwal	SOE1603202		TE Civil Sem I
1201	2020.21	Dipali Anil Bhangale	EN18147184	06-07-2018	TE Civil Sem I
1202	2020.21	Vishal Dattatray Gaikwad	EN18205967	21/07/2018	TE Civil Sem I
1203	2020.21	Ananya Chattopadhyay	EN18118884	2018-2019	TE ENTC Sem I
1204	2020.21	Anjali Yadav	EN18263365	2018-2019	TE ENTC Sem I
1205	2020.21	Anshu Anil Kumar	SOE1704610	28/08/2017	TE ENTC Sem I
1206	2020.21	Anuja Raju Jadhav	EN14174873	2014	TE ENTC Sem I
1207	2020.21	Vamsikrishna Subbarayudu Avula	EN18116154	2018-2019	TE ENTC Sem I
1208	2020.21	Rohit Rajaram Bagal	EN18205366	20/07/2018	TE ENTC Sem I
1209	2020.21	Pratik Yogesh Baisware	EN18128174	2018-2019	TE ENTC Sem I
1210	2020.21	Abhijeet Vikas Kamble	EN18119067	21/07/2018	TE ENTC Sem I
1211	2020.21	Priyanka Chandrakant Bhute	SOE1704250	28/07/2017	TE ENTC Sem I
1212	2020.21	Kakshil Manish Chandodwala	EN18192245	29/08/2018	TE ENTC Sem I
1213	2020.21	Ravi Sudam Chavan	SOE1704282	29/07/2017	TE ENTC Sem I
1214	2020.21	Chetna Satla	EN18139319	20/07/2018	TE ENTC Sem I
1215	2020.21	Divya Ram Dalvi	19011031BE57	13/08/2019	TE ENTC Sem I
1216	2020.21	Abhishek Jaikant Daulatkar	EN18210645	18/07/2018	TE ENTC Sem I
1217	2020.21	Siddhant Ganesh Desai	19011031BE60	30/08/2019	TE ENTC Sem I



1265	2020.21	Vishal Kumar Shri Rajkumar Yadav	SOE1704612	28/08/2017	BE Compl Sem I
1266	2020.21	Firosh Vasudevan N	SOE1704230	28/07/2017	BE Compl Sem I
1267	2020.21	Akash Santosh Chaudhari	SOE1704156	27/07/2017	BE Compl Sem I
1268	2020.21	Yash Vijay Patil	SOE1704197	27/07/2017	BE Compl Sem I
1269	2020.21	Yogesh Sanjeevrao Bhosle	SOE1603170	17/05/2018	BE Compl Sem I
1270	2020.21	Adesh Nandkishor Kolte	SOE1704528	2018-2019	BE Compl Sem I
1271	2020.21	Geetanjali Anilkumar Pandey	SOE1704144	26/07/2017	BE Compl Sem I
1272	2020.21	Mrunal Suresh Rao Saraf	SOE1704523	18/08/2017	BE Compl Sem I
1273	2020.21	Vaishnavi Gajanan Chaugule	SOE1704645	29/08/2017	BE Compl Sem I
1274	2020.21	Rohit Ramesh Ganguli	12011011BE665	23/03/2021	BE Compl Sem I
1275	2020.21	Pranali Anil Patil	SOE1704461	17/08/2017	BE Compl Sem I
1276	2020.21	Akshay Prabhakar Mahalle	SOE1603535		BE Compl Sem I
1277	2020.21	Shavez Altaf Shaikh	SOE1704474	17/08/2017	BE Compl Sem I
1278	2020.21	Shubham Ramsahay Gour	SOE1704468	17/08/2017	BE Compl Sem I
1279	2020.21	Supriya Sanganbasappa Kiwade	SOE1704413	16/08/2017	BE Compl Sem I
1280	2020.21	Saloni Makarand Dangre	SOE1704338	05-08-2017	BE Compl Sem I
1281	2020.21	Akshay Pradeep Chavan	SOE1704667		BE Compl Sem I
1282	2020.21	Aditya Anant Deo	SOE1704031	25/07/2017	BE Compl Sem I
1283	2020.21	Mahendra Sanjay Mahajan	SOE1704649	29/08/2017	BE Compl Sem I
1284	2020.21	Snehal Shashikant More	15011011BE206	11-10-2020	BE Compl Sem I
1285	2020.21	Pratik Subhash Nirmale	SOE1502628		BE Compl Sem I
1286	2020.21	Sonam Shaligram Patil	SOE1603949		BE Compl Sem I
1287	2020.21	Onkar Mahadev Jagtap	SOE1502418		BE Compl Sem I
1288	2020.21	Ruchin Dhama	SOE1704168	27/07/2017	BE Compl Sem I
1289	2020.21	Abhishek Kumar Jaiswal	SOE1401922		BE Compl Sem I
1290	2020.21	Sandhyarani Wamanrao Shinde	SOE1603998		BE Compl Sem I
1291	2020.21	Sahil Virender Dhankhar	SOE1704042	25/07/2017	BE Compl Sem I
1292	2020.21	Maithili Nandkumar Gayli	SOE1704074	25/07/2017	BE Compl Sem I
1293	2020.21	Mona Sunil Sinha	SOE1704601	28/08/2017	BE Compl Sem I
1294	2020.21	Ritesh Naresh Patidar	SOE1704636	2018-2019	BE Compl Sem I
1295	2020.21	Pragati Anant Tamboli	SOE1805039	2018-2019	BE Compl Sem I
1296	2020.21	Shivani Mohan Chougule	SOE1704646	29/08/2017	BE Compl Sem I
1297	2020.21	Vaibhav Ravindra Patil	SOE1704256	28/07/2017	BE Compl Sem I
1298	2020.21	Vishal Kumar Singh	20011011BE208	15/12/2020	BE Compl Sem I
1299	2020.21	Darshan Sanjaybhai Ganatra	SOE1704651	29/08/2017	BE Compl Sem I
1300	2020.21	Rahul Shahaji Takalkar	SOE1805061	2019-2020	BE Compl Sem I
1301	2020.21	Swapnil Dnyaneshwar Nangare	SOE1805085	2019-2020	BE Compl Sem I
1302	2020.21	Chaitanya Prabhakar Ghadling	SOE1704098	26/07/2017	BE Compl Sem I
1303	2020.21	Shubham Dattatray Suryavanshi	SOE1805056		BE Compl Sem I
1304	2020.21	Shailendra Singh Gujar	SOE1704251	28/07/2017	BE Compl Sem I
1305	2020.21	Suraj Vyankat Pethekar	SOE1805055		BE Compl Sem I
1306	2020.21	Nikita Dattatray Ingale	SOE1704089	25/07/2017	BE Compl Sem I
1307	2020.21	Amit Vilas Lokre	SOE1805064		BE Compl Sem I
1308	2020.21	Samidha Madhav Jadhav	SOE1704278	28/07/2017	BE Compl Sem I
1309	2020.21	Poonam Sandeep Bankar	SOE1805043	2018-2019	BE Compl Sem I
1310	2020.21	Harshada Ashok Mohite	SOE1805122		BE Compl Sem I
1311	2020.21	Tanisha Kamlesh Jaiswal	SOE1704324	31/07/2017	BE Compl Sem I



1312	2020.21	Mahesh Dattatray Dhumal	SOE1502960	11-08-2015	BE Compl Sem I
1313	2020.21	Divyanshu Anantram Tripathi	SOE1805019		BE Compl Sem I
1314	2020.21	Sangram Sudam Thorat	SOE1805028		BE Compl Sem I
1315	2020.21	Mahesh Rajaram Badhe	SOE1704254	28/07/2017	BE Compl Sem I
1316	2020.21	Akshay Dnyandeo Karale	SOE1704163	27/07/2017	BE Compl Sem I
1317	2020.21	Pratik Laxman Trimbake	SOE1805104		BE Compl Sem I
1318	2020.21	Kalyani Laxman Kasar	SOE1704071	25/07/2017	BE Compl Sem I
1319	2020.21	Omkar Dattatray Gaikwad	SOE1805307	2018-2019	BE Compl Sem I
1320	2020.21	Vrushali Santosh Kolte	SOE1704140	26/07/2017	BE Compl Sem I
1321	2020.21	Siddhi Santosh Salunke	SOE1805281	2018-2019	BE Compl Sem I
1322	2020.21	Geeta Brijlal Kotwani	SOE1704343	05-08-2017	BE Compl Sem I
1323	2020.21	Rutuja Ramesh Patil	SOE1805187	08-06-2018	BE Compl Sem I
1324	2020.21	Shubham Kumar	SOE1704218	01-03-2018	BE Compl Sem I
1325	2020.21	Shivam Anand Ghorpade	SOE1603823	02-09-2016	BE Compl Sem I
1326	2020.21	Mayur Sanjay Talole	SOE1805153	07-09-2018	BE Compl Sem I
1327	2020.21	Shikha Anand Kushwaha	SOE1704640	28/08/2017	BE Compl Sem I
1328	2020.21	Dipak Suresh Khetta	SOE1805263		BE Compl Sem I
1329	2020.21	Shreya Shivajirao Lad	SOE1704337	19/06/2018	BE Compl Sem I
1330	2020.21	Aniket Lalasaheb Bhosale	18011011BE24		BE Compl Sem I
1331	2020.21	Forum Suryakant Makwana	SOE1704635	28/08/2017	BE Compl Sem I
1332	2020.21	Rahul Madhukar Ahire	SOE1805198		BE Compl Sem I
1333	2020.21	Sudarshan Krishna Jagdale	SOE1805224	2018-2019	BE Compl Sem I
1334	2020.21	Pratiksha Pralhad Survase	SOE1805250	2018-2019	BE Compl Sem I
1335	2020.21	Sayali Dhanraj Mhaske	SOE1704335	05-08-2017	BE Compl Sem I
1336	2020.21	Shivam Mishra	SOE1704069	25/07/2017	BE Compl Sem I
1337	2020.21	Vaishali Sunil Kale	SOE1805311		BE Compl Sem I
1338	2020.21	Kshitij Kalash Motke	SOE1704136	26/07/2017	BE Compl Sem I
1339	2020.21	Meghana Mukund Rikibe	SOE1805285		BE Compl Sem I
1340	2020.21	Sampada Ashok Pathare	SOE1805279		BE Compl Sem I
1341	2020.21	Ritesh Ramesh Hajare	SOE1603826	02-09-2016	BE Compl Sem I
1342	2020.21	Gopal Rameshwar Mule	SOE1603333		BE Compl Sem I
1343	2020.21	Pooja Sanjay Gupta	SOE1805196		BE Compl Sem I
1344	2020.21	Saurabh Shivaji Nangare	SOE1704289	29/07/2017	BE Compl Sem I
1345	2020.21	Shraddha Ravindra Khandre	SOE1805095	08-07-2018	BE Compl Sem I
1346	2020.21	Pranav Kailash Shinde	SOE1704619	06-08-2017	BE Compl Sem I
1347	2020.21	Sadichha Sarjerao Khedkar	SOE1805276		BE Compl Sem I
1348	2020.21	Sanjay Naresh Parmar	SOE1704064	25/07/2017	BE Compl Sem I
1349	2020.21	Aishwarya Chandrashekhar Munuswamy	SOE1805133	2018-2019	BE Compl Sem I
1350	2020.21	Abhishek Yuvaraj Patil	SOE1704244	28/07/2017	BE Compl Sem I
1351	2020.21	Shruti Laxman Khaire	SOE1805306		BE Compl Sem I
1352	2020.21	Pushpak Sharad Patil	SOE1704204	27/07/2017	BE Compl Sem I
1353	2020.21	Swapnali Sampat Kamble	SOE1805195		BE Compl Sem I
1354	2020.21	Swati Balyan	SOE1704153	27/07/2017	BE Compl Sem I
1355	2020.21	Shivaraya Shivalingappa Patil	SOE1704214	27/07/2017	BE Compl Sem I
1356	2020.21	Rakshanda Bharat Kapoor	SOE1805150		BE Compl Sem I
1357	2020.21	Rohan Vivek Sambhudas	SOE1704141	26/07/2017	BE Compl Sem I
1358	2020.21	Deep Ashvinkumar Paun	18111011BE35		BE Compl Sem I



1359	2020.21	Vinita Ravindra Sangle	SOE1704084	25/07/2017	BE Compl Sem I
1360	2020.21	Pranav Subhash Lonari	SOE1805152	14/08/2018	BE Compl Sem I
1361	2020.21	Divya Vipin Sathe	SOE1704641	28/08/2017	BE Compl Sem I
1362	2020.21	Shreyas Ravindra Lokhande	SOE1805149		BE Compl Sem I
1363	2020.21	Shubham Keshari Sharma	SOE1704036	25/07/2017	BE Compl Sem I
1364	2020.21	Narendra Sadanand Choudhary	SOE1805242	2018-2019	BE Compl Sem I
1365	2020.21	Omkar Krishna Shelke	SOE1704195	27/07/2017	BE Compl Sem I
1366	2020.21	Swati Ram Jagtap	SOE1805155	13/08/2018	BE Compl Sem I
1367	2020.21	Mohini Keru Raykar	SOE1704257	28/07/2017	BE Compl Sem I
1368	2020.21	Kunal Rajendra Milkhe	SOE1805216	16/08/2018	BE Compl Sem I
1369	2020.21	Chaitanya Govindrao Suryawanshi	SOE1704051	25/07/2017	BE Compl Sem I
1370	2020.21	Taufik Salim Tamboli	SOE1704081	25/07/2017	BE Compl Sem I
1371	2020.21	Piyush Prashant Takale	SOE1805185		BE Compl Sem I
1372	2020.21	Vishakha Vishwas Tapkir	SOE1704336	05-08-2017	BE Compl Sem I
1373	2020.21	Saurav Ramakant Tayade	SOE1704260	28/07/2017	BE Compl Sem I
1374	2020.21	Shreyas Vinay Tembhekar	SOE1704295	29/07/2017	BE Compl Sem I
1375	2020.21	Chetan Dilip Gadekar	SOE1603521	05-08-2016	BE Compl Sem I
1376	2020.21	Pragati Chandrakant Mote	1801101 BE22	30/08/2018	BE Compl Sem I
1377	2020.21	Akshada Vishwas Tingare	SOE1704334	05-08-2017	BE Compl Sem I
1378	2020.21	Aniket Kundanlal Chaudhary	SOE1805332	18/08/2018	BE Compl Sem I
1379	2020.21	Aishwarya Avinash Tingre	SOE1704339	27/11/2017	BE Compl Sem I
1380	2020.21	Sanjivani Anand Durgale	SOE1805264		BE Compl Sem I
1381	2020.21	Jayesh Ashish Trivedi	SOE1704325	04-08-2017	BE Compl Sem I
1382	2020.21	Karunesh Singh Bais	SOE1603125	20/07/2016	BE Compl Sem I
1383	2020.21	Michelle Pragatbhai Trivedi	SOE1704648	29/08/2017	BE Compl Sem I
1384	2020.21	Rutuja Mohan Vetal	SOE1603504	05-08-2016	BE Compl Sem I
1385	2020.21	Neha Vinayak Kamble	SOE1502498	2019-2020	BE Compl Sem I
1386	2020.21	Shubham Shankar Bhosale	SOE1704311	29/07/2017	BE Compl Sem I
1387	2020.21	Shubham Satish Yerunkar	SOE1704220	28/07/2017	BE Compl Sem I
1388	2020.21	Prachi Vishwanath Andhare	SOE1603219	30/07/2016	BE Compl Sem I
1389	2020.21	Pragati Uttam Shitole	SOE1704189	27/07/2017	BE Compl Sem I
1390	2020.21	Srushti Sunil Anap	SOE1603486	05-08-2016	BE Compl Sem I
1391	2020.21	Reshma Santosh Burde	SOE1603482	2019-2020	BE Compl Sem I
1392	2020.21	Rohit Babu Hodage	SOE1603934		BE Compl Sem I
1393	2020.21	Prashant Balasaheb Yeole	SOE1704104	26/07/2017	BE Compl Sem I
1394	2020.21	Tushar Chandrakant Gangurde	SOE1704219	28/07/2017	BE Compl Sem I
1395	2020.21	Manorama Sandeep Shewale	SOE1704666	13/09/2017	BE Compl Sem I
1396	2020.21	Kartik Sanjay Kaushik	SOE1502420		BE Compl Sem I
1397	2020.21	Priyanka Sunil Pathare	SOE1704331	05-08-2017	BE Compl Sem I
1398	2020.21	Tejashri Anil Sawant	SOE1704579	19/08/2017	BE Compl Sem I
1399	2020.21	Shubham Dilip Ware	SOE1604010		BE Compl Sem I
1400	2020.21	Nihal Santosh Chhetri	SOE1704613	28/08/2017	BE Compl Sem I
1401	2020.21	Akash Raju Mote	SOE1704445	16/08/2017	BE Compl Sem I
1402	2020.21	Prince Kumar Singh	SOE1502757	09-07-2015	BE Compl Sem I
1403	2020.21	Shivsharan Pritam Patil	SOE1603682		BE Compl Sem I
1404	2020.21	Mayuresh Yogesh Kulkarni	SOE1603107	2019-2020	BE Compl Sem I
1405	2020.21	Ankita Dattatray Salunke	SOE1704503	2019-2020	BE Compl Sem I



1406	2020.21	Prashant Gajanan Chaudhari	SOE1704537	18/08/2017	BE Comp1 Sem I
1407	2020.21	Shital Vishwakarma Janjal	SOE1603499	05-08-2016	BE Comp1 Sem I
1408	2020.21	Vrushali Vilas Borle	SOE1704121	26/07/2017	BE Comp1 Sem I
1409	2020.21	Tushar Anand Jha	SOE1502822	04-08-2015	BE Comp1 Sem I
1410	2020.21	Manali Pradeep Kamble	SOE1603246	01-08-2016	BE Comp1 Sem I
1411	2020.21	Saurabh Shankar Ovhal	SOE1603279	01-08-2016	BE Comp1 Sem I
1412	2020.21	Ronak Thusoo	19111011BE42		BE Comp1 Sem I
1413	2020.21	Ritin Ranjan Dixit	SOE1503009	12-08-2015	BE Comp1 Sem I
1414	2020.21	Rohan Ranjit Patil	SOE1603500	05-08-2016	BE Comp1 Sem I
1415	2020.21	Sanika Ramdas Aier	SOE1603433	04-08-2016	BE Comp1 Sem I
1416	2020.21	Kanhaiya Jagannath Patil	SOE1502502		BE Comp1 Sem I
1417	2020.21	Rutuja Kiran Jade	SOE1502595	06-07-2015	BE Comp1 Sem I
1418	2020.21	Apekshita Subhash Bhosale	SOE1502620	12-07-2015	BE Comp1 Sem I
1419	2020.21	Kshitija Babanrao Gade	19031011BE43		BE Comp1 Sem I
1420	2020.21	Bhagyashree Prakash Ramteke	SOE1502482	02-07-2015	BE Comp1 Sem I
1421	2020.21	Vaibhav Bandu Manwar	SOE1603369	03-08-2016	BE Comp1 Sem I
1422	2020.21	Mayur Sopan Doke	SOE1603501	05-08-2016	BE Comp1 Sem I
1423	2020.21	Venkati Hiranman Mane	SOE1603391	2019-2020	BE Comp1 Sem I
1424	2020.21	Pooja Jagdish Sharma	19111011BE171	14/08/2019	BE Comp1 Sem I
1425	2020.21	Omkar Balajirao Ambegave	SOE1502959		BE Comp1 Sem I
1426	2020.21	Manish Ramakant Pandey	12011011BE664	03-03-2021	BE Mech1 Sem I
1427	2020.21	Akshay Ashok Hedau	20011011BE608	02-03-2021	BE Mech1 Sem I
1428	2020.21	Pankaj Ishwar Chaudhari	SOE1704406	16/08/2017	BE Mech1 Sem I
1429	2020.21	Aditya Rajeshkumar Verma	SOE1704210	27/07/2017	BE Mech1 Sem I
1430	2020.21	Tejas Sunil Agashe	SOE1805315		BE Mech1 Sem I
1431	2020.21	Kaustubh Suresh Ambhorkar	SOE1805284		BE Mech1 Sem I
1432	2020.21	Prashant Bhausaheb Amrao	SOE1805319		BE Mech1 Sem I
1433	2020.21	Amrit Raj	SOE1704053		BE Mech1 Sem I
1434	2020.21	Vaibhav Baban Andhale	SOE1805189	2018-2019	BE Mech1 Sem I
1435	2020.21	Tejas Gajabhau Bangar	SOE1805207		BE Mech1 Sem I
1436	2020.21	Akshay Pradeep Bankar	SOE1805102		BE Mech1 Sem I
1437	2020.21	Aniket Subhashrao Bardhe	SOE1805236	2018-2019	BE Mech1 Sem I
1438	2020.21	Piyush Hemant Bari	SOE1805177	2018-2019	BE Mech1 Sem I
1439	2020.21	Bhalchandra D Shirke	SOE1805124		BE Mech1 Sem I
1440	2020.21	Suraj Sanjay Bhanuse	SOE1805135	2018-2019	BE Mech1 Sem I
1441	2020.21	Harshal Yashwant Bharti	SOE1805282		BE Mech1 Sem I
1442	2020.21	Omkar Raju Bhise	SOE1805211		BE Mech1 Sem I
1443	2020.21	Subhash Krushna Bongane	SOE1704126	26/07/2017	BE Mech1 Sem I
1444	2020.21	Nitin Uttam Borde	SOE1805326		BE Mech1 Sem I
1445	2020.21	Sourabh Shivaji Chakure	SOE1704183	27/07/2017	BE Mech1 Sem I
1446	2020.21	Mahesh Ajit Chaudhari	SOE1704123	26/07/2017	BE Mech1 Sem I
1447	2020.21	Omkar Ramakant Chavan	18011021BE7	2018-2019	BE Mech1 Sem I
1448	2020.21	Saurabh Laxman Dagade	SOE1805131		BE Mech1 Sem I
1449	2020.21	Akshay Lakshmanrao Dakh	SOE1805221		BE Mech1 Sem I
1450	2020.21	Pranjal Gopalrao Dasarwar	SOE1704198	15/09/2017	BE Mech1 Sem I
1451	2020.21	Sourabh Anand Daund	SOE1704199	27/07/2017	BE Mech1 Sem I
1452	2020.21	Rohan Sanjay Desai	SOE1805181		BE Mech1 Sem I





1453	2020.21	Sainath Kashinath Dhanshetti	SOE1704200	2018-2019	BE MechI Sem I
1454	2020.21	Abhijeet Machhindranath Dhaygude	SOE1805072		BE MechI Sem I
1455	2020.21	Hrishikesh Dattatray Dusane	SOE1805078		BE MechI Sem I
1456	2020.21	Prakash Bhagwan Funde	SOE1603233	31/07/2016	BE MechI Sem I
1457	2020.21	Shubham Bhaskar Funde	SOE1805128		BE MechI Sem I
1458	2020.21	Shailesh Prashant Gade	SOE1805106		BE MechI Sem I
1459	2020.21	Aaditya Madhukar Gaikwad	SOE1805140		BE MechI Sem I
1460	2020.21	Niteshkumar Rajendra Gaikwad	SOE1805295		BE MechI Sem I
1461	2020.21	Rohit Umesh Gaikwad	SOE1805026		BE MechI Sem I
1462	2020.21	Nikhil Prashant Garse	SOE1805280		BE MechI Sem I
1463	2020.21	Akshay Samadhan Gavhane	SOE1603549	06-08-2016	BE MechI Sem I
1464	2020.21	Aniketh Babasaheb Gawade	SOE1603293	2018-2019	BE MechI Sem I
1465	2020.21	Mahadev Shashikant Gawali	SOE1805116		BE MechI Sem I
1466	2020.21	Himanshu Prashant Gawande	SOE1704359	06-08-2017	BE MechI Sem I
1467	2020.21	Parag Sanjay Ghanokar	SOE1805246		BE MechI Sem I
1468	2020.21	Gaurav Rajendra Ghube	SOE1805214		BE MechI Sem I
1469	2020.21	Saurabh Sopan Ghuge	SOE1805121		BE MechI Sem I
1470	2020.21	Amol Dagaji Hyalij	SOE1805090		BE MechI Sem I
1471	2020.21	Abhishek Kashinath Jadhav	SOE1704146	26/07/2017	BE MechI Sem I
1472	2020.21	Balram Kumar Jha	SOE1502727	06-07-2015	BE MechI Sem I
1473	2020.21	Tejas Vikas Shinde	SOE1603494	2019-2020	BE MechI Sem I
1474	2020.21	Dhiraj Anil Sonawane	SOE1603361	02-08-2016	BE MechI Sem I
1475	2020.21	Jayesh Sandip Sonawane	SOE1603249	01-08-2016	BE MechI Sem I
1476	2020.21	Sumit Jwalasingh Bhadoriya	SOE1502605	07-03-2016	BE MechI Sem I
1477	2020.21	Tanmay Vilasrao Ughade	SOE1502631	13/07/2015	BE MechI Sem I
1478	2020.21	Saurabh Dilip Chinchole	SOE1704568	19/08/2017	BE MechI Sem I
1479	2020.21	Sagar Vijay Bhavsar	SOE1502617	12-07-2015	BE MechI Sem I
1480	2020.21	Manohar Dilip Mahale	SOE1502466	02-07-2015	BE MechI Sem I
1481	2020.21	Harsh Kamlesh Bulani	SOE1603435	04-08-2016	BE MechI Sem I
1482	2020.21	Shubham Arun Jadhav	SOE1704201	2018-2019	BE MechI Sem I
1483	2020.21	Prashik Sudhir Ingle	19031021BE15		BE MechI Sem I
1484	2020.21	Shubham Sudhir Palkar	SOE1202388	24/09/2014	BE MechI Sem I
1485	2020.21	Mahesh Dnyandev Gaikwad	SOE1300679	02-08-2013	BE MechI Sem I
1486	2020.21	Shubham Prakash Shedge	SOE1300591	02-08-2013	BE MechI Sem I
1487	2020.21	Vaibhav Sudhir Barure	SOE1301365	05-08-2013	BE MechI Sem I
1488	2020.21	Ashish Dinesh Walzade	SOE1301428	03-12-2013	BE MechI Sem I
1489	2020.21	Omkar Rajaram Surve	20011011BE201	20/08/2020	BE MechI Sem I
1490	2020.21	Sanket Ambadas Ghule	SOE1401773	26/07/2014	BE MechI Sem I
1491	2020.21	Kishor Vitthal Panchal	SOE1401809	27/07/2014	BE MechI Sem I
1492	2020.21	Avinash Panditrao Yadav	SOE1401646	13/08/2018	BE MechI Sem I
1493	2020.21	Manish Kumar Chaudhri	SOE1503060	31/08/2015	BE MechI Sem I
1494	2020.21	Jatin Jagdish Yadav	SOE1704679	14/09/2017	BE MechI Sem I
1495	2020.21	Shubham Shivaji More	SOE1603679	31/08/2016	BE MechI Sem I
1496	2020.21	Kaushal Arvind Jujgar	SOE1704107	26/07/2017	BE MechI Sem I
1497	2020.21	Pradnyesh Bhagwan Kadam	SOE1704067	25/07/2017	BE MechI Sem I
1498	2020.21	Prashant Ashokrao Kadam	SOE1704226	28/07/2017	BE MechI Sem I
1499	2020.21	Suyash Sudhir Kadam	SOE1704115	26/07/2017	BE MechI Sem I



1500	2020.21	Pravin Satwik Kalburgi	SOE1805075		BE MechI Sem I
1501	2020.21	Shivam Baburao Kale	SOE1805035		BE MechI Sem I
1502	2020.21	Shreyash Popat Kamble	SOE1704161	27/07/2017	BE MechI Sem I
1503	2020.21	Vishal Yuvraj Kamble	SOE1805052		BE MechI Sem I
1504	2020.21	Karthik Chary Sajjana	SOE1704350	06-08-2017	BE MechI Sem I
1505	2020.21	Kaustubh Kashinath Dhawale	SOE1704358	06-08-2017	BE MechI Sem I
1506	2020.21	Shreyash Arun Kausal	SOE1805076	2018-2019	BE MechI Sem I
1507	2020.21	Kaustubh Narendra Keskar	SOE1704171	2018-2019	BE MechI Sem I
1508	2020.21	Ranjit Ramchandra Koli	18081021BE5	2018-2019	BE MechI Sem I
1509	2020.21	Rohit Ramchandra Koli	SOE1805161	2018-2019	BE MechI Sem I
1510	2020.21	Mangesh Dilip Kondke	SOE1805314	2018-2019	BE MechI Sem I
1511	2020.21	Amitkumar Balasaheb Kshirsagar	SOE1805197		BE MechI Sem I
1512	2020.21	Ashwini Ashokrao Kurekar	SOE1805077		BE MechI Sem I
1513	2020.21	Ashok Shivaji Kute	SOE1704305	29/07/2017	BE MechI Sem I
1514	2020.21	Hanumant Narayan Lakudzode	SOE1704063	25/07/2017	BE MechI Sem I
1515	2020.21	Sumit Dattatray Lokhande	SOE1805101		BE MechI Sem I
1516	2020.21	Jayesh Yogendra Mahajan	SOE1805206		BE MechI Sem I
1517	2020.21	Mahendra Vitthal Deore	SOE1805089		BE MechI Sem I
1518	2020.21	Gaurav Subhash Malode	SOE1603136	20/07/2016	BE MechI Sem I
1519	2020.21	Abhishek Dinkar Mandavkar	SOE1805205	2018-2019	BE MechI Sem I
1520	2020.21	Bhupesh Ramchandra Mhatre	18011021BE1	2018-2019	BE MechI Sem I
1521	2020.21	Mohnish Gautam Baviskar	SOE1805247	2018-2019	BE MechI Sem I
1522	2020.21	Arsalan Intiyaz Momin	SOE1805080		BE MechI Sem I
1523	2020.21	Prathamesh Makardhwaj Mule	SOE1805163	2018-2019	BE MechI Sem I
1524	2020.21	Sourav Ramchandra Nanaware	SOE1805301		BE MechI Sem I
1525	2020.21	Prashant Shyam Narke	SOE1704215	27/07/2017	BE MechI Sem I
1526	2020.21	Akash Sanjeev Navgire	18011021BE11	2018-2019	BE MechI Sem I
1527	2020.21	Pravin Shantaram Nichit	SOE1704090	26/07/2017	BE MechI Sem I
1528	2020.21	Nishant Ashok Pandey	SOE1704262	28/07/2017	BE MechI Sem I
1529	2020.21	Jay Pandharinath Pagar	SOE1603422	03-08-2016	BE MechI Sem I
1530	2020.21	Bhaveshe Lakshandev Pal	SOE1805320	2018-2019	BE MechI Sem I
1531	2020.21	Akshay Bhanudas Patil	SOE1805037		BE MechI Sem I
1532	2020.21	Kalmesh Mohan Patil	SOE1704106	26/07/2017	BE MechI Sem I
1533	2020.21	Manoj Jalindar Patil	SOE1805244		BE MechI Sem I
1534	2020.21	Pratik Mohan Patil	SOE1805034		BE MechI Sem I
1535	2020.21	Vinayak Shankar Patil	SOE1805230		BE MechI Sem I
1536	2020.21	Amar Avinash Patil	SOE1805017		BE MechI Sem I
1537	2020.21	Ganesh Bajirao Patole	SOE1502670	14/07/2015	BE MechI Sem I
1538	2020.21	Shailendra Mahendra Pratap Singh	SOE1603380	03-08-2016	BE MechI Sem I
1539	2020.21	Prasad Rajendrakumar Thorat	SOE1704510	18/08/2017	BE MechI Sem I
1540	2020.21	Swapnil Raju More	SOE1704408	2019-2020	BE MechI Sem I
1541	2020.21	Satyam Dnyaneshwar Gopale	SOE1603239	01-08-2016	BE MechI Sem I
1542	2020.21	Ganesh Pramod Huse	SOE1502612	12-07-2015	BE MechI Sem I
1543	2020.21	Somnath Satyawan Badde	SOE1502626	12-07-2015	BE MechI Sem I
1544	2020.21	Jayesh Ramesh Komalwar	SOE1603182	06-01-2017	BE MechI Sem I
1545	2020.21	Shantanu Harish Gaikwad	SOE1704487	17/08/2017	BE MechI Sem I
1546	2020.21	Shubham Chandrikant Pawar	SOE1503028	2019-2020	BE MechI Sem I



1547	2020.21	Aditya Arvind Khete	SOE1502422	23/06/2015	BE MechI Sem I
1548	2020.21	Mangesh Bajirao Pawase	SOE1502564	2019-2020	BE MechI Sem I
1549	2020.21	Vijaykumar Eknath Khandvi	19041021BE51	2019-2020	BE MechI Sem I
1550	2020.21	Rohit Vilas Londhe	SOE1704233	28/07/2017	BE MechI Sem I
1551	2020.21	Prince Divakar Mishra	SOE1704356	06-08-2017	BE MechI Sem I
1552	2020.21	Shriram Gorakh Kachole	SOE1502696	14/07/2015	BE MechI Sem I
1553	2020.21	Shubham Rajendra Bansod	SOE1502651	13/07/2015	BE MechI Sem I
1554	2020.21	Uday Dattatray Kokane	SOE1502658	13/07/2015	BE MechI Sem I
1555	2020.21	Vivek - -	SOE1502742	17/07/2015	BE MechI Sem I
1556	2020.21	Rohan Sunil Chavan	SOE1502904	10-08-2015	BE MechI Sem I
1557	2020.21	Gaurav Deepak Gaikwad	SOE1502878	10-08-2015	BE MechI Sem I
1558	2020.21	Akash Subhash Khandare	SOE1502943	10-08-2015	BE MechI Sem I
1559	2020.21	Sohil Rajendra Lahane	SOE1502844	08-08-2015	BE MechI Sem I
1560	2020.21	Shriram Vishwanath Nanaware	SOE1502908	10-08-2015	BE MechI Sem I
1561	2020.21	Amit Gajanan Wankhade	SOE1502850	09-08-2015	BE MechI Sem I
1562	2020.21	Swapnil Santosh Kamble	SOE1603462	04-08-2016	BE MechI Sem I
1563	2020.21	Rushabh Suresh Devkar	SOE1603781	01-09-2016	BE MechI Sem I
1564	2020.21	Shubham Raosaheb Gaikar	SOE1603886	02-09-2016	BE MechI Sem I
1565	2020.21	Omkar Rajesh Hublikar	SOE1603632	31/08/2016	BE MechI Sem I
1566	2020.21	Shantanu Chandrakant Santikar	SOE1603469	04-08-2016	BE MechI Sem I
1567	2020.21	Krishna Dinesh Pawar	SOE1704182	27/07/2017	BE MechI Sem I
1568	2020.21	Rishikesh Vikramsing Pawar	SOE1805093	2018-2019	BE MechI Sem I
1569	2020.21	Tanaji Hanumant Pawar	18011021BE2	2018-2019	BE MechI Sem I
1570	2020.21	Vikrant Vijay Phalke	SOE1805120		BE MechI Sem I
1571	2020.21	Shubham Tukaram Phulsundar	SOE1805204		BE MechI Sem I
1572	2020.21	Aniket Sunil Pote	SOE1704039	25/07/2017	BE MechI Sem I
1573	2020.21	Samadhan Vinayak Ranmale	SOE1805278	2018-2019	BE MechI Sem I
1574	2020.21	Shiv Vilas Raut	SOE1704290	29/07/2017	BE MechI Sem I
1575	2020.21	Arpit Sudhakar Sahare	SOE1805147		BE MechI Sem I
1576	2020.21	Siddharth Dnyaneshwar Salunke	SOE1704277	28/07/2017	BE MechI Sem I
1577	2020.21	Pratik Ramchandra Salunkhe	SOE1805305		BE MechI Sem I
1578	2020.21	Subhash Sanjay Salunkhe	SOE1704118	26/07/2017	BE MechI Sem I
1579	2020.21	Sangave Maharudra Hanumant	SOE1805066		BE MechI Sem I
1580	2020.21	Tanay Sanjeev Sankhe	SOE1805202		BE MechI Sem I
1581	2020.21	Saurabh Kisan Sapkal	SOE1805020		BE MechI Sem I
1582	2020.21	Akshaykumar Sahebrao Sarje	SOE1805254		BE MechI Sem I
1583	2020.21	Shreyas Anil Sarode	SOE1805145		BE MechI Sem I
1584	2020.21	Shubham Sambhaji Saste	SOE1704318	2018-2019	BE MechI Sem I
1585	2020.21	Omkar Raju Sattarshetty	SOE1603481	05-08-2016	BE MechI Sem I
1586	2020.21	Saurabh Manik Raundal	SOE1805091		BE MechI Sem I
1587	2020.21	Arsalan Gulrez Sayed	SOE1805323		BE MechI Sem I
1588	2020.21	Maroof Shahanur Shaikh	SOE1805126	2018-2019	BE MechI Sem I
1589	2020.21	Arbaj Saheblal Shikalgar	SOE1704258	28/07/2017	BE MechI Sem I
1590	2020.21	Sumit Dattatray Shinde	SOE1805210		BE MechI Sem I
1591	2020.21	Ritesh Ravindra Shirke	SOE1805132		BE MechI Sem I
1592	2020.21	Shubham Dharmaraj Alhat	SOE1704059	25/07/2017	BE MechI Sem I
1593	2020.21	Simarpreet Singh Wahi	SOE1603227	31/07/2016	BE MechI Sem I



1594	2020.21	Kundan Ramadhar Singh	SOE1805331		BE MechI Sem I
1595	2020.21	Rahul Kondiba Sonawane	SOE1805229		BE MechI Sem I
1596	2020.21	Sourabh Sudhakar Mamidwar	SOE1704296	29/07/2017	BE MechI Sem I
1597	2020.21	Amit Ramakant Suryawanshi	SOE1805054		BE MechI Sem I
1598	2020.21	Rihan Harun Tamboli	SOE1704321	2018-2019	BE MechI Sem I
1599	2020.21	Rahul Sandip Tawade	SOE1704285	29/07/2017	BE MechI Sem I
1600	2020.21	Shweta Rajesh Thakur	SOE1805272		BE MechI Sem I
1601	2020.21	Sarvesh Ulhasrao Thigale	SOE1805073		BE MechI Sem I
1602	2020.21	Saurabh Yeshwant Thorat	SOE1704224	28/07/2017	BE MechI Sem I
1603	2020.21	Harshkumar Rakeshkumar Tiwari	SOE1704628	28/08/2017	BE MechI Sem I
1604	2020.21	Rishikesh Sunil Ukirde	SOE1603431	03-08-2016	BE MechI Sem I
1605	2020.21	Vikas Sampat Lagad	SOE1805330	2018-2019	BE MechI Sem I
1606	2020.21	Jayesh Hemant Wadke	SOE1805156	2018-2019	BE MechI Sem I
1607	2020.21	Swapnil Yashwant Waghule	SOE1805199		BE MechI Sem I
1608	2020.21	Sanket Machhindra Walse	SOE1805154		BE MechI Sem I
1609	2020.21	Yojita Kirtiraj Rajput	SOE1603563	08-08-2016	BE MechI Sem I
1610	2020.21	Akshay Ratilal Zanzane	SOE1805053	2018-2019	BE MechI Sem I
1611	2020.21	Parmeshwar Ram Zirmire	SOE1805117		BE MechI Sem I
1612	2020.21	Kalyani Ramesh Deshmukh	SOE1704386	16/08/2017	BE MechI Sem I
1613	2020.21	Abhishek Rajendra Shinde	SOE1603152	21/07/2016	BE MechI Sem I
1614	2020.21	Sanketh Ganesh Pawar	SOE1502572	04-07-2015	BE MechI Sem I
1615	2020.21	Omkar Vilas Joshi	19011021BE12		BE MechI Sem I
1616	2020.21	Manmohan Dhananjay Nath	SOE1603157	21/07/2016	BE MechI Sem I
1617	2020.21	Ajay Arvind Panchal	SOE1603139	20/07/2016	BE MechI Sem I
1618	2020.21	Raj Mohan Kachare	19021021BE13		BE MechI Sem I
1619	2020.21	Shashankdev Satyadev Berailly	SOE1603471	04-08-2016	BE MechI Sem I
1620	2020.21	Nishit Kumar Devanarayanlal Das	19011021BE27		BE MechI Sem I
1621	2020.21	Shashikant Umaji Mane	SOE1704507	17/08/2017	BE MechI Sem I
1622	2020.21	Sushant Ramesh Gaikwad	SOE1704496	17/08/2017	BE MechI Sem I
1623	2020.21	Kunal Yogesh Raut	SOE1805022	2018-2019	BE MechI Sem I
1624	2020.21	Venkatesh Muthu Pillai	SOE1704288	29/07/2017	BE MechI Sem I
1625	2020.21	Saurabh Bhagawat Zingade	SOE1805219		BE MechI Sem I
1626	2020.21	Tejas Chandrashekhar Mondhe	SOE1604025	28/09/2016	BE MechI Sem I
1627	2020.21	Aniket Jagannath Nimbalkar	SOE1603929	02-09-2016	BE MechI Sem I
1628	2020.21	Aniket Jagannath Nimbalkar	SOE1603825	02-09-2016	BE MechI Sem I
1629	2020.21	Anthony Francis Pinto	SOE1704504	17/08/2017	BE MechI Sem I
1630	2020.21	Rohankumar Madhusudan Devdhar	SOE1704402	16/08/2017	BE MechI Sem I
1631	2020.21	Vishnu Baliram Gawali	SOE1704390	16/08/2017	BE MechI Sem I
1632	2020.21	Nana Ramdas Kamble	SOE1704677	14/09/2017	BE MechI Sem I
1633	2020.21	Sachin Rajender Chandel	SOE1704414	16/08/2017	BE MechI Sem I
1634	2020.21	Ulka Bhalchandra Saste	SOE1704395	16/08/2017	BE MechI Sem I
1635	2020.21	Shreya Anilrao Kawale	SOE1704543	18/08/2017	BE MechI Sem I
1636	2020.21	Vighneshwar Gangadhar Manchikatla	SOE1502677	08-03-2017	BE MechI Sem I
1637	2020.21	Sharad Atmaram Ingle	SOE1704301		BE Civil Sem I
1638	2020.21	Anand Yadavrao Yadav	SOE1704184	27/07/2017	BE Civil Sem I
1639	2020.21	Apurva Shailesh Bhagat	SOE1401728		BE Civil Sem I
1640	2020.21	Pravin Kishanrao Gaikwad	SOE1401672	2014	BE Civil Sem I
1640	2020.21	Yogesh Sudam Misal			



1641	2020.21	Abhishek Bharat Sapkal	19021041BE3		BE Civil Sem I
1642	2020.21	Ann John Ronel	SOE1502768		BE Civil Sem I
1643	2020.21	Akash Ashok Tope	SOE1502492	02-07-2015	BE Civil Sem I
1644	2020.21	Vivek Girish Kacha	SOE1502419		BE Civil Sem I
1645	2020.21	Atish Mansing Tondale	SOE1603165	21/07/2016	BE Civil Sem I
1646	2020.21	Abhishek Bhausahab Kate	SOE1502607	11-07-2015	BE Civil Sem I
1647	2020.21	Jash Kamlesh Chauhan	SOE1603164	21/07/2016	BE Civil Sem I
1648	2020.21	Shubham Surendra Bhutkar	SOE1603534	27/08/2016	BE Civil Sem I
1649	2020.21	Sameer Muktar Inamdar	SOE1603558		BE Civil Sem I
1650	2020.21	T Ajajit	11011011BE666	24/03/2021	BE Civil Sem I
1651	2020.21	Pruthviraj Bhagwat Jadhav	SOE1603277	01-08-2016	BE Civil Sem I
1652	2020.21	Manish Jayprakash Kumar	SOE1603588	13/08/2016	BE Civil Sem I
1653	2020.21	Nitin Shivaji Najan	SOE1603304	25/08/2016	BE Civil Sem I
1654	2020.21	Tejas Kamalakar Nandre	SOE1603290	01-08-2016	BE Civil Sem I
1655	2020.21	Vishal Vishnu Kolage	SOE1603411	03-08-2016	BE Civil Sem I
1656	2020.21	Vikas Sukhdev Bankar	SOE1704079	25/07/2017	BE Civil Sem I
1657	2020.21	Ashish Ashok Ranjan	SOE1401746		BE Civil Sem I
1658	2020.21	Divya Subash Khanal	SOE1704616	28/08/2017	BE Civil Sem I
1659	2020.21	Manthan Ganeshrao Kalpande	SOE1704050	25/07/2017	BE Civil Sem I
1660	2020.21	Deepak Nandkumar Patil	20011011BE210	28/12/2020	BE Civil Sem I
1661	2020.21	Swapnil Bhanudas Kapare	SOE1704272	28/07/2017	BE Civil Sem I
1662	2020.21	Ajay Shahaji Madake	SOE1704112	26/07/2017	BE Civil Sem I
1663	2020.21	Akash Vishvambhar Maske	SOE1704145	26/07/2017	BE Civil Sem I
1664	2020.21	Praveen Gopal Pawar	SOE1704306	29/07/2017	BE Civil Sem I
1665	2020.21	Bhupendra Santosh Rakhunde	SOE1704347	05-08-2017	BE Civil Sem I
1666	2020.21	Rohan Subhash Kumawat	SOE1704680	11-10-2017	BE Civil Sem I
1667	2020.21	Ansar Khaleel Shaik	SOE1704085	25/07/2017	BE Civil Sem I
1668	2020.21	Samiksha Dinesh Shirke	SOE1704348	05-08-2017	BE Civil Sem I
1669	2020.21	Shubham Sujit Bhutada	SOE1704624	12-09-2017	BE Civil Sem I
1670	2020.21	Shambhuraje Suresh Vaidya	SOE1704319	29/07/2017	BE Civil Sem I
1671	2020.21	Darpan Hemantkumar Dalvi	SOE1704228	28/07/2017	BE Civil Sem I
1672	2020.21	Yashshree Shailendra Patil	SOE1704345	05-08-2017	BE Civil Sem I
1673	2020.21	Ayush Rajkumar Agarwal	SOE1805273		BE Civil Sem I
1674	2020.21	Gayatri Kailas Ahirrao	SOE1805148		BE Civil Sem I
1675	2020.21	Asif Rafik Shaikh	SOE1805283		BE Civil Sem I
1676	2020.21	Prajakta Nagnath Barangule	SOE1805021		BE Civil Sem I
1677	2020.21	Rushikesh Dhanraj Bhalerao	SOE1805201		BE Civil Sem I
1678	2020.21	Sandip Dhananjay Bhorkar	SOE1805113		BE Civil Sem I
1679	2020.21	Aditi Ashok Davang	SOE1805270	2018-2019	BE Civil Sem I
1680	2020.21	Dipali Pandurang Ambipure	SOE1805312		BE Civil Sem I
1681	2020.21	Ganesh Suresh Makashe	SOE1805110		BE Civil Sem I
1682	2020.21	Pravin Balu Gavit	SOE1805258	2018-2019	BE Civil Sem I
1683	2020.21	Kshitija Vijay Kawade	SOE1805194		BE Civil Sem I
1684	2020.21	Shivani Sunil Kusalkar	SOE1805046		BE Civil Sem I
1685	2020.21	Parth Nagesh Banpatte	SOE1704506	17/08/2017	BE Civil Sem I
1686	2020.21	Maqsd Ahemad Magdum Ahemad	SOE1805286		BE Civil Sem I
1687	2020.21	Savita Kamaji Najan	SOE1805259		BE Civil Sem I



1688	2020.21	Akhilesh Vilas Parate	SOE1805213		BE CivilI Sem I
1689	2020.21	Nikita Dnyaneshwar Patil	SOE1805057		BE CivilI Sem I
1690	2020.21	Rohan Nitin Patil	SOE1805107		BE CivilI Sem I
1691	2020.21	Shivani Atmaram Rangwal	SOE1805220		BE CivilI Sem I
1692	2020.21	Ashvini Vikas Rathod	SOE1805261		BE CivilI Sem I
1693	2020.21	Akashay Bandu Suryawanshi	SOE1805111	2018-2019	BE CivilI Sem I
1694	2020.21	Abhishek Tilekar	18011041BE1		BE CivilI Sem I
1695	2020.21	Vaibhav Anant Shingare	SOE1805024		BE CivilI Sem I
1696	2020.21	Shekhar Ravindra Vanjari	SOE1805129		BE CivilI Sem I
1697	2020.21	Akshay Balasaheb Abuj	SOE1603551		BE CivilI Sem I
1698	2020.21	Vinaya Santosh Rasal	SOE1300180	02-08-2013	BE ENTC1 Sem I
1699	2020.21	Dakshayani Someshwar Swami	SOE1502652	13/07/2015	BE ENTC1 Sem I
1700	2020.21	Saloni Rajendra Aitlawar	SOE1704292	29/07/2017	BE ENTC1 Sem I
1701	2020.21	Ajay Singh	18111031BE3	2018-2019	BE ENTC1 Sem I
1702	2020.21	Akash Yashwantrao Chavan	SOE1704125	26/07/2017	BE ENTC1 Sem I
1703	2020.21	Neha Sudhakar Ambuskar	SOE1704484	17/08/2017	BE ENTC1 Sem I
1704	2020.21	Javed Rajiullah Ansari	SOE1502549	03-07-2015	BE ENTC1 Sem I
1705	2020.21	Prateek Prashant Awate	SOE1603488		BE ENTC1 Sem I
1706	2020.21	Prathamesh Charudatta Badgujar	SOE1603306	26/09/2016	BE ENTC1 Sem I
1707	2020.21	Balveen Sing Sahota	SOE1704600	28/08/2017	BE ENTC1 Sem I
1708	2020.21	Rushikesh Ashok Bamdale	SOE1704191	2019-2020	BE ENTC1 Sem I
1709	2020.21	Sukanya Dharmendra Bansode	SOE1704221	28/07/2017	BE ENTC1 Sem I
1710	2020.21	Somesh Ulhas Bedarkar	SOE1704492	17/08/2017	BE ENTC1 Sem I
1711	2020.21	Balaji Tulshidas Burshe	SOE1603616		BE ENTC1 Sem I
1712	2020.21	Nikhil Shivaji Chaudhari	SOE1704259	28/07/2017	BE ENTC1 Sem I
1713	2020.21	Priyanka Sanjay Chourasia	SOE1704242	28/07/2017	BE ENTC1 Sem I
1714	2020.21	Ajay Balasaheb Darakhe	SOE1805027		BE ENTC1 Sem I
1715	2020.21	Suchismita Subhasis Das	SOE1502571		BE ENTC1 Sem I
1716	2020.21	Deepak Kumar	SOE1704685	11-10-2017	BE ENTC1 Sem I
1717	2020.21	Akash Rajesh Devpandey	SOE1704375	06-08-2017	BE ENTC1 Sem I
1718	2020.21	Prachi Ravindra Dhone	SOE1704469	17/08/2017	BE ENTC1 Sem I
1719	2020.21	Rushikesh Dnyandev Dhule	SOE1502539	19/06/2018	BE ENTC1 Sem I
1720	2020.21	Swapnil Shankar Garad	SOE1704554	2019-2020	BE ENTC1 Sem I
1721	2020.21	Nitin Yuvraj Ghorpade	SOE1704446	16/08/2017	BE ENTC1 Sem I
1722	2020.21	Sumeet Ravindra Handore	SOE1603649	31/08/2016	BE ENTC1 Sem I
1723	2020.21	Ganesh Babasaheb Harkal	SOE1603357		BE ENTC1 Sem I
1724	2020.21	Sopan Dhanraj Hatwar	SOE1603658	31/08/2016	BE ENTC1 Sem I
1725	2020.21	Ratnaraj Ravindra Jadhav	SOE1502499		BE ENTC1 Sem I
1726	2020.21	Pavan Chandrakant Jagtap	SOE1704158	27/07/2017	BE ENTC1 Sem I
1727	2020.21	Piyush Satish Kadam	SOE1603719		BE ENTC1 Sem I
1728	2020.21	Rohit Sanjay Kadam	SOE1704075	25/07/2017	BE ENTC1 Sem I
1729	2020.21	Akash Annasaheb Kale	SOE1603645	31/08/2016	BE ENTC1 Sem I
1730	2020.21	Danish Badruddin Khan	SOE1704373	06-08-2017	BE ENTC1 Sem I
1731	2020.21	Mukul Kishor Khandalkar	SOE1704127	26/07/2017	BE ENTC1 Sem I
1732	2020.21	Pranav Ajay Kurankar	SOE1704253	28/07/2017	BE ENTC1 Sem I
1733	2020.21	Mohd Hamid -	SOE1603596	12-01-2017	BE ENTC1 Sem I
1734	2020.21	Omkar Gopal More	SOE1704363	06-08-2017	BE ENTC1 Sem I



1735	2020.21	Shubham Subhash More	SOE1704368	06-08-2017	BE ENTC1 Sem I
1736	2020.21	Krishnakant Dhananjay Nivangune	SOE1704111	26/07/2017	BE ENTC1 Sem I
1737	2020.21	Nishad Pradeep Kharote	SOE1704322	29/07/2017	BE ENTC1 Sem I
1738	2020.21	Prabal Pankajkumar Pandey	SOE1704310	29/07/2017	BE ENTC1 Sem I
1739	2020.21	Niraj Satish Rajpathak	SOE1704041	25/07/2017	BE ENTC1 Sem I
1740	2020.21	Vaibhav Tanaji Randhave	SOE1704109	26/07/2017	BE ENTC1 Sem I
1741	2020.21	Ritika Jha	SOE1704073	25/07/2017	BE ENTC1 Sem I
1742	2020.21	Rohini Bhauso Mhaske	SOE1704460	17/08/2017	BE ENTC1 Sem I
1743	2020.21	Sameeksha Kunwar Singh	SOE1604026		BE ENTC1 Sem I
1744	2020.21	Asim Shabbir Shaikh	SOE1603804	02-09-2016	BE ENTC1 Sem I
1745	2020.21	Shridhar Narayan Shelar	SOE1704152	27/07/2017	BE ENTC1 Sem I
1746	2020.21	Shivangi Sushant Agnihotri	SOE1704213	27/07/2017	BE ENTC1 Sem I
1747	2020.21	Swati Bambam Jha	SOE1704374	06-08-2017	BE ENTC1 Sem I
1748	2020.21	Tanmay Sanjay Kadam	SOE1704040	25/07/2017	BE ENTC1 Sem I
1749	2020.21	Pratik Tanaji Tapkir	SOE1704372	06-08-2017	BE ENTC1 Sem I
1750	2020.21	Vishalkumar Bhaguji Thombre	SOE1704385	16/08/2017	BE ENTC1 Sem I
1751	2020.21	Aashutosh Vijaykumar Thosar	SOE1603812	02-09-2016	BE ENTC1 Sem I
1752	2020.21	Venkat Saikumar Sai Kumar Vavilashetty	SOE1704134	26/07/2017	BE ENTC1 Sem I
1753	2020.21	Vaibhav Sharad Waghmare	SOE1603806	02-09-2016	BE ENTC1 Sem I
1754	2020.21	Avinash Baburam Yadav	SOE1704066	25/07/2017	BE ENTC1 Sem I
1755	2020.21	Sujit Harishchandra Kadam	SOE1704553	18/08/2017	BE ENTC1 Sem I
1756	2020.21	Komal Yuvraj Udmale	SOE1603788	01-09-2016	BE ENTC1 Sem I
1757	2020.21	Mayur Sopan Gawali	SOE1301307		BE ENTC1 Sem I
1758	2020.21	Dhiraj Pandurang Kamble	SOE1502870	09-08-2015	BE ENTC1 Sem I
1759	2020.21	Akash Dilip Barge	SOE1603872	02-09-2016	BE ENTC1 Sem I
1760	2020.21	Saylee Ramesh Mandekar	SOE1603193	30-07-2016	BE ENTC1 Sem I
1761	2020.21	Ram Kashinath Dhas	SOE1300750	02-08-2013	BE ENTC1 Sem I
PG					
1762	2020.21	arati Dilip Kamble	20031101ME4	02-08-2021	FY-ME Comp1 Sem I
1763	2020.21	MAYANK BHASKAR	20011101ME9	02-08-2021	FY-ME E&TC Sem I
1764	2020.21	Pavan prakash Chipade	20011101ME6	02-08-2021	FY-ME Mech1 Sem I
1765	2020.21	AKSHAY RAMCHANDRA MANE	20011101ME8	02-08-2021	FY-ME Mech1 Sem I
1766	2020.21	YOGESH LAXMAN BHOI	21051101ME7	02-08-2021	FY-ME Mech1 Sem I
1767	2020.21	DEEPAK P NAIR	21111101ME5	02-08-2021	FY-ME Mech1 Sem I
1768	2020.21	ASHWINI SUHAS GHANWAT	19021101ME1	02-08-2021	SY-ME Comp1 Sem I
1769	2020.21	PRASHANT NAMDEO KAMBLE	19031101ME1	02-08-2021	SY-ME Comp1 Sem I
1770	2020.21	SITANSHU KUMAR	19111101ME3	02-08-2021	SY-ME Comp1 Sem I
1771	2020.21	KAJAL DEEPAK SHENDE	19011071	02-08-2021	SY-ME E&TC1 Sem I
1772	2020.21	PALLAVI AJIT PATIL	19011071ME3	02-08-2021	SY-ME E&TC1 Sem I
1773	2020.21	SHWETA VASANT SABNE	19021071ME5	02-08-2021	SY-ME E&TC1 Sem I
1774	2020.21	ANMOL DNYANESHWAR PATIL	19031071ME2	02-08-2021	SY-ME E&TC1 Sem I
1775	2020.21	STEFFI K GEORGE	19111071ME4	02-08-2021	SY-ME E&TC1 Sem I
1776	2020.21	RAJKUMAR R ZODGE	190101091ME11	02-08-2021	SY-ME Mech1 Sem I
1777	2020.21	KIRAN VILAS NIKAM	19011071ME1	02-08-2021	SY-ME Mech1 Sem I
1778	2020.21	VISHAL VITTHAL AHIRE	19011091ME12	02-08-2021	SY-ME Mech1 Sem I
1779	2020.21	SANKET BHAUSAHEB SHIRKE	19011091ME13	02-08-2021	SY-ME Mech1 Sem I



1780	2020.21	NISHA HANMANT KHAPALE	19011091ME14	02-08-2021	SY-ME MechI Sem I
1781	2020.21	NITIN KISAN CHOUDHARI	19011091ME15	02-08-2021	SY-ME MechI Sem I
1782	2020.21	GAURAV ANIL UPADHYE	19011091ME18	02-08-2021	SY-ME MechI Sem I
1783	2020.21	Omkar Machhindra Lonkar	19011091ME19	02-08-2021	SY-ME MechI Sem I
1784	2020.21	VISHAL BHAT	19011091ME4	02-08-2021	SY-ME MechI Sem I
1785	2020.21	NARESH S	19011091ME5	02-08-2021	SY-ME MechI Sem I
1786	2020.21	SAILESH KUMAR P	19011091ME6	02-08-2021	SY-ME MechI Sem I
1787	2020.21	SARTHAK MAHAVIR BANGALE	19011091ME7	02-08-2021	SY-ME MechI Sem I
1788	2020.21	DINESH NIMBAJI THAKARE	19011091ME8	02-08-2021	SY-ME MechI Sem I
1789	2020.21	Dipali Kailas Tathe	19021091ME16	02-08-2021	SY-ME MechI Sem I
1790	2020.21	ADITYA PARMANAND KHANDARE	19031091ME2	02-08-2021	SY-ME MechI Sem I
1791	2020.21	Haridip Prakash Khomane	19061091ME1	02-08-2021	SY-ME MechI Sem I
1792	2020.21	URVIND RANJITSING GIRASE	19091091ME3	02-08-2021	SY-ME MechI Sem I
1793	2020.21	Satish Uttamrao Muttalwad	19111091ME10	02-08-2021	SY-ME MechI Sem I
1794	2020.21	ABHISARIKA SHRIVASTAVA	19111091ME17	02-08-2021	SY-ME MechI Sem I
1795	2020.21	vikash ruhela	19111091ME9	02-08-2021	SY-ME MechI Sem I

*(Handwritten signature)*



*(Handwritten signature)*

**Principal**  
Dr. D. Y. Patil School of Engineering  
Lohegaon, Pune.





Dr. D. Y. Patil Group of Institutions' Technical Campus  
**Dr. D. Y. PATIL SCHOOL OF ENGINEERING**  
Dr. D. Y. Patil Knowledge City, Charholi Bk., Via. Lohegaon, Pune – 412 105,  
Department of **Electronics and Telecommunication Engineering**

AY. 2020-21

SE E&TC Roll Call List

Sr. No.	Roll No.	Name of Student
1	201	ABHINAY KUMAR
2	202	AFAAN IDRISI
3	203	BANODIYA NEEL MANOJ
4	204	BATTULA NITIN VENKATESH
5	205	BHOODATT PRATIK RAMESH
6	206	BISHT VIJAYSINGH NIDHI
7	207	CHEERALA KONA NAVEEN
8	208	CHIRIVELLA LAKSHMIMANASA SHRINIVAS
9	209	DABHADE TEJAS PANDHARINATH
10	210	DEEPAK KUMAR THAKUR
11	211	DISHA HEGDE
12	212	DUBE NIHARIKA PRAMOD
13	213	GANVIR SANGHASEN PRAMOD
14	214	GARPAL ATHARV VINOD
15	215	GHUNDIYAL HARSH RAVINDRAKUMAR
16	216	GOPANI YASH JAGDISH
17	217	GOPATHI SUPRIYA
18	219	GOVIND KADAM
19	220	HANNAMSHETTY ABHIJEET MADHAVRAO
20	221	KADBHANE ASHUTOSH GANESH
21	222	KANKATE VAISHNAVI PRITAM
22	223	KAPADNE PRADNYA KISHOR
23	224	KAWADE AKASH RAVASAHEB
24	225	KOKATE AJAY AUDUMBAR
25	227	KURHADE ABHISHEK SHYAM
26	228	LAWANDE SEJAL ROHIDAS
27	229	MAYANK RAJPUROOHIT
28	230	MEHETRE SUMIT SATISH
29	232	NIRMAL ROXSTON RICHARD
30	233	PANDIT SAYALI MADHUKAR
31	234	PRANALI MAMADAPURE



32	235	PRATIK JAGDISH DIYEWAR
33	236	RAGHAVENDRA SINGH RAHORE
34	237	SALUNKHE GAURI RAHUL
35	238	SAURAV SUMAN
36	239	SHASHWAT BHOYAR
37	240	SHARMA SHIVANI HARISH
38	241	SHARMA SHUBHAM KIRAN
39	242	SHUBHAM PANDURANG KALAMKAR
40	243	SINGH DEVESH DINESH
41	244	SIRSAT VAISHNAVI DNYANESHWAR
42	245	SWAROOP BANDU BADWE
43	246	VIKESH BHARTI GOSWAMI
44	247	WADHAI SAKSHI CHANDRAKANT
45	248	WANKHADE SANKALP SANJAY
46	249	WANKHEDE HIMANSHU DHANANJAY
47	250	YASH SOLANKE
48	251	PRATIK PATIL
49	252	VIVEK MAHAJAN
50	253	BRIJESH POKAR
51	254	PRIYA GUTTE
52	255	YASH KASHIKAR
53	256	PAYAL KAMBLE
54	257	ROHAN PATRE
55	258	RITHIK DEHURIA
56	259	SAYALI PATIL

*Pchav*  
Prof. Prajakta Khairnar  
Class Teacher

*Dr.*  
Dr. Sanjay Koli  
H.O.D. (C)  
Dept. of E. & T.C. Engineering  
Dr. D.Y. Patil School of Engg. Lohegaon



Vision: Imparting quality technical education to meet the needs of industry & society



Dr. D. Y. Patil Group of Institutions' Technical Campus

**Dr. D. Y. PATIL SCHOOL OF ENGINEERING**

Dr. D. Y. Patil Knowledge City, Charholi Bk., Via. Lohegaon, Pune - 412 105.

Department of E & TC Engineering

A.Y. 2020-21

TE E&TC-Roll Call

Sr.No.	Roll Number	Students Name
1	1	Abhijeet Kamble
2	2	Ananya Chattopadhyay
3	3	Anjali Yadav
4	4	Anshu Kumar
5	5	Anuja Raju Jadhav
6	6	Attar Rehan Rafiq
7	7	Avula Vamsikrishna Subbarayudu
8	8	Bagal Rohit Rajaram
9	9	Baisware Pratik Yogesh
10	10	Bardapurkar Samruddhi Sanjay
11	11	Bhute Priyanka Chandrakant
12	12	Chandodwala Kakshil Manish
13	13	Chavan Ravi Sudam
14	14	Chetna Satla
15	15	Dalvi Divya Ram
16	16	Daulatkar Abhishek Jaikant
17	17	Desai Siddhant Ganesh
18	18	Dhavane Divya Hanumant
19	19	Divyani Deepak Solanke
20	20	Gangavkar Dev Ninad
21	21	Giri Dhiraj Haribhau
22	22	Hargane Aditya Nilesh
23	23	Hritik Subhash Pawar
24	24	Jathore Satyam Shankar
25	25	Joshi Gaurav Gajendra
26	26	Kailas Dhanraj Chaudhari
27	27	Kajale Gauri Atul
28	28	Kamble Pratima Suresh
29	29	Kolhapure Vedshri Abhijeet
30	30	Komal Prajapati
31	31	Megha Dixit
32	32	Mukherjee Shreya Swadesh
33	33	Nambiar Akhil Balakrishnan
34	34	Namdev Kisanrao Pole
35	35	Omkar Ravindra Kharkar
36	36	Pade Advait Vijayrao



37	37	Panavkar Shubham Haridas
38	38	Patil Punam Babanrao
39	39	Patil Shubham
40	40	Pawar Rutuja Sudhir
41	41	Rahul Kumar
42	42	Rahul Kumar Pandey
43	43	Rhitik Sameer Kapoor
44	44	Sabne Ram Dattatray
45	45	Samiya Pervez
46	46	Shelke Pawan Bharat
47	47	Shinde Sanket Hindurao
48	48	Sunagar Dilipkumar Shivanand
49	49	Tiwari Glory Anand
50	50	Vaishnavi Sadaram Thote
51	51	Vishal Phad
52	52	Yash Anand
53	53	Sumit Bapusaheb Tilekar
54	54	Daulatkar Abhishek Jaikant
55	55	Ashish Kumar
56	56	Ritika Singh

Mission:

- To create center of learning through an integrated, interdisciplinary approach
- To impart employability skill among students
- To establish industry linkages

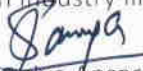
  
Dr. Samiya Ansari  
Class Teacher



  
Dr. Sanjay Koli  
HoD(E&TC)

**H.O.D.**  
**Dept. of E. & T.C. Engineering**  
Dr. D.Y. Patil School of Engg., Lohagaon





Empowerment Through Quality Technical Education  
**Dr. D. Y. Patil School of Engineering**  
Dr. D. Y. Patil Knowledge City, Charholi (Bk), Lohegaon,  
Pune – 412 105 Website: <https://dypsoe.in/>  
**Department of E & TC Engineering**

**Roll Call List**

**A. Y.: 2020-21**

**Semester: I/II**

**Class: BE E&TC**

**Division: A**

**Name of Class-Teacher: Prof. Swati S.Khawate**

Roll Number	Name of Student	Contact Details
1	AITLAWAR SALONI RAJENDRA	8308642572
2	AJAY SINGH	8884676964
3	AKASH YASHWANTRAO CHAVAN	8983735483
4	AMBUSKAR NEHA SUDHAKAR	9970012512
5	AMOL BHARATRAO ACHARYA	8379860777
6	ANSARI JAVED RAJIULLAH	8446490410
7	AWATE PRATEEK PRASHANT	8180888478
8	BADGUJAR PRATHAMESH CHARUDATTA	8830421803
9	BALVEEN SINGH SAHOTA	9730852823
10	BAMDALE RUSHIKESH ASHOK	8007849172
11	BANSODE SUKANYA DHARAMENDRA	7218217349
12	BEDARKAR SOMESH ULHAS	8446549087
13	BURSHE BALAJI TULSHEDAS	7058395791
14	CHAUDHARI NIKHIL SHIVAJI	8999561753
15	CHOURASIA PRIYANKA SANJAY	9970308398
16	DARAKHE AJAY BALASAHEB	8669330487
17	DAS SUCHISMITA SUBHASIS	9960291503
18	DEEPAK KUMAR	8825378828
19	DEVPANDEY AKASH RAJESH	7387397937
20	DHONE PRACHI RAVINDRA	8793945416
21	DHULE RUSHIKESH DNYANDEO	8378855975
22	GARAD SWAPNIL SHANKAR	7744066232
23	GAWALI MAYUR SOPAN	9823897333



24	GHORPADE NITIN YUVRAJ	9766552969
25	GHORPADE RAGHAVENDRA MARUTI	8904996899
26	HANDORE SUMEET RAVINDRA	8855057440
27	HARKAL GANESH BABASAHEB	9527773664
28	HATWAR SOPAN DHANRAJ	9404116474
29	JADHAV RATNARAJ RAVINDRA	8698797100
30	JAGTAP PAVAN CHANDRAKANT	8793065118
31	KADAM PIYUSH SATISH	8975290864
32	KADAM ROHIT SANJAY	7798279809
33	KADAM SUJIT HARISHCHANDRA	9096525701
34	KALE AKASH ANNASAHEB	9922372432
35	KHAN MOHAMMED DHANISH FIRAJ BADRUDDIN	9168593765
36	KHANDALKAR MUKUL KISHOR	8824412043
37	KURANKAR PRANAV AJAY	8806329396
38	MOHD HAMID	9766912252
39	MORE OMKAR GOPAL	7517586780
40	MORE SHUBHAM SUBHASH	8446425955
41	NAIVANGUNE KRISHNAKANT DHANANJAY	9766744500
42	NISHAD PRADEEP KHAROTE	8237400132
43	PRABAL PANDEY	9325457918
44	RAJPATHAK NIRAJ SATISH	7028714160
45	RANDHAVE VAIBHAV TANAJI	9834481173
46	RITIKA JHA	9518925572
47	ROHINI BHAUSO MHASKE	8605831959
48	SAMEEKSHA SINGH	8390189716
49	SHAIKH ASIM SHABBIR	8600006464
50	SHELAR SHRIDHAR NARAYAN	9970590218
51	SHIVANGI AGNIHOTRI	7999658154
52	SWATI JHA	9284302718
53	TANMAY SANJAY KADAM	8378822459
54	TAPKIR PRATIK TANAJI	9049942525
55	THOMBRE VISHALKUMAR BHAGUJI	7887986511
56	THOSAR AASHUTOSH VIJAYKUMAR	8623811492



57	VAVILASHETTY VENKAT SAI KUMAR SHRINIVAS	9370534381
58	WAGHMARE VAIBHAV SHARAD	9850052372
59	YADAV AVINASH BABURAM	8149332254
60	MOHIT SANJAY SHARMA	9420674315
61	Komal Yuvraj Udmale	9096525701
63	Sayali Mandekar	8999508631
64	Kamble Dhiraj Pandurang	9762626669
65	Barge Aakash Dilip	7040975830
66	Ram Dhas	9325315398

*Swati S. Khawate*

Signature of Class Teacher

Name: Prof. Swati S. Khawate



*[Signature]*

Signature of HoD

**H.O.D.**  
Dept. of E. & T.C. Engineering  
Dr. D.Y. Patil School of Engg., Lohegaon



Dr. D. Y. Patil Technical Campus

# **Dr. D. Y. Patil School of Engineering**

Dr. D. Y. Patil Knowledge City, Charholi (Bk), Lohegaon, Pune – 412 105

22) Work Distribution Chart.



# Department of Mechanical Engineering

22

## Staff Responsibility AY 2021-22

Sr. No.	Name of the Employee	NAAC-Criteria	Committee Form (Team Form) AY 2021-22 (Sem-I)	Class Teacher & Mentor	Lab Incharge	Other
1	Rohit Nagesh Garad	1 to 7	HOD	-	-	
2	Dr. Farook Bashir Sayyad	-	Dean Academics	-	-	
3	Dr. Dilleep S. More	-	EDC (college level) - Coordinator	-	-	
4	Santosh Baburao Jadhav	1 to 7	ACTE/DTE/IQAC - Coordinator TW/PR/OR - Coordinator	-	-	
5	Prashant Gurushtappa Karajagi	-	CEO	-	-	
6	Amol Nanaji Patil	6	PG - Coordinator V-Lab - Coordinator	H2 Mentor	-	
7	Amol Baburao Gaikwad	3	NBA- CO-PO mapping & Attainment - Coordinator Maintenance - Coordinator R & D - Co-Coordinator MoM - Coordinator	B1 Mentor	PG Lab	
8	Yogesh Shankarrao Danekar	7	TE Seminar - Coordinator Maintenance - Co-Coordinator	G3 Mentor	CAD/CAM Lab	
9	Ghule Vikram M	4	SAE - Coordinator MESA - Coordinator	G2 Mentor	TOM Lab	



			S.E. Online Exam - Co- Coordinator			
			Feedback Analysis - Coordinator			
10	Parag Bapu Marathe	3	IPR - Coordinator	BE G Class Teacher 11 Mentor	MQC Lab	
			R & D -Co-Coordinator			
			ERP/LMS -Co-Coordinator			
			T & P - Coordinator			
11	Parash Pravin Khairnar	1	Alumni Meet - Coordinator	G1 Mentor	H & P Lab	
			BE Project - Coordinator	TE D Class Teacher D3 Mentor		
12	Yogesh S. Gandai	2	Cell for Higher Studies & competitive Exam - Co-Coordinator			
			Time Table - Coordinator			
			BE Project - Co-Coordinator	H1 Mentor	DOM Lab	
13	Umaji Kolekar	6	TW/PR/OR - Co-Coordinator			
			NSS - Coordinator			
			Sports & Cultural - Coordinator	B2 & 12 Mentor	MTX Lab	
14	Sachin S. Jadhav	5	SAE - Co-Coordinator			
			ROBO Club - Co-Coordinator			
			V-Lab - Co-Coordinator			
			Sports & Cultural - Co-Coordinator			
15	Tejaswini Suhask Kulkarni	2	In Sem Exam - Co-Coordinator			



16	Pooja Nawathe	5	Guest Lecture - Co-Coordinator	BE I Class Teacher I3 Mentor	SD Lab	
			T & P - Co-Coordinator			
17	Jagruti C. Nimgulkar	2	Time Table - Co-Coordinator	BE H Class Teacher H3 Mentor	RAC Lab	
			Feedback Analysis - Co-Coordinator			
18	Kunal Shrirampakash Marathe	7	ROBO Club - Coordinator	D2 Mentor		
			Result Analysis - Coordinator			
			MESA - Co-Coordinator			
19	Dr. Mohd. Imran Ansari	3	R & D - Coordinator	TE E Class Teacher E3 Mentor	Theromodyanic Lab	
			IPR - Co-Coordinator			
20	Vinod Gopal Patil	2	Website Updating, ERP/LMS - Coordinator	E2 Mentor		
			MESA - Co-Coordinator			
21	Sandeep Bhaskar	1	EDC, IIRC - Coordinator	E1 Mentor		
22	Dipak D. Shekhe	5	Industrial Visit, Dept. Lib. & NPTEL & In Sem Exam - Coordinator	SE -A Class Teacher D1 Mentor	AT Lab	
23	Amit Shinde	5	S.E. Online Exam, Cell for Higher Studies & competitive Exam - Coordinator	SE -B Class Teacher B3 - Mentor	EMM Lab	
24	Kundan S. Kolambe	4	EDC, IIRC - Co-Coordinator		HT Lab	
25	Nitin More	1	All Labs - Coordinator TE Seminar, Result Analysis - Co-Coordinator			
26	Himani Kadam	3	Guest Lecture - Coordinator R & D, In Sem Exam - Co-Coordinator		FM Lab	
27	Anil Bavche	2	AICTE/DTE/ IQAC, NBA- CO-PO Mapping & Attainment - Co-Coordinator			
28	Awes Ansari	-	FE		EG lab	
29	Vinod Tripude	-	FE		SME Lab	

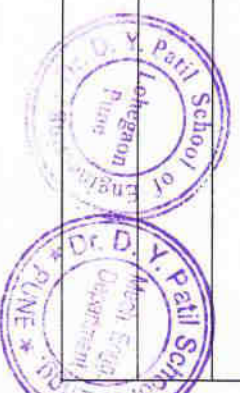



Dr. D Y Patil Technical Campus  
**Dr. D. Y. Patil School of Engineering**  
 Dr. D. Y. Patil Knowledge City, Charholi Bk, Via Lohegaon, Pune – 412105

Date- 17/08/2020

### COMP DEPT NAAC- COMMITEE

All the faculty members need to work for the NAAC (National Assessment and Accreditation Council ) related work. The following are the responsibilities that need to be carried out by the faculty members. The Names in bold letters are the Team Heads.

Sr. No.	NAAC Team Members	NAAC Work	Mark/Weightage
1.	<b>Prof. Yogesh Mali</b> Prof.Pooja Shinde Prof.Komal Jakotiya Ms. Snehal Patil	CRITERION 1: Curricular Aspects	100
2.	<b>Prof. Jayshree Chaudhari</b> Prof. Pallavi Shimpi Prof.Poonam Bhogade Prof.Swati Kadu Mr. Nitin Kanade	CRITERION 2: Teaching-Learning and Evaluation	350
3.	<b>Dr. Sunil Rathod</b> Prof. Prashant Mandale Mr. Vishal Patil	CRITERION 3: Research, Innovations and Extension	150
4.	<b>Prof. Ashwini Pandagale</b> Prof. Vishal Borate Ms. Priyanka Thorat	CRITERION 4: Infrastructure And Learning Resources	100
5.	<b>Prof. Ajita Mahapadi</b> Prof.Amruta Chitari Mr. Omkar Patil	CRITERION 5: Student Support and Progression	100
6.	<b>Prof. Monika Dangore</b> Prof. Chaitanya Bhosale Mr.Nikhil Rahtwal	CRITERION 6: Governance, Leadership and Management	100
7.	<b>Prof. Nilesh Mali</b> Prof. Nilesh Pinjarkar Mr. Vishal Patil	CRITERION 7: Institutional Values and Best Practices	100

In case of any doubt related NAAC work, then feel free to contact the undersigned.

NAAC Comp Dept  
 (Coordinator)  
 Prof.Monika Dangore



HOD  
 Computer Engineering  
 Dr. Pankaj Agarkar



Head of the Department  
 Department of Computer Engineering  
 Dr. D. Y. Patil School of Engineering  
 Dr. D. Y. Patil Technical Campus  
 Via Lohegaon, Charholi Bk., Pune-412 105



Dr. D. Y. Patil Technical Campus

## Dr. D.Y. Patil School of Engineering

Department of Electronics & Telecommunication Engineering

### Portfolio Distribution

Date:18/01/2020

A.Y. 2020-21 Sem-II

Sr. No	Name of the staff	Portfolio
1	Dr. Rashmi Mahajan	<ul style="list-style-type: none"><li>• PG coordinator</li><li>• Department Academic Coordinator</li><li>• Department IQAC and NAAC coordinator</li><li>• Criteria VII</li></ul>
2	Dr. Saniya Ansari	<ul style="list-style-type: none"><li>• Exam Coordinator</li></ul>
3	Prof. Riyaj Kazi	<ul style="list-style-type: none"><li>• Criteria VI (Department)</li><li>• Class Teacher-TE</li></ul>
4	Prof. Nishikant Surwadè	<ul style="list-style-type: none"><li>• EDC and IPR cell</li><li>• Project Coordinator</li><li>• Criteria II (Department)</li></ul>
5	Prof. Swati Khawate	<ul style="list-style-type: none"><li>• Class Teacher-BE</li><li>• Time Table Incharge</li><li>• Criteria-III (department)</li></ul>
6	Prof. Prajкта Khairnar	<ul style="list-style-type: none"><li>• Event coordinator</li><li>• Class Teacher-<del>TE</del> S.E.</li><li>• Criteria I (department)</li></ul>
8	Prof. Gaurav Tiwari	<ul style="list-style-type: none"><li>• Criteria-IV (department)</li></ul>
9	Prof. Ashwini Bagde	<ul style="list-style-type: none"><li>• T&amp;P coordinator</li><li>• CR-V (department)</li></ul>

  
Dr. Sanjay Koli  
HoD (E&TC)



# DUTY CHART 2<sup>nd</sup> TERM AY 2020-21

## DEPARTMENT OF CIVIL ENGINEERING

**HOD (SMK)**

Academic  
I/C – AAI, AVN

R&D & Projects  
I/C – RCK, UAS

Student Activity  
I/C – UAS + UAK

**PLANNING MONITORING & PROGRESS (AAI)**

- \*CLASS TEACHEAR S.E (UAS)
- M-I UAS
- M-II SPB
- M-III AVN
- \*CLASS TEACHEAR T.E (U/AK)
- M-I UAK
- M-II AVN
- M-III AAI
- \*CLASS TEACHEAR B.E (PS)
- M-I PS
- M-II RCK
- M-III UAS
- \*PURCHASE & STATIONARY (RCK)
- \*LEAVE RECORD (UH & Resp. Class teacher)
- \*COMPUTER PERIPHERAL & OTHER WORKS (RK)
- \*ERP (SPB & MDD)
- \*WEBSITE UPDATION (SPB&MDD)
- \*DOCUMENT MAINTENANCE (RCK, AVN & RK)
- \*STUDENTS ATTENDANCE (Class Teachers)
- \*PARENTS TEACHER MEET (PS & AAI)
- \*COMPETITIVE EXAMS PREPARATION (AVN)

**EXAM (UAK & SPB)**

- \*THEORY EXAM
- \*ONLINE EXAM
- \*IN SEM EXAM
- \*OR/P/R EXAM
- \*MOC EXAM
- \*CLASS TEST
- \*MY EXAMO
- \*COUNSELLING

**INSPECTION/ VISITS (SPB, RCK& SMK)**

- IQAC (SPB)
- NAAC(RCK)
- NBA(RCK)
- LIC(RCK)
- AICTE(RCK)

**\*SEMINAR (AAI)**

- \*WORKSHOP (PS & RCK)
- \*T&P (PS)
- \*BE PROJECT (PS)

**(UAS + F-1)**

- \*INDUSTRIAL VISIT
- \*GUEST LECTURE
- \*LAB DEVELOPMENT (Lab In charges + RCK)

**\*CESA ACTIVITY – (UAK) (STAFF coordinator)**

- \*TECH FEST (UAS)
- \*CULTURAL ACTIVITY (AVN, PS, RCK)
- \*SPORTS (F-1)
- \*DEPARTMENTAL LIBRARY (UAS, RK)

SMK Prof. Sanjay Karodpati.  
RCK Prof.R.C. Kardare  
SPB Prof. S. P. Bijwe

UAK Prof.U.A. Kakde.  
UAS Prof.Uzma Shaikh  
PG Prof. Prasad Gayake

Prof Akanksha Ingole  
Academic I/C

AVN Prof. A. V. Nemade  
AAI Prof. A. A. Ingole

PS Prof. Pragya Sharma  
F-1 New Faculty

Prof. R.C. Kardare  
Department Coordinator



KDG Mr. K.D. Gaikwad  
MDJ Mr. M.D. Jadhav  
USH Mrs. U.S. Hodgar  
RK Mrs. Ragini Kelkar

H.O.D.  
Dr. D. Y. Patil School of Engrg. Lohegaon

FF

	<p>Dr. D. Y. Patil Technical Campus  <b>Dr. D. Y. Patil School of Engineering</b>          Dr. D. Y. Patil Knowledge City, Charholi Bk., Via. Lohegaon, Pune - 412 105.</p>
---	---

Date: 06/02/2021

Department of Engineering Sciences (FE)

**Office Order**

Portfolio Distribution (Semester-I, 2020-21)

S. N.	Faculty Name	Assigned Portfolio
1	Ms. R. S. Gadgil	1. Academic Coordinator 2. BEE Lab In charge
2	Ms. Soma Cyriac	1. Coordinator- Continuous Assessment 2. Coordinator- Discipline Committee
3	Mr. Amit Uphad	1. Sub Coordinator- Class Tests / Exams 2. EP Lab In charge
4	Dr. Shobha Rupnar	1. Coordinator -Term Work 2. Coordinator – FESA
5	Dr. Niraj Jadhav	1. Coordinator – NAAC /IQAC Documentation 2. EC Lab In Charge
6	Dr. Rahul Katkade	1. Coordinator- Time table 2. Coordinator- Result analysis
7	Mr. Bhagwat Gidhad	1. Coordinator- EDC, R&D, III 2. Coordinator- P. E. and Sports
8	Ms. Sayali Mane	1. Coordinator – PBL 2. Class Teacher- Div C
9	Mr. Vinod Tirpude	1. Coordinator – Class Tests / Exams 2. SME/ EG Lab In charge
10	Mr. Awes Ansari	1. Class Teacher – Div B 2. Coordinator –Soft Skills, Industrial Visits
11	Mr. Prashant Sagare	1. Coordinator – LMS and MS Teams, ERP 2. Class Teacher – Div A
12	Mr. Prasad Gayake	1. Class Teacher- Div D 2. EM Lab Incharge

Note: Mr. Tejpal Pardeshi from DYP SOET will share BEE workload of Div B.

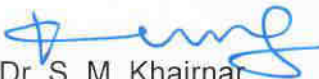
  
 Dr. S. M. Khairnar  
 Head of Department

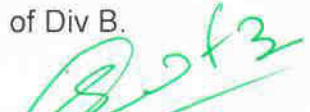
  
 Dr. Ashok Kasnale  
 Principal- SoE



1.1.22



Dr. D. Y. Patil Group of Institutions' Technical Campus  
**Dr. D. Y. PATIL SCHOOL OF ENGINEERING**  
 Dr. D. Y. Patil Knowledge City, Charholi Bk., Via. Lohegaon, Pune - 412 105.  
 Department of Computer Engineering

Date: 11.01.2021

**Faculty Portfolio Distribution**

AY 2020 - 2021 ( Sem - I, II)

**With effective from: 11/01/2021**

Sc No.	Portfolio Name	Name of Faculty
1	UG Class Teacher & Departmental Registration for Students, attendance display after 15 days, handles all types Samaj Kalyan issues, fee related issue, scholarship issues. Coordinate with office staff.	SE A-Prof. Ashwini Pandagale
		SEB- Prof. Pooja Shinde
		TE A- Prof. Amruta Chitari
		TE B- Prof. Chaitanya Bhosale
		BE A- Prof. Niyamat Ujloomwale
		BEB- Prof. Pallavi Shimpi
2	GFM Coordinator	Prof. Prashant Mandale
3	PG Coordinator	Dr. Sunil Rathod, Supporting staff: Mr. Vishal Patil
4	Discipline Coordinator for dept. Checking daily ID cards, Uniform, You also visit to Canteen, Campus for purpose of improve students attendance.	Prof. Prashant Mandale
		all Class Teachers respective division Mr. Niteen Kanade, Priyanka Thorat Mr. Vishal Patil, Nikhil Rahtwal
5	Time Table Coordinator	Prof. Jayshree Chaudhari, Ms. Snehal Patil
6	ERP Coordinator	Prof. Prashant Sagare
7	UG Project Coordinator	Prof. Monika Dangore
8	TE Seminar Coordinator	Dr. Sunil Rathod
9	Departmental Training & Placement/Career Development Coordinator.	Prof. Yogesh Mali
10	SPPU (Insem, Endsem) and Unit. Test Exam Coordinator	Prof. Vishal Borate
11	UG/PG SPPU (Pr/Or/Tw) Exam Coordinator	Prof. Amruta Chitari Prof. Vandana Chavan
12	SPPU Online Exam Coordinator	Prof. Monika Dangore Prof. Pooja Shinde
13	Foreign Language Training/Audit Course Coordinator	Prof. Chaitanya Bhosale





14	Departmental Research (R / D) I/C	Dr. Sunil Rathod
15	I)NAAC/NBA Coordinator II)IQAC Coordinator for NAAC/NBA	Prof. Niyamat Ujloomwale Prof. Monika Dangore
16	Guest Lecturer Coordinator , MOU,HODminutes of meeting	Prof.Prashant Mandale
17	ACE Coordinator and monthly report coordinator	Prof.Pooja Shinde (Incharge) Prof.Yogesh Mali (Accounting) Prof.Chaintanya Bhosale (Members) Prof.Prashant Mandale (Members) and all non-teaching staff
18	Alumni Coordinator	Prof.Monika Dangore
19	E-Magazine Coordinator	Prof.Ashwini Pandagale
20	Departmental Library In charge & Record Keeping Coordinator	Prof. Jayashree Chaudhari Ms. Snehal Patil
21	Stationary In charge	Mr.Vishal Patil
22	Student Grievance Cell Coordinator	Dr.Sunil Rathod, Prof.Jayshree Chaudhari
23	File Maintenance & Documentation	Miss.Priyanka Thorat(Dept office I/C) Mr.Niteen Kanade Mr.Vishal Patil Ms.Snehal Patil Mr.Omkar Patil
24	SPPU Theory exam	Prof.Yogesh Mali and Chaintanya Bhosale ( Asst. to Sr.Sup) Mr.Vishal Patil Ms.Snehal Patil Mr.Omkar Patil Mr.Niteen Kanade
25	ISO/IIIC/EDC/Website	Prof.Vishal Borate

**Note:**

All Coordinators Maintain all records of their portfolio and update in our dept. office time to time ( Ms.Priyanka and Ms Snehal )

**Dr Pankaj Agarkar**  
**HOD Computer Dept**

**Head of the Department**  
Department of Computer Engineering  
Dr. D. Y. Patil School of Engineering  
Dr. D. Y. Patil Technical Campus  
Via Lohegaon, Chancholi Ek., Pune-412 105.





Dr. D. Y. Patil Group of Institution's Technical Campus  
**Dr. D. Y. Patil School of Engineering**  
Dr. D. Y. Patil Knowledge City, Charoli Bk., Via. Lohegaon, Pune - 412 105.

**CIVIL ENGINEERING DEPARTMENT**

Date: 20/12/2019

All the faculty and Staff members are instructed to go through the content of the circular mentioned below showing allotment of duties and Responsibilities to each faculty and Staff members in order to have smooth functioning of the various activities in the department. This is to be read in reference to the Organizational chart of the department. Additional responsibilities other than this are also attached separately for noting and compliance.

S.N.	Item	Activities	In-Charge
1	Lab In Charges	Maintenance Of Lab Procurement Of Equipment, Requirement, Budget DSR Maintenance	ENV-RCK
			SUR-SPB
			GTE- SMK/F-1
			FM-UAS
			GEO.-PS
			TRE-PS
			TOM-UAK
			MECH-PG
2	Class Teacher S. E. Civil T. E. Civil B. E. Civil	i) Finalizing subject teacher ii) Get prepared Teaching Plan of each subject based on past experiences iii) Student's Registration iv) Roll no allotment and Batch formation (Subject to fees payment) v) Preparation of Roll call list and hand over to subject Teacher and Academic Coordinator. vi) Monitoring of Lectures/Practical and Daily load adjustment as per time table. vii) Compilation of Attendance Syllabus Covered. viii) Maintenance Of Class Records ix) Preparation Of Defaulters List	SE-UAS
			TE-UAK
			BE-PS
3	Specific duties of Class Teachers	S.E.: i) To get prepared extended teaching Plan for D2D students from all SE teachers and get it implemented. ii) Establish rapport with D2D students and help them get familiarized with new environment and increase their comfort level in the class room. iii) Get question bank for online examination and train D2D students for undergoing online examination. iv) Confirmation of filling up of online examination form by all students three days prior to examination. v) Consult Departmental Examination	SE-UAS



Dr. D. Y. Patil Group of Institution's Technical Campus  
**Dr. D. Y. Patil School of Engineering**  
Dr. D. Y. Patil Knowledge City, Charoli Bk., Via. Lohegaon, Pune - 412 105.

		Coordinator for preparation of online Examination. vi) Maintaining record of all above mentioned activities in the form of minutes of the meeting held regularly with concerned faculty members.	
		<b>T.E.:</b> i) Consult Departmental Examination Coordinator for preparation of online Exam. ii) Record keeping in the form of minutes of meeting held from time to time.	<b>TE-UAK</b>
		<b>B.E.:</b> i) Consult Departmental Examination Coordinator for preparation of online Exam. ii) To get informed about progress of the work done by all students. iii) Record keeping in the form of minutes of meeting held from time to time.	<b>BE-PS</b>
4	Project /Elective	i) Formation Of Groups & Keeping Records Taking Feedback About Progress Of Work Selection of Elective.	<b>PS &amp; RCK</b>
5	Extra/Curricular Activities	Keeping The Records Of Students & Faculty All Related Works	<b>UAS</b>
6	Academic Monitoring	Daily Report Preparation Submitting It In Office	<b>AAI &amp; RK</b>
7	Parent Teacher Meet	i) Scheduling The Event & Arrangement Of Meet once In A Semester ii) Informing The Parents iii) Keeping The Register & Taking Feedback	<b>AAI &amp; UH</b>
8	Term Work Marks	i) Moderation Of Marks ii) Term Work Order Preparation iii) Filling Of Marks And Printouts Submitting	<b>UAK &amp; SPB</b>
9	Time Table	i) Load Distribution ii) Class Time Table iii) Individual Time Table	<b>AAI</b>
10	Training & Placement	i) Meeting With H.R. Managers Of Various Civil Engineering Companies ii) Personality Development Program for Students iii) All The Activities Related To Training & Placement Work.	<b>PS + F-1</b>
11	Practical & Oral Exams	i) Preparation Of Tentative Schedule Of The Exam, Procurement Of Stationery ii) Co-Coordinating The Exam	<b>UAK + SPB</b>



Dr. D. Y. Patil Group of Institution's Technical Campus  
**Dr. D. Y. Patil School of Engineering**  
Dr. D. Y. Patil Knowledge City, Charoli Bk., Via. Lohegaon, Pune - 412 105.

12	Unit Test	i) Collection of Question Bank of each subject ii) Preparation Of Time Table iii) Printing & Photocopying Of Test Papers. iv) Display Of Test Marks	SPB + UAK + RK + MRJ
13	Budget	Preparation & Compilation Of Budget	KG, RCK, HOD
14	Purchase & Procurement	Follow Up With Account Section & Central Purchase Committee	Lab I/C & RCK
15	Maintenance	Departmental Maintenance (Electrical, Civil, Furniture etc.)	Lab I/C & AVN
16	Procurement Of Stationery, Other Materials.	Filling Indent As Per Requirement Maintaining The Records of Material Procured.	AVN + KG
17	R & D Cell	All The Related Work	RCK & UAS
18	Recruitment Of Faculties	All The Related Work With Interview.	HOD & RCK
19	N.B.A .and NAAC	All Related Work	SMK, RCK + Criteria Coordinators
20	Alumni	i) Keeping Record Of Alumni Students ii) Updating Information	PS + UH
21	Minutes Of Meetings	i) Deciding The Venue ii) Writing Minutes Of Meetings iii) Taking Signature On Minutes	AAI
22	ERP/Web Site Updating	All The Related Work To Web Site	SPB & MDJ
23	Office Filing	Maintaining All The Files Including Old Notices And Circulars From Notice Board	AVN & RK
24	Departmental Library.	Collection Of Books Keeping Record Of The Books Issue And Return Of The Books	UAS & RK
25	Monthly Performance Report	i) Updating the Monthly Performance Of Faculty & Departmental Activities.	AAI & RK
26	Notice Board /Wall Magazine	i) Displaying Innovations In Construction And Technology ii) Motivating The Students For Collection Of the Various Material iii) Removing after Two Weeks & Filling	UAS & AAI
27	Guest Lectures	i) Planning For The Guest Lectures In Advance arrangement For The Transport ii) Arrangements In Seminar Hall /Class Room	UAS + FI



Dr. D. Y. Patil Group of Institution's Technical Campus  
**Dr. D. Y. Patil School of Engineering**  
Dr. D. Y. Patil Knowledge City, Charoli Bk., Via. Lohegaon, Pune -412 105.

		with Teaching Heads. iii) Preparation And Sending Reports	
28	Events Anchoring	Anchoring For The Events	AVN, PS , RCK
29	Presentation	Preparation Of Presentation During Committee Visits Of Meetings.	UAS, RCK, SMK & MDJ
30	Industry Institute Interaction	Preparation of MOU with Industries, Internship for students, site visit & lectures/ courses.	PS & RCK
31	IQAC	Preparation of Performa and returns related to ISO and IQAC	SPB, SMK
32	Seating arrangement	RDK- Cabin 1, AVN-Cabin 2, RCK-Cabin 3, AAI-Cabin 4, UAK- TOM Lab, SPB- Survey store, UAS – FM Lab. AG – Mechanics Lab. KDG- TOM Lab, MDJ- FM Lab, UH– Survey Lab RK- ENV lab	
33	Labs given to lab Assistant	KDG– TOM + Geotech Lab, MDJ – FM + Comp Lab, UH- Survey + TRE and RK- ENV and Geology	

The Initials mentioned under In charge column are belonging to respective faculty members.

**Initials Used**

RCK – Prof. R C Katdare  
AVN– Prof. A V Nemade  
UAS– Prof. Uzma A Shaikh  
PS- Prof. Pragya Sharma  
MDJ– Mr. Maruti Jadhav  
RK- Raghini Kelkar

RDK – Prof. R D Koshti  
SPB– Prof. S B Bijwe  
AG- Prof. Aradhana Ganvir

KDG– Mr. Kiran D Gaikwad  
SB- Mr. Santosh Bhosale

UAK– Prof. U A Kakade  
AAI- Aakanksha Ingle  
PG- Prof. P Gayake

UH– Mrs. Usha Hodgar

  
Prof. A.A. Ingale  
Academic I/C

  
Prof. R.C. Katdare  
Department Coordinator

  
Prof. S.M. Karodpati  
HOD

**H.O.D.**  
Department of Civil Engineering  
Dr. D. Y. Patil School of Engg. Lohegaon,

